

ITEM	DESCRIPTION	No REQ'D	MATERIAL	2"	2 1/2"	3"	4"	6"	8"	10"	12"
R-1	HANDWHEEL NUT	1	BRONZE ASTM B584 C87850 or C87610								
R-2	HANDWHEEL	1	DUCTILE IRON ASTM A536 70-50-5								
R-3	THRUST WASHER	UPPER	BRONZE ASTM B36 2 1/2" = DELRIN/VELCON	0	0	1	1	1	1	1	1
		LOWER		1	1	1	1	1	1	1	1
R-4N	ANTI FRICTION BEARING	1	NYLATRON SIZES 3 - 12"								
R-5	YOKE NUT	1	BRONZE ASTM B584 C86700								
R-6	HEX. HEAD BOLTS		ZINC PLATED STEEL or STAINLESS STEEL	(4) 1/2-13x2	(4) 1/2-13x2	(4) 1/2-13x2	(4) 1/2-13x1.75	(8) 5/8-13x2.25	(8) 5/8-13x2.25	(8) 5/8-11-2.75	(8) 5/8-11-2.75
	HEX. NUTS		ZINC PLATED STEEL OR STAINLESS STEEL	(4) 1/2	(4) 1/2	(4) 1/2	(4) 1/2	(4) 5/8	(8) 1/2	(8) 1/2	(8) 1/2
R-7	COVER	1	KS-RW, KS-RWHP, & KS-FWD	DUCTILE IRON ASTM A536 GRADE 70-50-5							
			KS-FW	CAST IRON ASTM A126 CLASS B							
R-8	HEX. NUTS	2	BRASS	1/2 HVY HEX	1/2 HVY HEX	1/2 HVY HEX	1/2 HVY HEX	1/2 HVY HEX	1/2 HVY HEX	5/8 HVY HEX	5/8 HVY HEX
	SQ. HEAD BOLTS	2	ZINC PLATED STEEL OR STAINLESS STEEL	1/2-13x2.50	1/2-13x2.50	1/2-13x2.75	1/2-13x2.75	1/2-13x2.75	1/2-13x2.75	5/8-11x3.5	5/8-11x3.5
R-10	GLAND	1	DUCTILE IRON ASTM A536 (70-50-5)								
R-11	PACKING		SQ. BRAIDED NON-ASBESTOS	(4) 5/16SQx3-7/8	(3) 5/16SQx3-7/8	(3) 3/8 SQ x 5	(3) 3/8 SQ x 5	(3) 3/8SQ x 5-5/8	(3) 3/8 SQ x 6	(3) 1/2 SQ x 6.5	(3) 1/2 SQ x 6.5
R-12	"O" RING	1	BUNA-N	DASH 2-347	DASH 2-425	DASH 2-427	DASH 2-437	DASH 2-445	DASH 2-447	DASH 2-452	DASH 2-455
R-13	"O" RING (STEM ASSY) <sup>(1) part of stem assy</sup>		BUNA-N	DASH 2-316	DASH 2-316	DASH 2-320	DASH 2-320	DASH 2-322	DASH 2-324	DASH 2-325	DASH 2-325
R-14	STEM ASSEMBLY	1	BRASS ASTM B371 C69300/ASTM B806 C95400/95500 OR 304 STAINLESS STEEL								
R-15	EPDM ENCAPSULATED WEDGE	1	DUCTILE IRON ASTM A536 GRADE 70-50-5								
R-16	FLANGED BODY	ALL	KS-RW	DUCTILE IRON ASTM A536 GRADE 70-50-5							
	SCREWED BODY	KS-FW KS-FWD	KS-RWHP								
	GRVxGRV & GRVxFLG	KS-RW	KS-FWD								
		KS-RWHP	KS-FW								

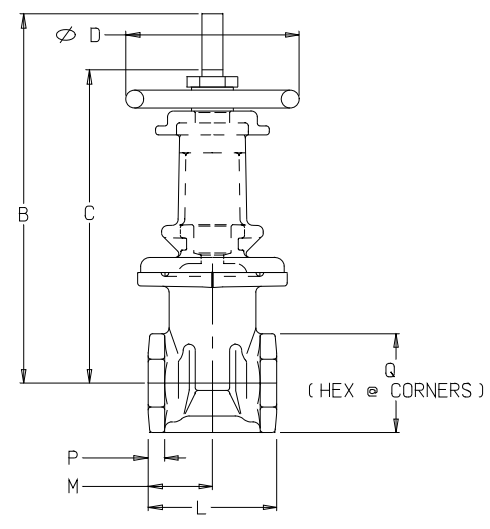
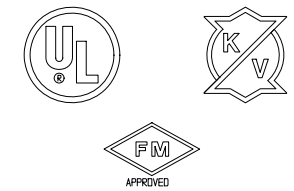
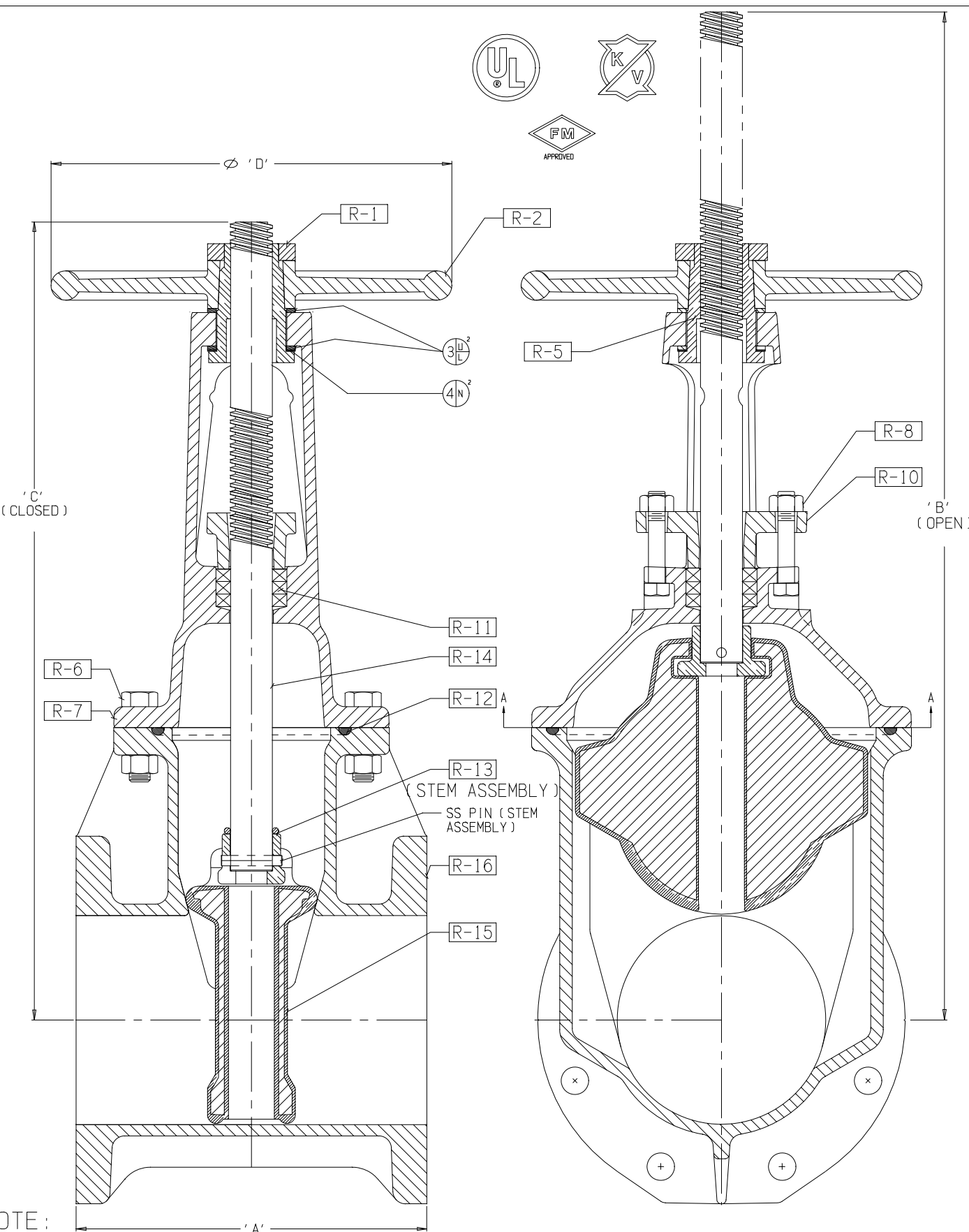

THD X THD

SPECIFIC THD X THD DIMENSIONS

VALVE SIZE	Model	L	M	P	Q	-	-
2	KS-FW	5.38	2.69	0.69	4.13	-	-
2 1/2	KS-FW	7.12	3.56	1.06	5.18	-	-
3	KS-FW	7.26	3.63	1.08	5.63	-	-

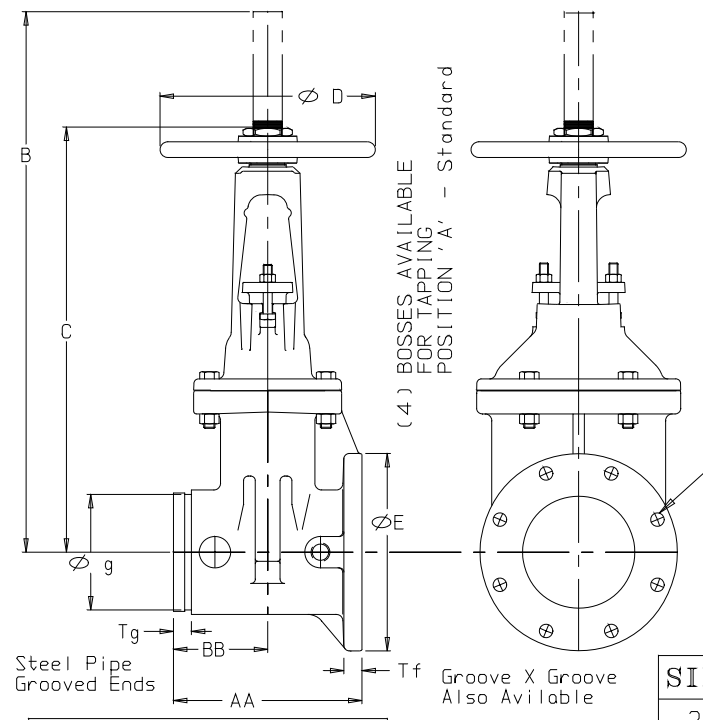

125 LB. STD. DRILLING  
B-16.1 FLANGED END  
A-21.11 SMJ END

COMMON DIMENSIONS - ALL FLANGE END VALVES

SIZE	Model(s)	A	B	C	D	No. TURNS to OPEN
2"	KS-FW, KS-FWHP	7"	15 7/16"	13 3/32"	7 1/4"	6.5
2 1/2"	KS-FW, KS-FWHP	7 1/2"	16 3/8"	13 7/8"	7 1/4"	8
3"	KS-FW, KS-FWHP	8"	18 7/8"	15 5/8"	10"	10
4"	KS-FW, KS-RW, AND KS-RWHP	9"	22 3/4"	18 1/4"	10"	13 1/2
6"		10 1/2"	30 1/8"	23 3/4"	12"	19 1/2
8"		11 1/2"	37 3/4"	29 1/4"	14"	25 1/2
10"		13"	45 3/4"	35 3/8"	18"	31 1/2
12"		14"	53 1/8"	40 5/8"	18"	37 3/4

SPECIFIC GRV X FLG DIMENSIONS

VALVE SIZE	Model	AA	BB	Tg	Ø g	E	Tf
2 1/2	KS-RW	7 1/2	3 3/4	.92	2.68	7	11/16
3	KS-RW	8	4	.92	3.31	7 1/2	3/4
4	KS-RW	9	4 1/2	1	4.31	9	15/16
6	KS-RW	10 1/2	5 1/4	1	6.43	11	1 1/8
8	KS-RW	11 1/2	5 3/4	1.18	8.40	13 1/2	1 1/8
10	KS-RW	13	6 1/2	1.25	10 1/2	16	1 3/16

NO.	Date	ECN	REVISION
5	2/15	-	ADDED MODELS KS-FWHP & KS-RWHP
-	6/13	-	ADDED 304 STAINLESS STEEL STEM
4	4/11	-	UPDATED WEDGE MATERIAL TO MATCH UPGRADE
3	10/09	-	ADDED SPECIAL DI MATERIAL FOR KS-FW
2	08/04	-	Added 2" Grv x Grv and Flg x Flg to assembly

NOTE: CONFORMS TO DIMENSIONAL, MATERIAL & TEST REQUIREMENTS  
AWWA C515 - MODELS 'KS-RW' & 'KS-RWHP'  
AWWA C509 - MODELS 'KS-FW' & 'KS-FWHP'

\* HALF SCALE OF A 6" FLG X FLG VALVE

KENNEDY VALVE ELMIRA, N.Y. 14901	
2" THRU 12" MODEL - KS-FW, KS-RW, KS-FWHP, & KS-RWHP OS&Y ASSEMBLY	
FILE PATH: DRAFTGATE	DWG NO. 81336
Drawn by: BES	Revision 05
ISSUED: 10JAN2000	