

SECTION A-A FOR  
HANDWHEEL OPERATORS  
POSITION INDICATOR

ITEM #	DESCRIPTION	MATERIAL
1	HOUSING OPERATOR	CAST IRON, A-126, CLASS B
2	COVER, HOUSING	CAST IRON, A-126, CLASS B
3	CAP, THRUST	CAST IRON, A-126, CLASS B
4	AS REQUIRED	CAST IRON, A-126, CLASS B
5	LEVER	DUCTILE IRON, A-536, GRADE 80-45-06
6	CROSSHEAD	STEEL, CDS AISI 12L14
7	SHAFT, INPUT	STEEL, CDS AISI 12L14
8	"O" RING	BUNA-N
9	PLUG, EXPANSION	BRASS COMM.
10	GASKET, COVER	LOCTITE MASTER GASKET
11	SHAFT COLLAR	STEEL, CDS AISI 12L14
12	INPUT SHAFT PIN	STEEL, COMM.
13	BOLT, HEX HEAD (AWWA NUT)	STEEL, ASTM A-307, ELECTRO ZINC PLT.
14	BOLT, HEX HEAD (COVER)	STEEL, ASTM A-307, ELECTRO ZINC PLT.
15	INDICATOR	CAST IRON, A-126, CLASS B
16	NUT, HEX	STEEL, ASTM A-563, ELECTRO ZINC PLT.
17	"O" RING	BUNA-N
18	PIN, INDICATOR	STEEL, COMM.
19	BUSHING	NYLON (MOLY-DISULFIDE FILLED)
20	KEY	STEEL, COMM.

M&H VALVE COMPANY  
ANNISTON, ALABAMA  
A DIVISION OF MCWANE INC.

DWN: TRIJ  
DATE: 8/24/11  
DWG. NO.  
BFV-OP-1

65, 150 & 250  
MANUAL OPERATOR  
SUB-ASSEMBLY / MATERIAL LIST

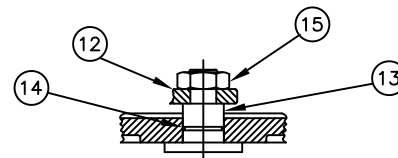
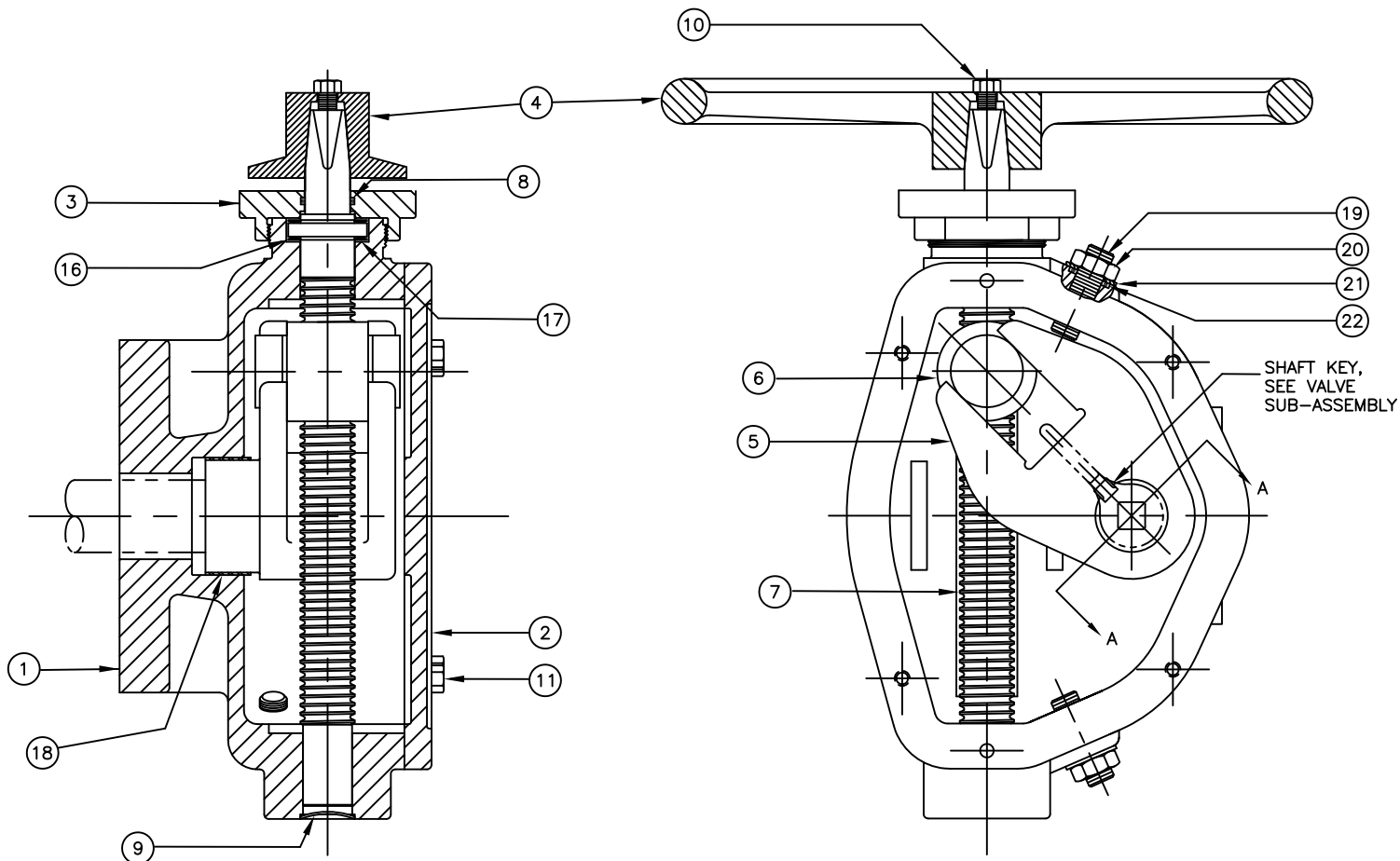

ITEM NO.	DESCRIPTION	MATERIAL
1	HOUSING, OPERATOR	CAST IRON, A-126 CL. B
2	COVER, HOUSING	CAST IRON, A-126 CL. B
3	CAP, THRUST	CAST IRON, A-126 CL. B
4	AS REQUIRED(handwheel or operator nut)	CAST IRON, A-126 CL. B
5	LEVER	DUCTILE IRON, A-536, GR. 65-45-12
6	CROSSHEAD	C.D. STEEL, 12L14
7	SHAFT, INPUT	C.D. STEEL, 12L14
8	SEAL, CAP	BUNA "N"
9	PLUG, EXPANSION	BRASS, COMMERCIAL
10	BOLT, HEXHEAD	STEEL, COMMERCIAL
11	BOLT, HEXHEAD (COVER)	STEEL, COMMERCIAL
12	INDICATOR	CAST IRON, A-126 CL. B
13	INDICATOR PIN	C.D. STEEL
14	SEAL (INDICATOR PIN)	BUNA "N"
15	NUT, HEX (INDICATOR PIN)	STEEL, COMMERCIAL
16	BEARING, NEEDLE THRUST	STEEL, COMMERCIAL
17	RACE, THRUST	HARDENED STEEL
18	BUSHING	NYLON (MOLY-DISULFIDE FILLED)
19	STUD (LEVER ADJUSTMENT)	STAINLESS STEEL, 18-8
20	NUT, HEX (LEVER ADJUSTMENT)	STEEL, COMMERCIAL
21	WASHER (LEVER ADJUSTMENT)	STEEL, COMMERCIAL
22	O-RING (LEVER ADJUSTMENT)	BUNA "N"

NOTE: ITEM 10 & 11 IS AVAILABLE IN 18-8/316 STAINLESS STEEL WHEN REQUESTED.

M&H VALVE COMPANY  
ANNISTON, ALABAMA  
A DIVISION OF MCWANE INC.

DWN: TRIJ  
DATE: 9/1/06  
DWG. NO.  
BFV-OP-4

SUB-ASSEMBLY / MATERIAL LIST  
M&H 510, 1250 & 2200 OPERATOR

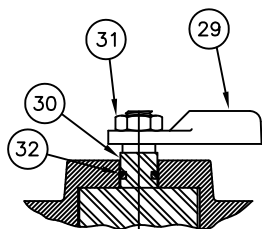
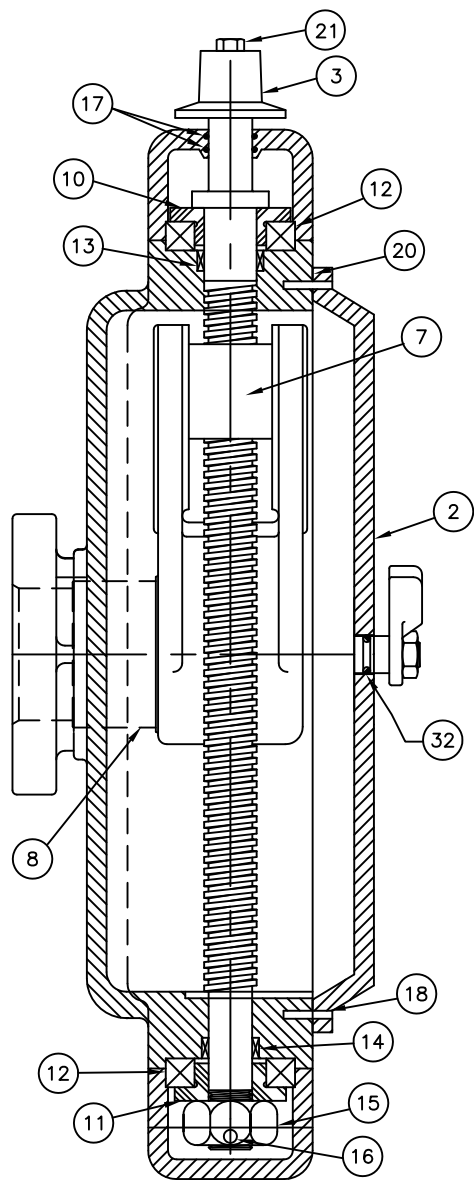

SECTION B-B

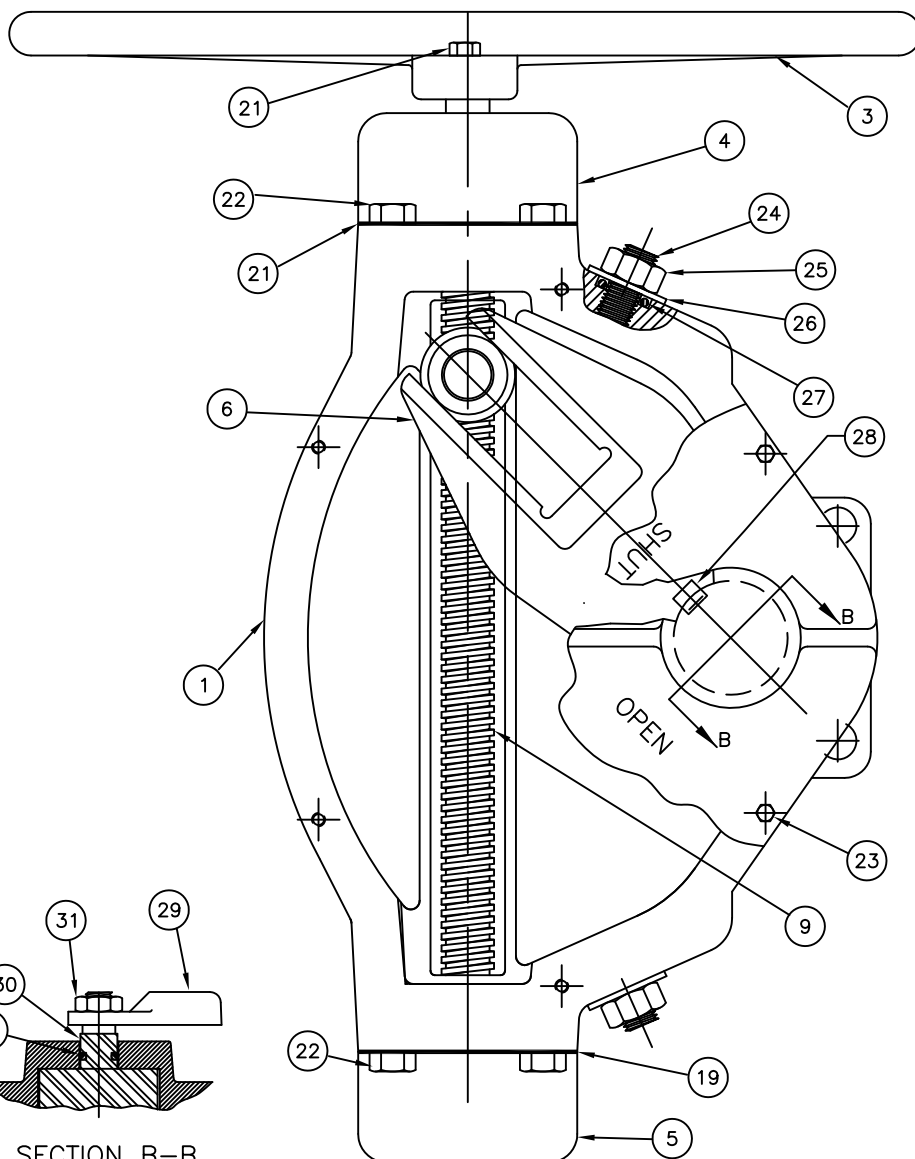

ITEM NO.	DESCRIPTION	MATERIAL	NO. REQ.
1	OPERATOR HOUSING	CAST IRON, ASTM A-126 CL. B	1
2	HOUSING COVER	CAST IRON, ASTM A-126 CL. B	1
3	OPERATOR NUT OR HANDWHEEL	CAST IRON, ASTM A-126 CL. B	1
4	END CAP (INPUT)	CAST IRON, ASTM A-126 CL. B	1
5	END CAP (LOCK NUT)	CAST IRON, ASTM A-126 CL. B	1
6	LEVER	DUCTILE IRON, ASTM A-536, GR. 65-45-12	1
7	CROSSHEAD	CDS 12L14	1
8	BUSHING	NYLATRON GS	1
9	INPUT SHAFT	CDS AISI C1141 (LEADED)	1
10	BEARING RETAINER	CDS AISI C1117 (LEADED)	1
11	BEARING RETAINER	CDS AISI C1117 LEADED	1
12	BALL THRUST BEARING	COMMERCIAL STEEL	2
13	SLEEVE BEARING	OILITE BRONZE	1
14	SLEEVE BEARING	OILITE BRONZE	1
15	SLOTTED NUT	COMMERCIAL STEEL	1
16	LOCK PIN	COMMERCIAL STEEL	1
17	END CAP SEAL	BUNA "N"	2

\* PARTS FOR HANDWHEEL ACTUATOR WITH POSITION INDICATOR

ITEM NO.	DESCRIPTION	MATERIAL	NO. REQ.
18	DOWEL PIN	STEEL, COMMERCIAL	2
19	END CAP GASKET	LOCTITE MASTER GASKET	2
20	COVER GASKET	LOCTITE MASTER GASKET	1
21	HEX HEAD CAP SCREW	COMMERCIAL STEEL	1
22	HEX HEAD CAP SCREW	COMMERCIAL STEEL	8
23	HEX HEAD CAP SCREW	COMMERCIAL STEEL	6
24	SETSCREW (LEVER ADJUSTMENT)	18-8 SS	2
25	HEX JAM NUT(LEVER ADJUSTMENT)	COM. STEEL-ASTM A563 GRADE A, ZINC PLATED-ASTM B-633	2
26	WASHER (LEVER ADJUSTMENT)	COM. STEEL-ASTM A563 GRADE A, ZINC PLATED-ASTM B-633	2
27	O-RING (LEVER ADJUSTMENT)	BUNA "N"	2
28	KEY	COMMERCIAL STEEL	1
*29	INDICATOR	CAST IRON A-126 CL. B	1
*30	INDICATOR PIN	COMMERCIAL STEEL	1
*31	NUT, HEX (INDICATOR PIN)	COMMERCIAL STEEL	1
*32	O-RING (INDICATOR PIN)	BUNA "N"	1

M&H VALVE COMPANY  
ANNISTON, ALABAMA  
A DIVISION OF MCWANE INC.

DWN: TRIJ  
DATE: 8/24/11  
DWG. NO.  
BFV-OP-2

SUB-ASSEMBLY / MATERIAL LIST  
M&H 4350 OPERATOR

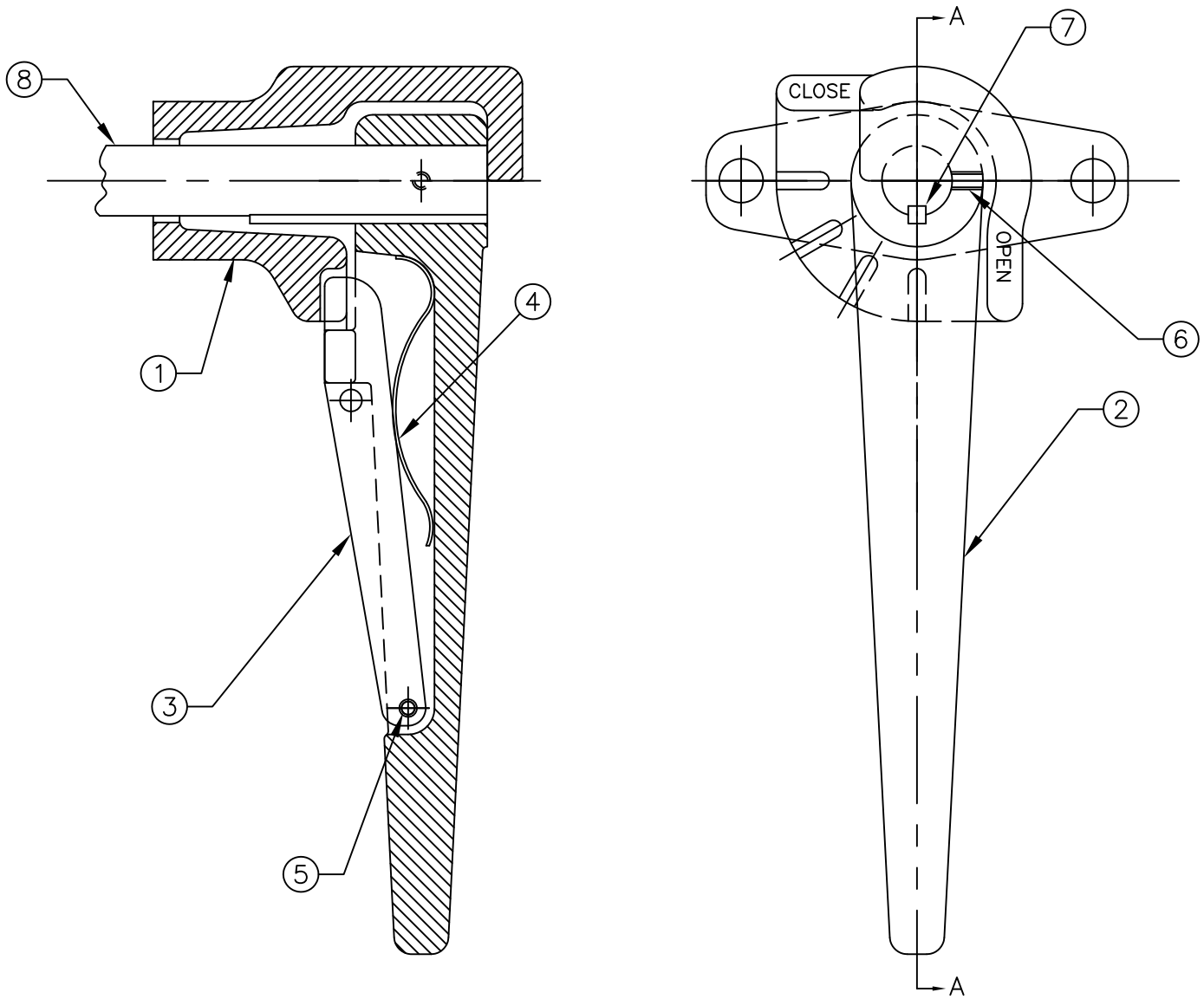

ITEM NO.	DESCRIPTION	MATERIAL
1	BRACKET	CAST IRON; A-126, CL. B
2	LEVER	CAST IRON; A-126, CL. B
3	LATCH	CAST IRON; A-126, CL. B
4	SPRING	SPRING STEEL, CADMIUM PLATED
5	SPRING PIN	STEEL; CADMIUM PLATED
6	SCREW, SOCKET SET	ALLOY STEEL
7	KEY	C-1018 C.F.
8	SHAFT	STAINLESS STEEL, TYPE 304

M&H VALVE COMPANY  
ANNISTON, ALABAMA  
A DIVISION OF MCWANE INC.

DWN: TRIJ  
DATE: 8/24/11  
DWG. NO.  
BFV-OP-3

4"-6"-8"  
LEVER OPERATOR  
SUB-ASSEMBLY / MATERIAL LIST