

CLOW CANADA

350 - 500 R/W GV MJ END BEVEL GEAR
GENERAL DIMENSIONS

PROJECT

OWNER

CONTRACTOR

DISTRIBUTOR

CONSULTANT

CLOW FIGURE NUMBER F-6100-BG

CLOW MODEL 2638 AWWA C515
REDUCED WALL DUCTILE IRON

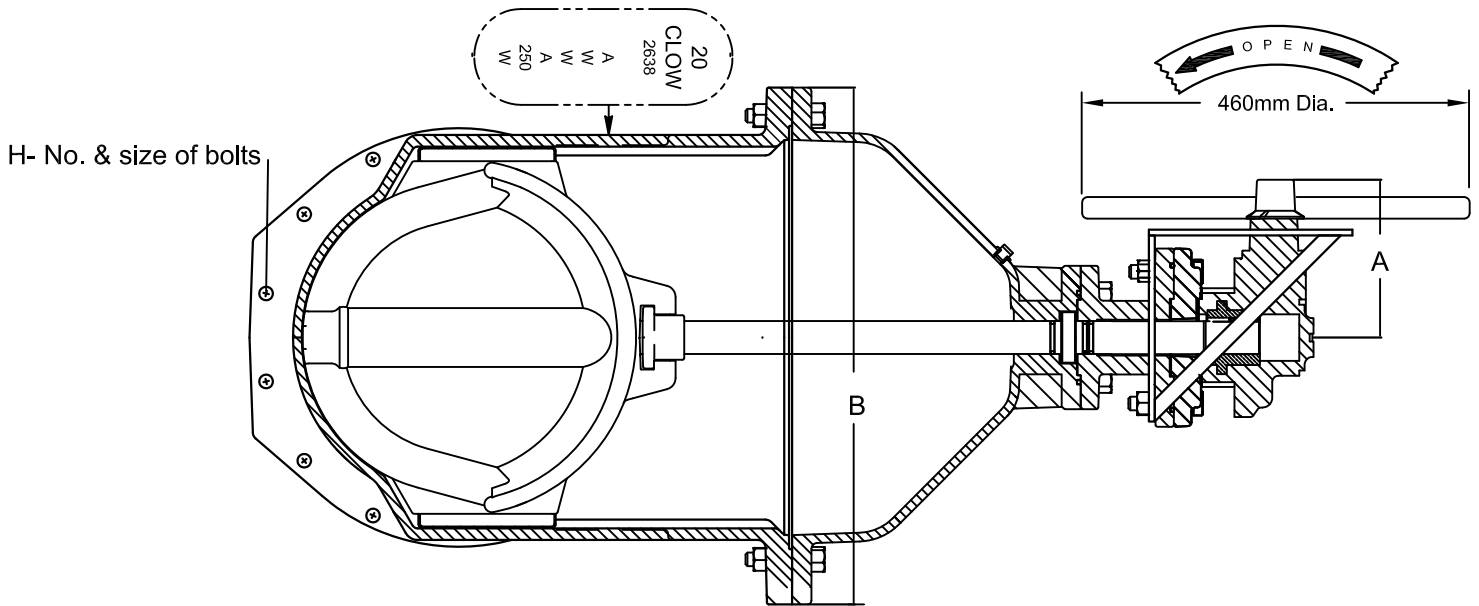
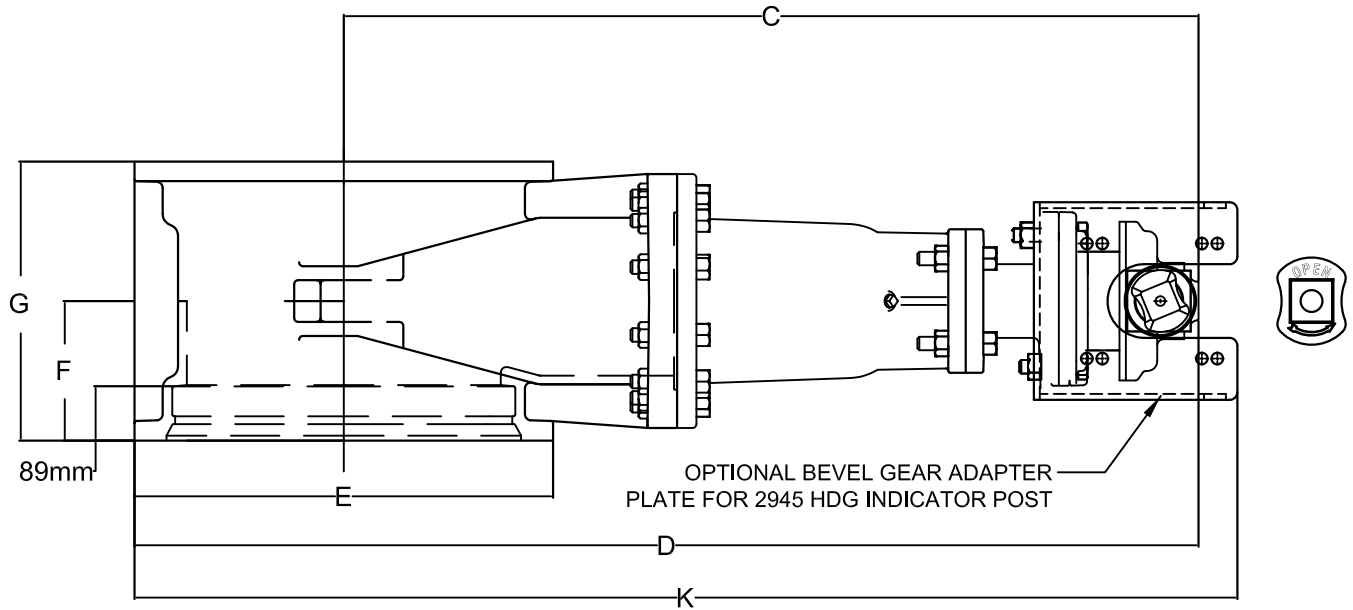

METRIC DIMENSIONS										NUMBER of TURNS NO GEAR	NUMBER of TURNS W/ GEAR	WEIGHT W/2" NUT	WEIGHT W/HW	WEIGHT W/BG ADAPT. PLATE	
VALVE SIZE	A	B	C	D	E	F	G	H	J						K
350 mm	230	675	1160	1500	515	215	430	10-3/4	1185	1655	52	100	740 lbs	760 lbs	770 lbs
400 mm	230	675	1210	1500	570	215	430	12-3/4	1160	1655	52	100	785 lbs	805 lbs	815 lbs
450 mm	260	820	1415	1735	630	230	475	12-3/4	1365	1890		189	1325 lbs	1345 lbs	1355 lbs
500 mm	260	820	1390	1735	685	230	460	14-3/4	1340	1890		189	1325 lbs	1345 lbs	1355 lbs