

# CLOW CANADA

350 - 500 R/W GV MJ END SPUR GEAR  
GENERAL DIMENSIONS

PROJECT

OWNER

CONTRACTOR

DISTRIBUTOR

CONSULTANT

CLOW FIGURE NUMBER F-6100-SG

CLOW MODEL 2638 AWWA C515  
REDUCED WALL DUCTILE IRON

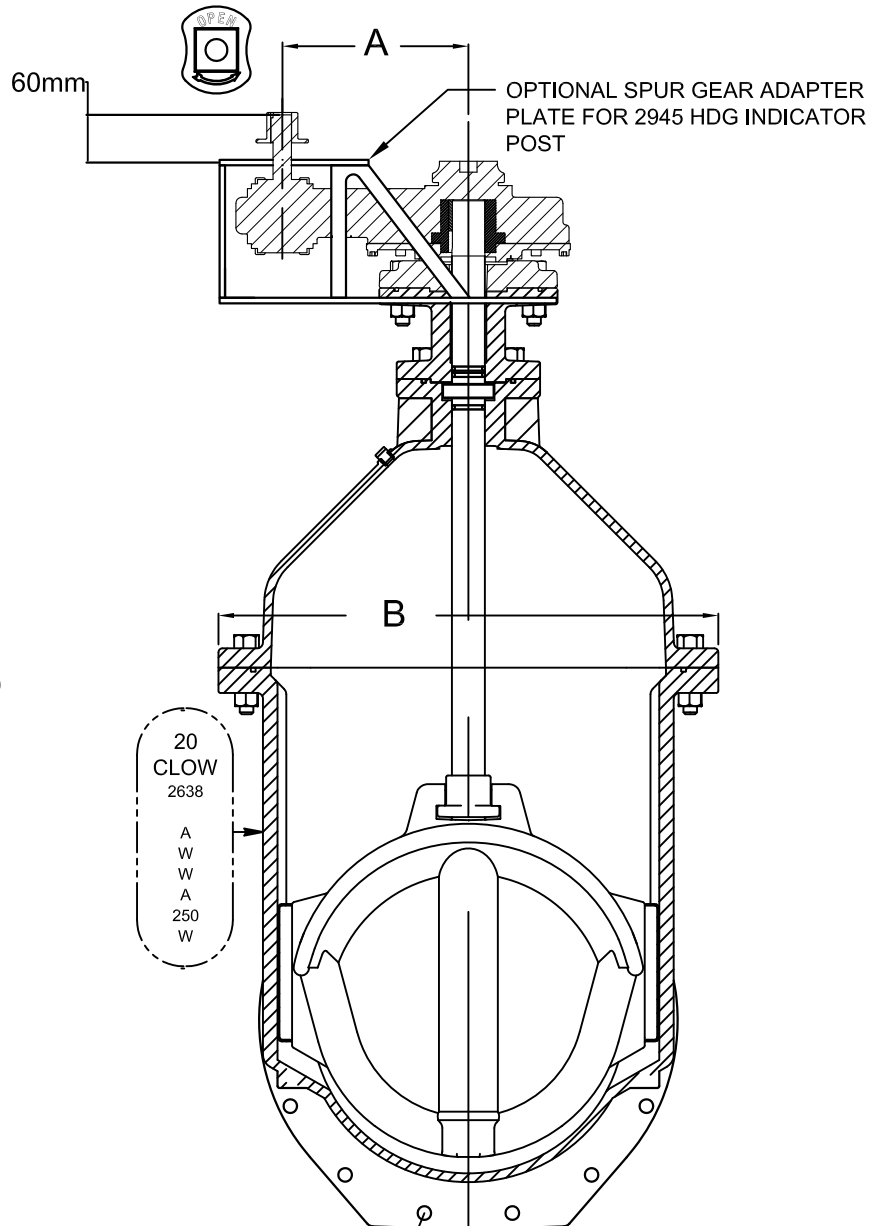
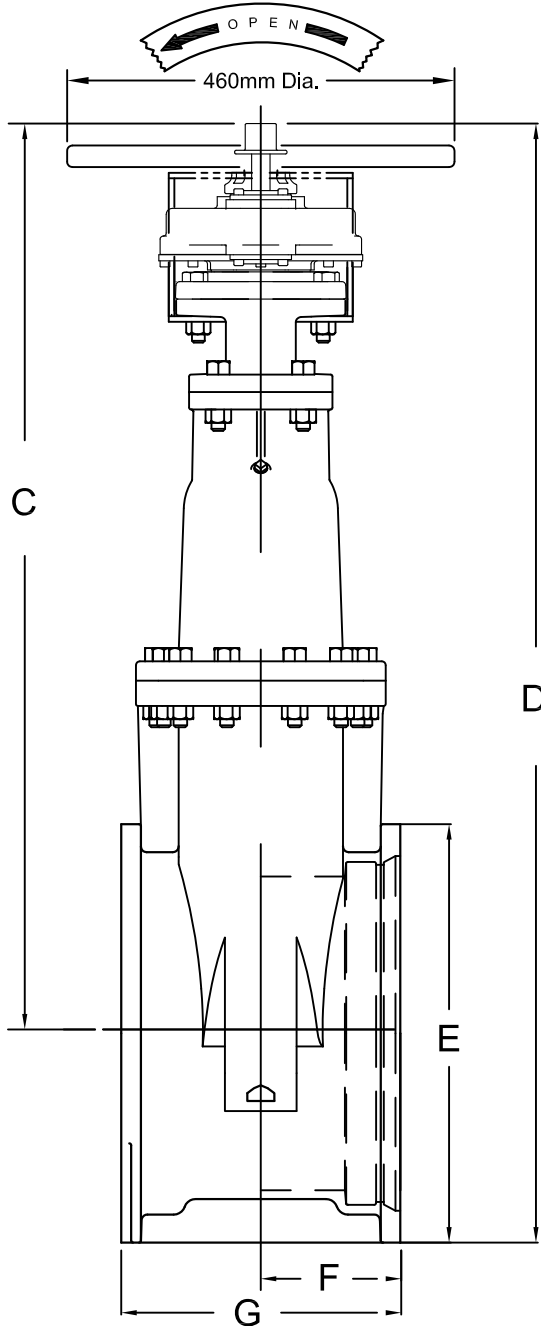

H - No. & SIZE OF BOLTS  
DRILLING PER ANSI B16.1  
Class 125

## METRIC DIMENSIONS

VALVE SIZE	A	B	C	D	E	F	G	H	NUMBER of TURNS NO GEAR	NUMBER of TURNS W/ GEAR	WEIGHT W/2" NUT	WEIGHT W/HW	WEIGHT W/BG ADAPT. PLATE
350 mm	200	675	1235	1510	515	215	430	10-3/4	52	100	775 lbs	795 lbs	805 lbs
400 mm	300	675	1210	1510	570	215	430	12-3/4	52	100	820 lbs	840 lbs	850 lbs
450 mm	300	820	1485	1800	630	230	475	12-3/4		189	1360 lbs	1380 lbs	1465 lbs
500 mm	300	820	1485	1800	685	230	460	14-3/4		189	1360 lbs	1380 lbs	1465 lbs