

# CLOW CANADA

350mm - 400mm R/W VALVE MECHANICAL JOINT  
GENERAL DIMENSIONS

PROJECT

OWNER

CONTRACTOR

DISTRIBUTOR

CONSULTANT

CLOW FIGURE NUMBER F-6100

CLOW MODEL 2638 AWWA C515  
REDUCED WALL DUCTILE IRON

**OPTIONAL**

- 1) HANDWHEEL
- 2) 2" OP. NUT & PI PLATE
- 3) 2" OP. NUT
- 4) RED NUT or H/W = OPEN RIGHT
- 5) BLACK NUT or H/W = OPEN LEFT

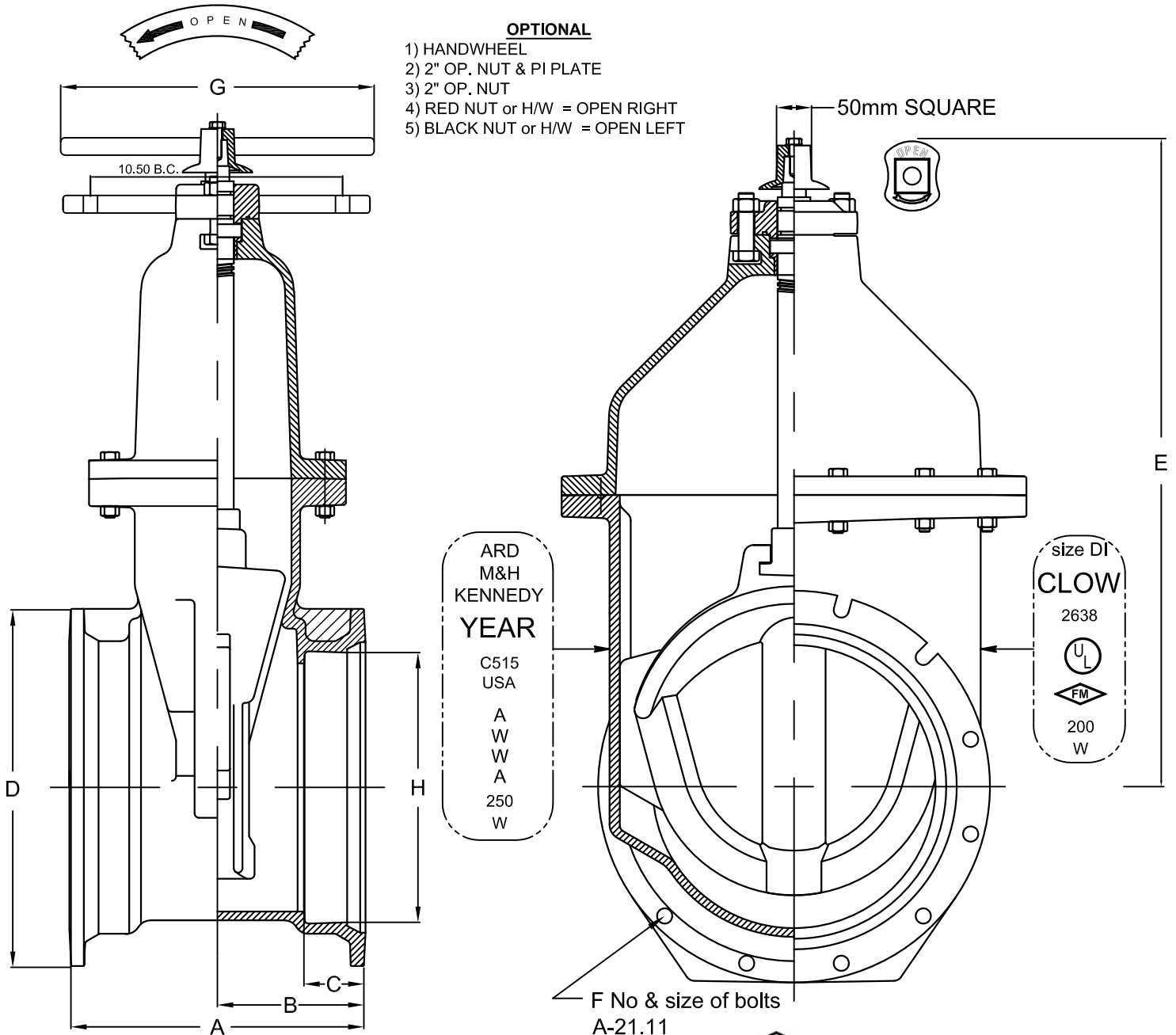

**350mm & 400mm MECHANICAL JOINT VALVE METRIC DIMENSIONS**

VALVE SIZE	A	B	C	D	E	F	G	H	NUMBER of TURNS	WEIGHT W/2" NUT	WEIGHT W/HW	WEIGHT PI PLATE
350	432	216	89	514	959	10 - 19	457	362	52	625 lbs	644 lbs	641 lbs
400	432	216	89	572	959	12 - 19	457	413	52	675 lbs	694 lbs	691 lbs