

2638-62
E 10/10

Complies with applicable
requirements of AWWA C515

30"-48" R/W VALVE MJ x FLG ENDS SPUR
GEAR GENERAL DIMENSIONS

CLOW VALVE COMPANY

MODEL 2638

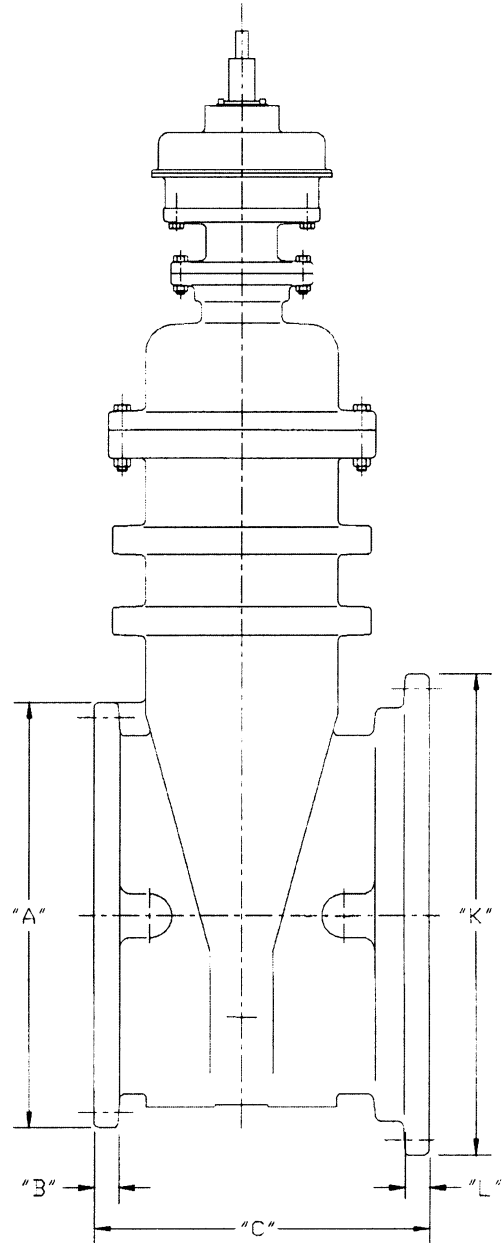
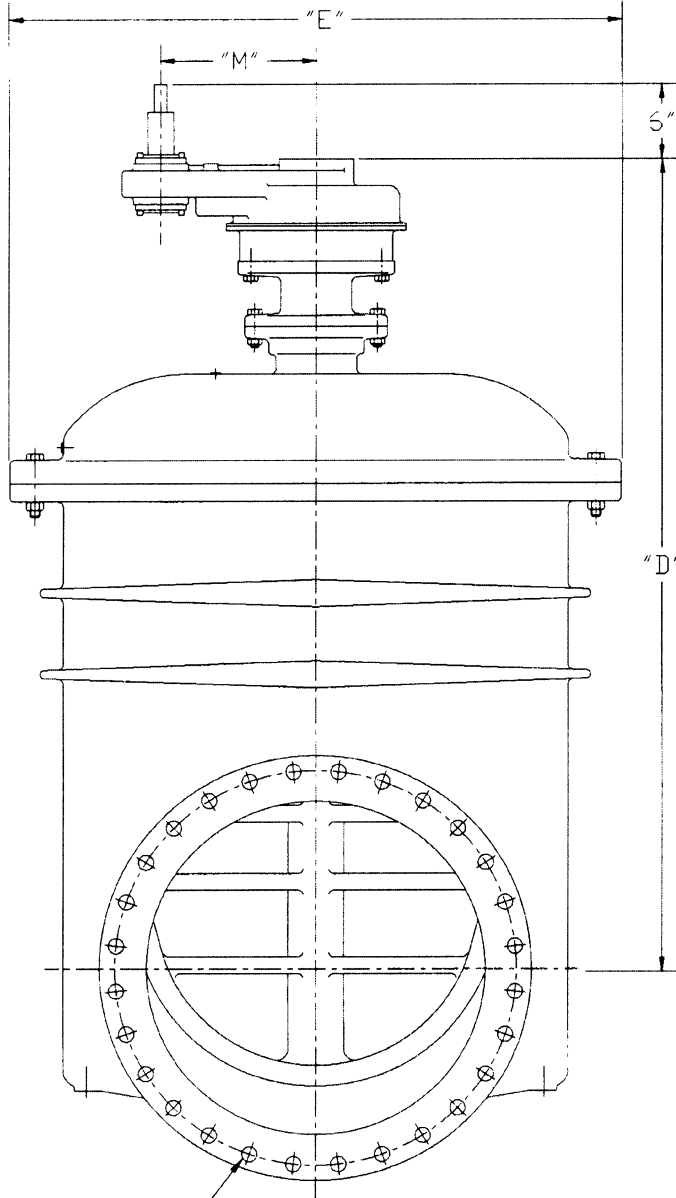

Flange End: ANSI B16.1 Class 125
Drilling for "F" # & "G" Size Bolts
MJ End: ANSI/AWWA C111/A21.11
Drilling for "H" # & "J" Size Bolts

Valve Size	"A"	"B"	"C"	"D"	"E"	"F"	"G"	"H"	"J"	"K"	"L"	"M"
30"	38-3/4	2-1/8	31	74	54-3/4	28	1-1/4	20	1"	39-1/2	1-11/16	14
36"	46	2-3/8	34-3/4	83-11/16	58-7/8	32	1-1/2	24	1"	46-1/2	2	14
42"	53	2-5/8	37-1/2	102-1/2	78	36	1-1/2	28	1-1/4	54	2	16
48"	59-1/2	2-3/4	39	105-1/2	78	44	1-1/2	32	1-1/4	60-3/4	2	16