

CLOW CANADA

350mm - 500mm R/W VALVE FLANGED END
BEVEL GEAR GENERAL DIMENSIONS

PROJECT

OWNER

CONTRACTOR

DISTRIBUTOR

CONSULTANT

CLOW FIGURE NUMBER F-6102-BG

CLOW MODEL 2638 AWWA C515
REDUCED WALL DUCTILE IRON

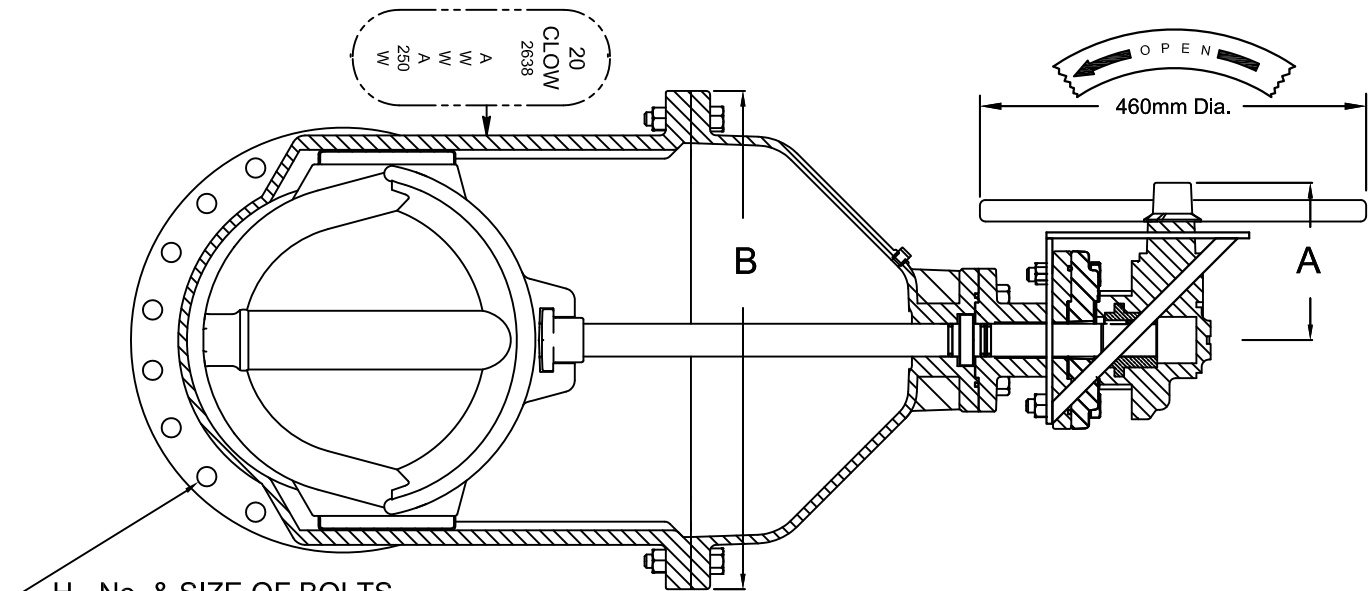
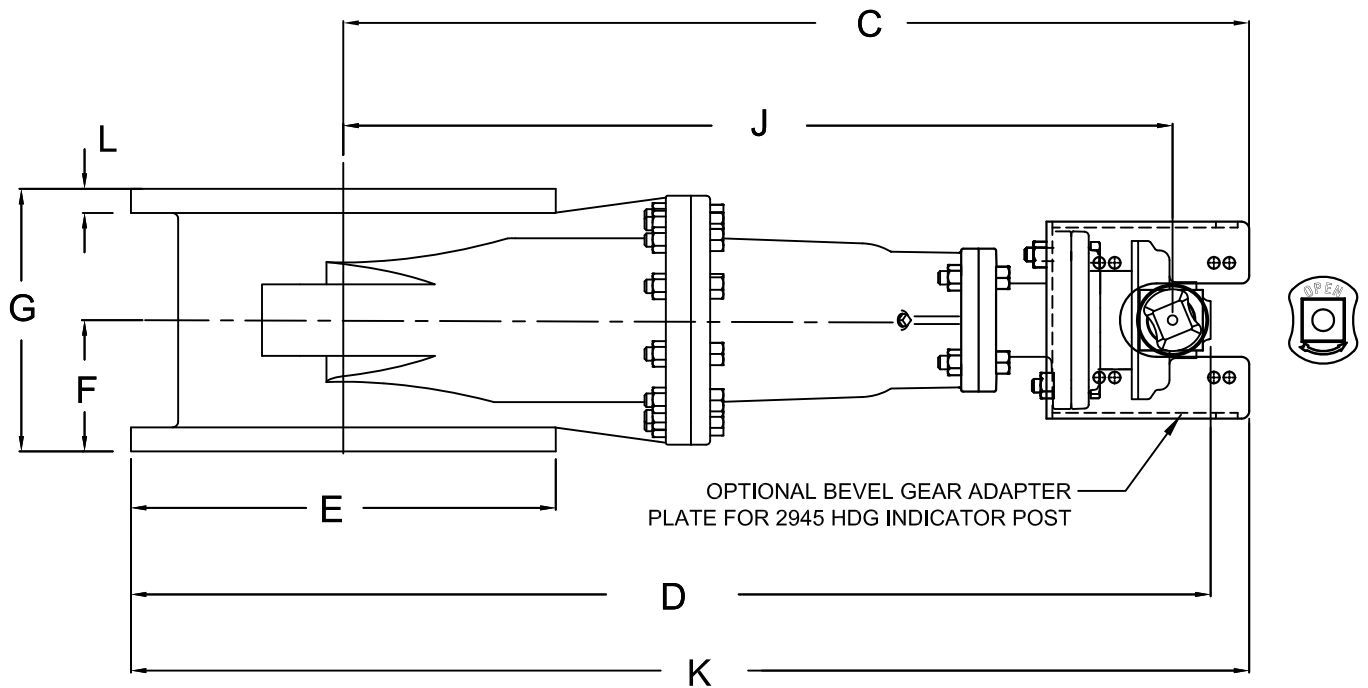

H - No. & SIZE OF BOLTS
DRILLING PER ANSI B16.1
Class 125

METRIC DIMENSIONS												NUMBER of TURNS NO GEAR	NUMBER of TURNS W/ GEAR	WEIGHT W/2" NUT	WEIGHT W/HW	WEIGHT W/BG ADAPT. PLATE
VALVE SIZE	A	B	C	D	E	F	G	H (Inches)	J	K	L					
350mm	230	680	1235	1510	535	190	380	12-1	1180	1570	35	52	100	665 lbs	685 lbs	695 lbs
400mm	230	680	1210	1510	595	205	406	16-1	1150	1570	36	52	100	720 lbs	740 lbs	750 lbs
450mm	260	820	1420	1735	635	215	432	16-1 1/8	1365	1806	40		189	1425 lbs	1445 lbs	1455 lbs
500mm	260	820	1390	1735	700	230	457	20-1 1/8	1340	1813	43		189	1350 lbs	1370 lbs	1380 lbs

Design and materials subject to change without notice. June 2016