

CLOW CANADA

350mm - 500mm FLANGED RW GATE VALVE
WITH SPUR GEAR

PROJECT

OWNER

CONTRACTOR

DISTRIBUTOR

CONSULTANT

CLOW FIGURE NUMBER F-6102-SG

CLOW MODEL 2638 AWWA C515
REDUCED WALL DUCTILE IRON

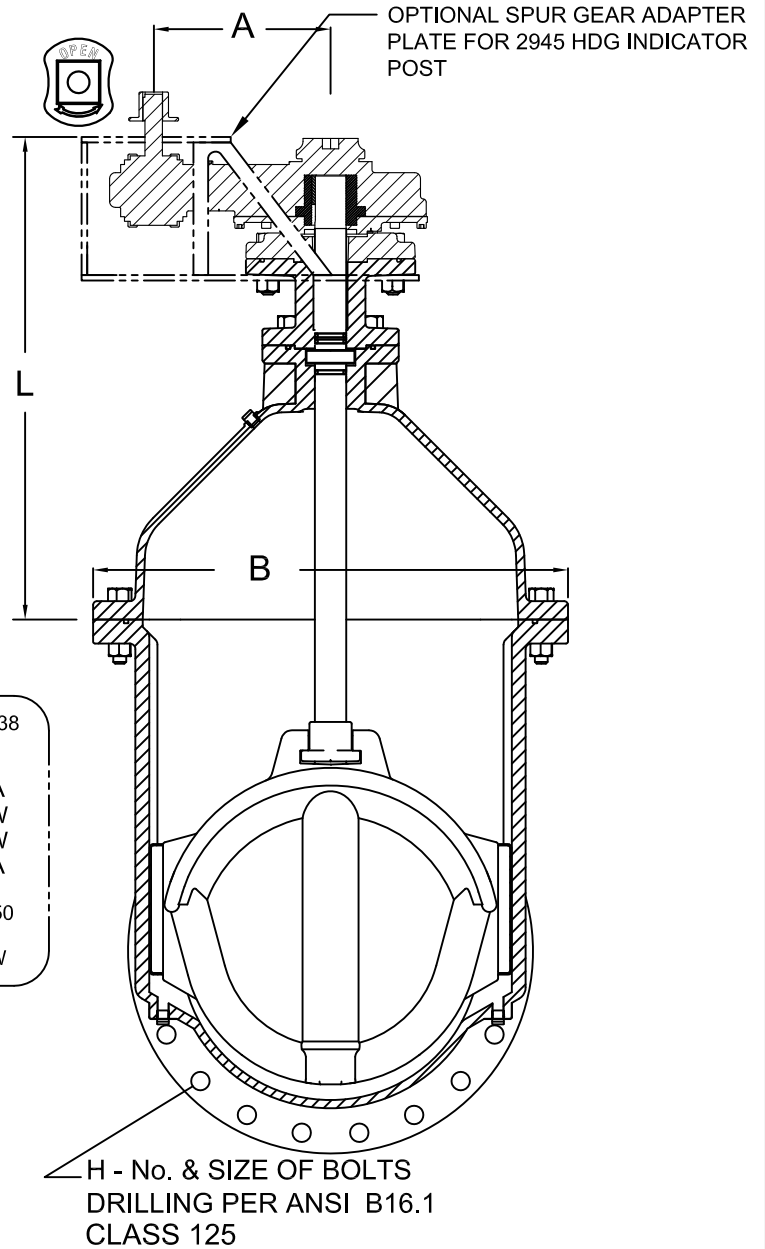
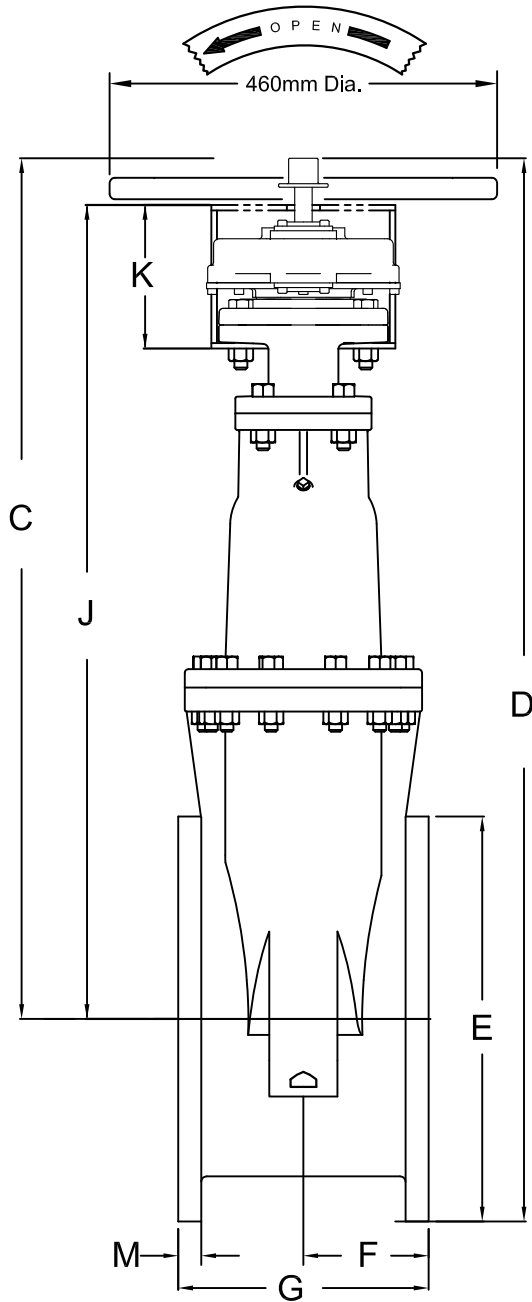

METRIC DIMENSIONS													NUMBER of TURNS NO GEAR	NUMBER of TURNS W/ GEAR	WEIGHT W/2" NUT	WEIGHT W/HW	WEIGHT W/SG ADAPT. PLATE
VALVE SIZE	A	B	C	D	E	F	G	H	J	K	L	M					
350mm	200	680	1300	1600	535	190	380	12 - 1"	1235	254	450	35	52	100	700 lbs	720 lbs	730 lbs
400mm	200	680	1335	1600	595	205	406	16 - 1"	1270	254	425	36	52	100	755 lbs	775 lbs	785 lbs
450mm	300	820	1450	1790	635	215	432	16 - 1 1/8"	1385	254	563	40	-----	189	1460 lbs	1480 lbs	1490 lbs
500mm	300	820	1475	1790	700	230	457	20 - 1 1/8"	1410	254	538	43	-----	189	1385 lbs	1405lbs	1415 lbs

Design and Materials Subject to Change Without Notice. Nov. 2013