

# CLOW CANADA

PROJECT

OWNER

CONTRACTOR

DISTRIBUTOR

CONSULTANT

## 350mm - 400mm R/W VALVE FLANGED END GENERAL DIMENSIONS

CLOW FIGURE NUMBER F-6102

CLOW MODEL 2638 AWWA C515  
REDUCED WALL DUCTILE IRON

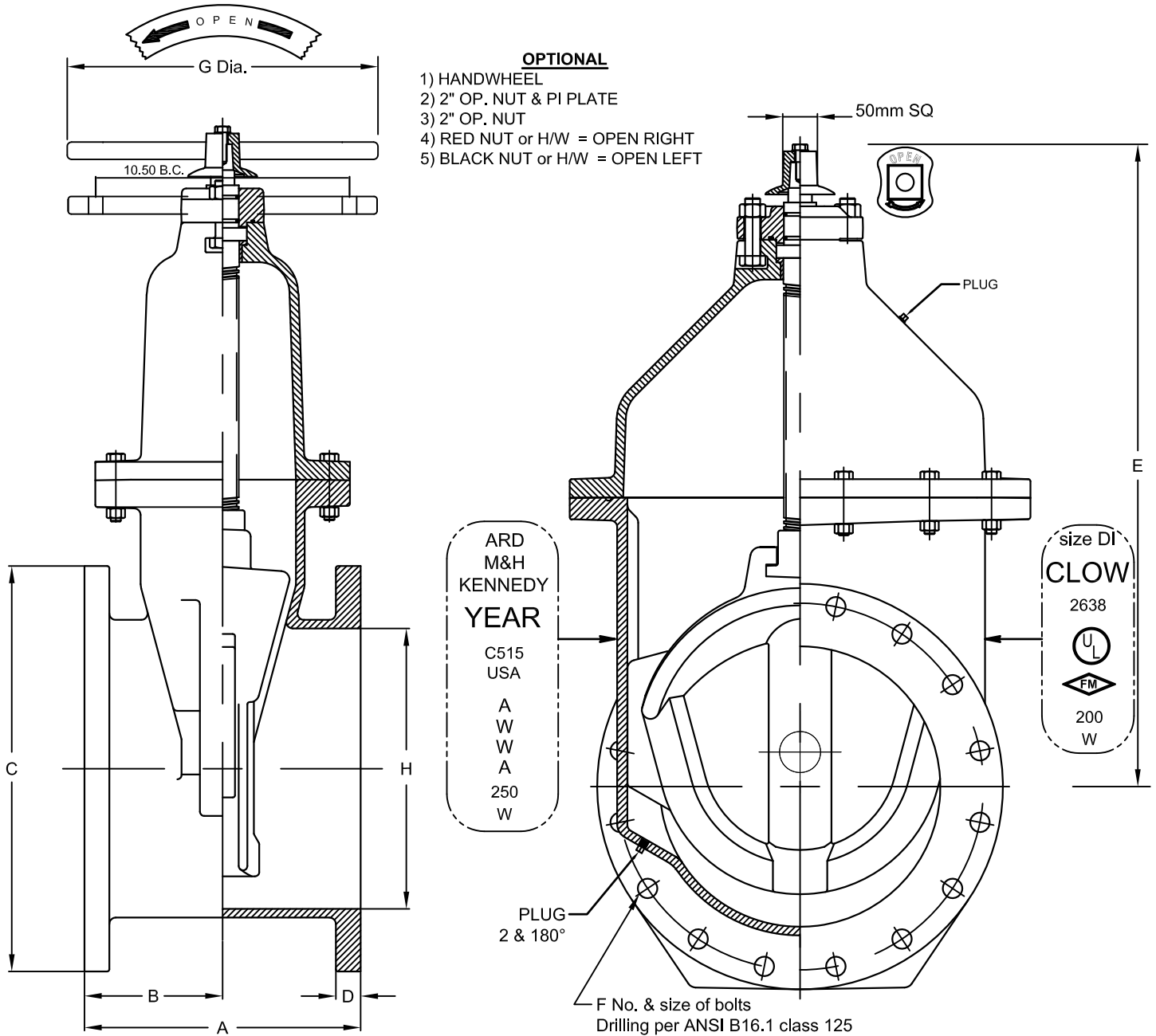

### 350mm & 400mm FLANGED VALVE METRIC DIMENSIONS

VALVE SIZE	A	B	C	D	E	F	G	H	NUMBER of TURNS NO GEAR	WEIGHT W/2" NUT	WEIGHT W/HW	WEIGHT PI PLATE
350	381	190	533	35	959	12-25	457	362	52	665 lbs	690 lbs	681 lbs
400	406	203	597	37	959	16-25	457	416	52	720 lbs	745 lbs	736 lbs