

# CLOW CANADA

50 - 75 R/W VALVE NRS THREADED ENDS  
GENERAL DIMENSIONS

PROJECT

OWNER

CONTRACTOR

DISTRIBUTOR

CONSULTANT

CLOW FIGURE F6103

CLOW MODEL 2640 AWWA C509 FULL WALL CAST IRON

CLOW MODEL 2639 AWWA C509 FULL WALL DUCTILE IRON

**OPTIONAL**

- 1) HANDWHEEL
- 2) 2" OP. NUT & PI PLATE
- 3) 2" OP. NUT
- 4) RED NUT or H/W = OPEN RIGHT
- 5) BLACK NUT or H/W = OPEN LEFT

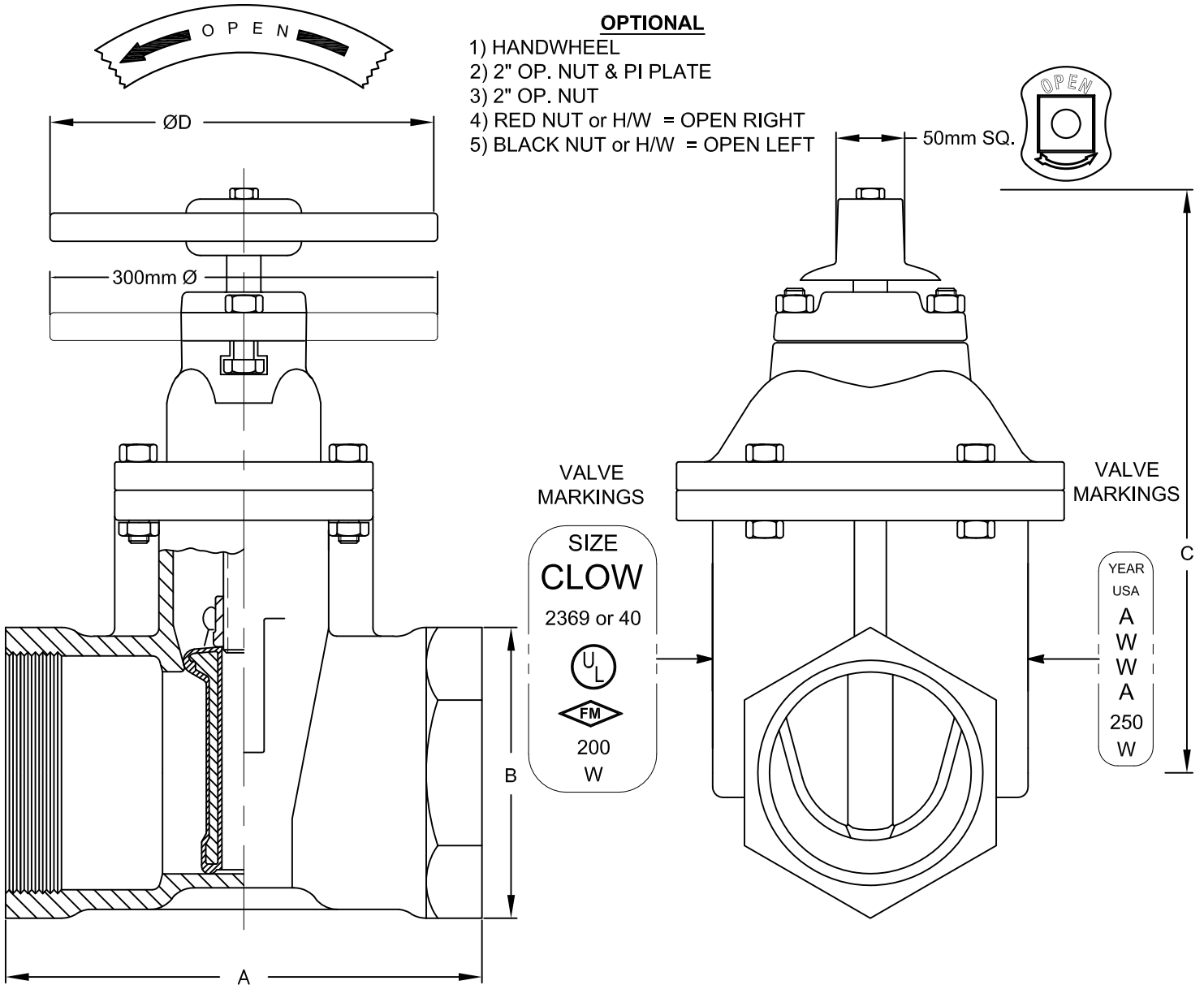

VALVE SIZE	METRIC DIMENSIONS				NUMBER OF TURNS	WEIGHT W/2" NUT	WEIGHT W/ HW	WEIGHT PI PLATE
	A	B	C	D				
50	133	105	275	185	6 1/2	33 lbs	39 lbs	—
62.5	175	130	290	185	8	44 lbs	50 lbs	—
75	180	140	315	250	10	50 lbs	56 lbs	66 lbs