

CLOW CANADA

350 - 400 R/W VALVE FLG x MJ END
GENERAL DIMENSIONS

PROJECT

OWNER

CONTRACTOR

DISTRIBUTOR

CONSULTANT

CLOW FIGURE NUMBER F-6106

CLOW MODEL 2638 AWWA C515
REDUCED WALL DUCTILE IRON

OPTIONAL

- 1) HANDWHEEL
- 2) 2" OP. NUT & PI PLATE
- 3) 2" OP. NUT
- 4) RED NUT or H/W = OPEN RIGHT
- 5) BLACK NUT or H/W = OPEN LEFT

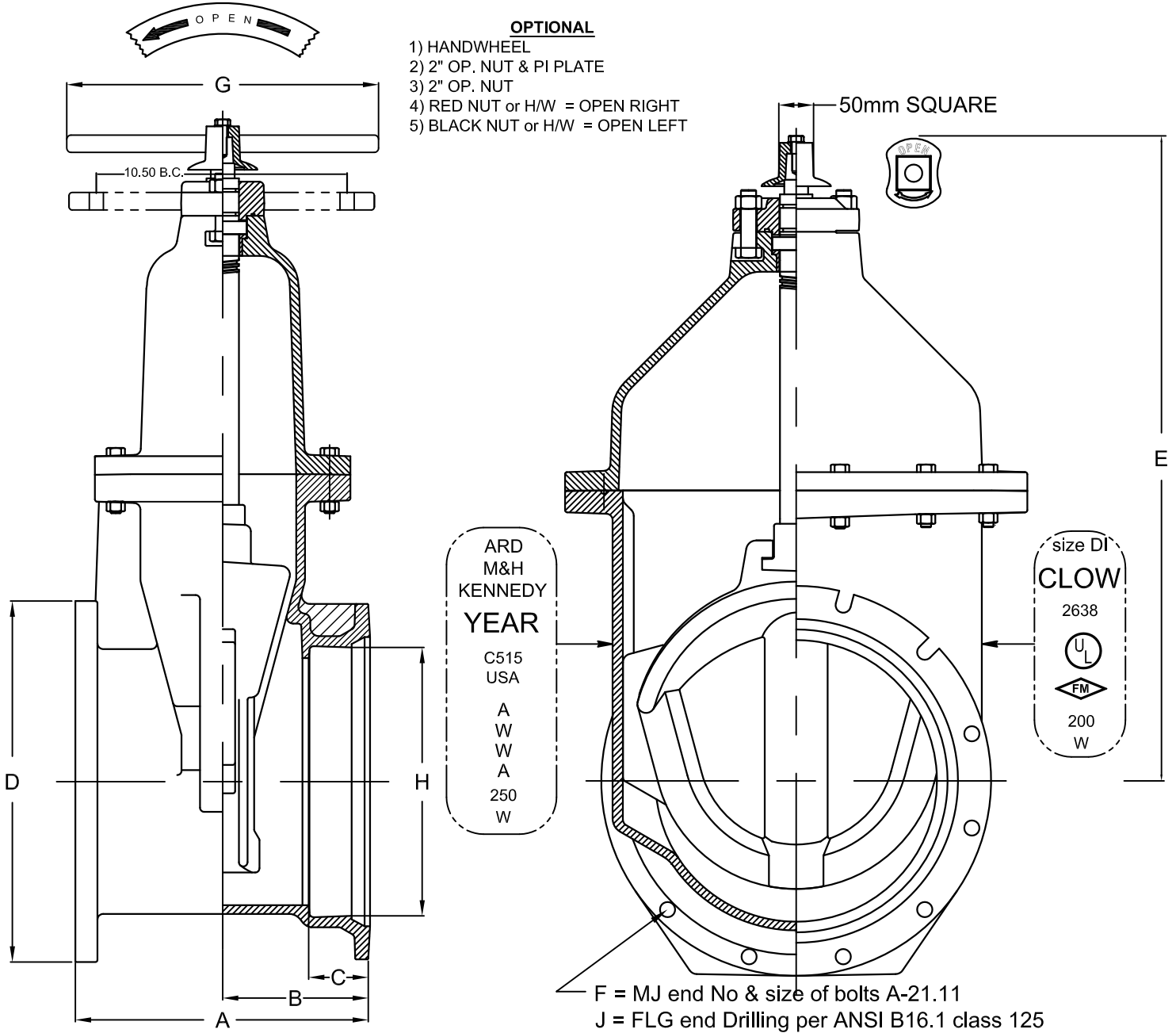

350mm & 400mm FLANGED x M.J. VALVE METRIC DIMENSIONS

VALVE SIZE	A	B	C	D	E	F	G	H	J	NUMBER of TURNS	WEIGHT W/2" NUT	WEIGHT W/HW	WEIGHT PI PLATE
350	430	215	89	533	959	10 - 19	457	362	12 - 25	52	750 lbs	768 lbs	766 lbs
400	430	215	89	597	959	12 - 19	457	413	16 - 25	52	850 lbs	868 lbs	866 lbs