

CLOW CANADA

350 - 500 R/W VALVE MJ x FLG END
BEVEL GEAR GENERAL DIMENSIONS

CLOW FIGURE NUMBER F6106BG

CLOW MODEL 2638 AWWA C515
REDUCED WALL DUCTILE IRON

PROJECT

OWNER

CONTRACTOR

DISTRIBUTOR

CONSULTANT

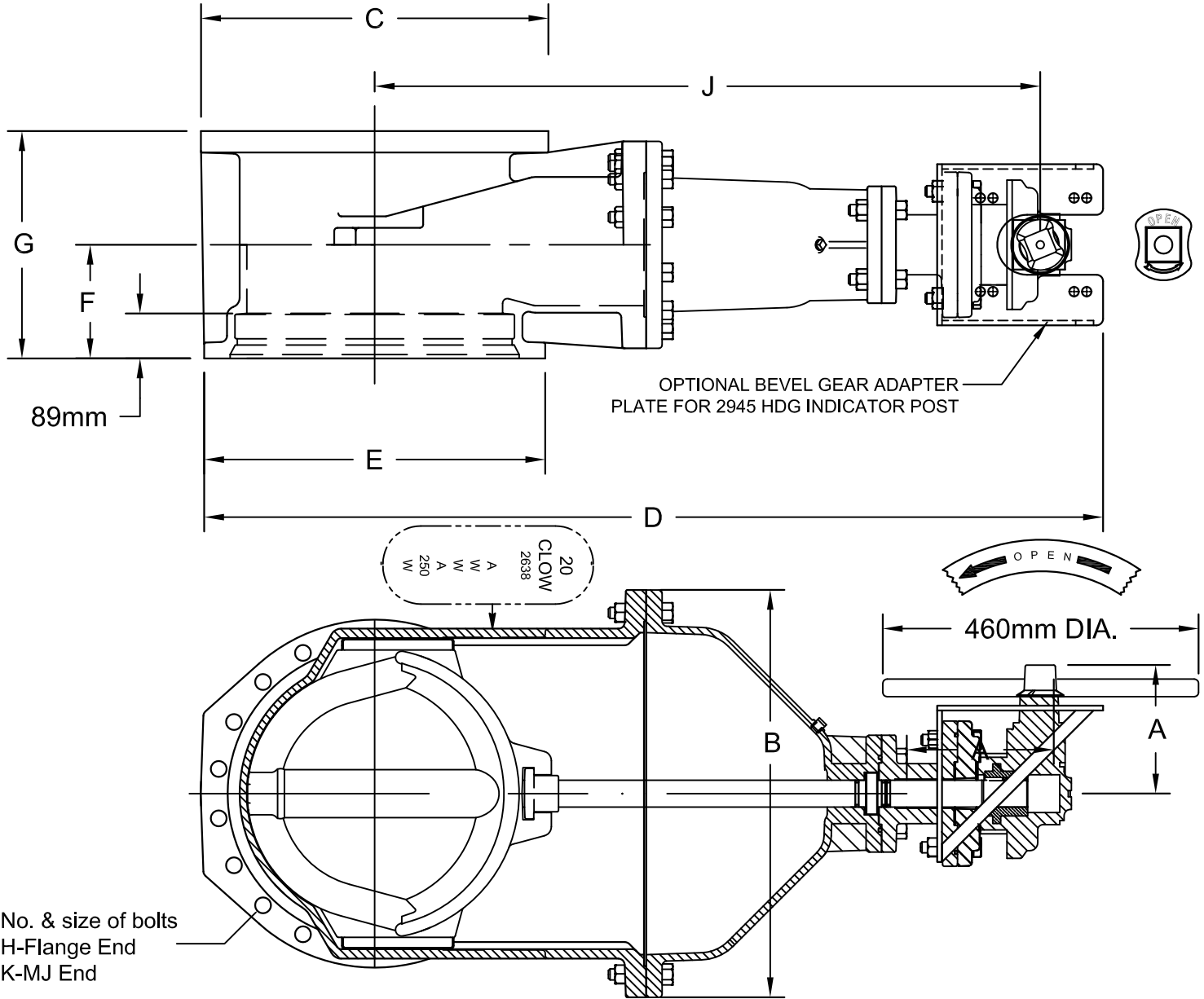

ALL DIMENSIONS IN MILLIMETERS

VALVE SIZE	A	B	C	D	E	F	G	H	J	K	NUMBER OF TURNS NO GEAR	NUMBER OF TURNS W/ GEAR	WEIGHT W/2" NUT	WEIGHT W/ H/W/H	WEIGHT W/BG ADAPT. PLATE
350 mm	230	675	535	1608	515	215	430	12-1 1/8	1185	10-3/4	52	100	750 lbs	770 lbs	780 lbs
400 mm	230	675	595	1613	570	215	430	16-1	1160	12-3/4	52	100	850 lbs	870 lbs	880 lbs
450 mm	260	820	635	1838	630	230	475	16-1 1/8	1365	12-3/4		189	1400 lbs	1420 lbs	1430 lbs
500 mm	260	820	700	1846	685	230	460	20-1 1/8	1340	14-3/4		189	1500 lbs	1520 lbs	1530 lbs