

# CLOW CANADA

350 - 500 R/W VALVE MJ x FLG END  
SPUR GEAR GENERAL DIMENSIONS

CLOW FIGURE NUMBER F6106SG

CLOW MODEL 2638 AWWA C515  
REDUCED WALL DUCTILE IRON

PROJECT

OWNER

CONTRACTOR

DISTRIBUTOR

CONSULTANT

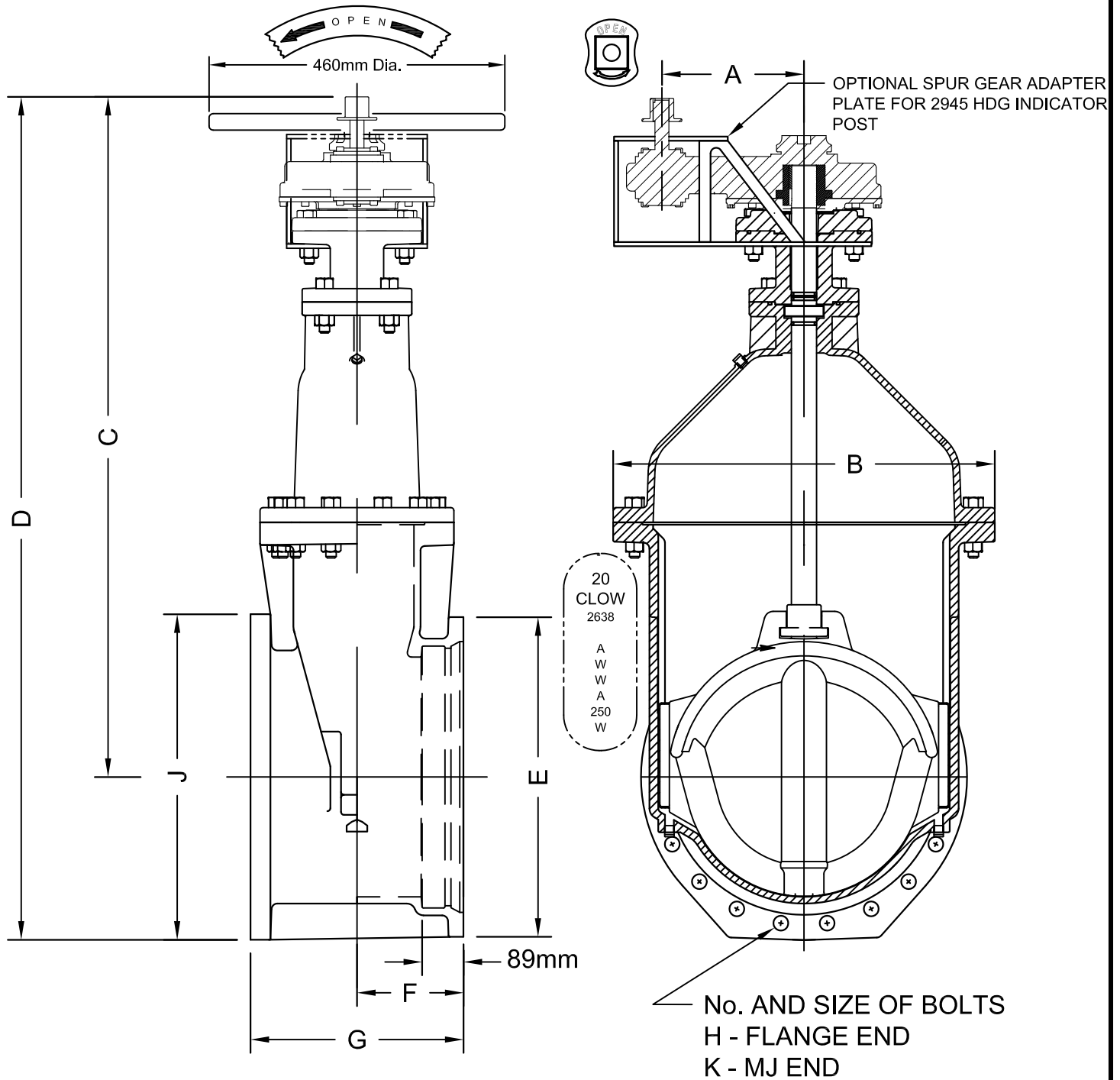

## ALL DIMENSIONS IN MILLIMETERS

VALVE SIZE	A	B	C	D	E	F	G	H	J	K	No. OF TURNS NO GEAR	No. OF TURNS W/GEAR	WEIGHT W/2" NUT	WEIGHT W/ H/W/H	WEIGHT W/SG ADAPT PLATE
350 mm	203	675	1300	1588	515	215	430	12 - 1"	535	10-3/4	52	100	785 lbs	805 lbs	815 lbs
400 mm	203	675	1335	1588	570	215	430	16-1"	595	12-3/4	52	100	885 lbs	908 lbs	915 lbs
450 mm	305	820	1450	1790	630	230	475	16-1 1/8"	635	12-3/4		189	1435 lbs	1455 lbs	1465 lbs
500 mm	305	820	1475	1790	685	230	460	20-1 1/8"	700	14-3/4		189	1535 lbs	1555 lbs	1565 lbs