

CLOW CANADA

50mm - 200mm R/W VALVE PVC ENDS
NRS GENERAL DIMENSIONS

PROJECT

OWNER

CONTRACTOR

DISTRIBUTOR

CONSULTANT

CLOW FIGURE F6110

CLOW MODEL 2640 AWWA C509 FULL WALL CAST IRON

CLOW MODEL 2639 AWWA C509 FULL WALL DUCTILE IRON

OPTIONAL

- 1) HANDWHEEL
- 2) 2" OP. NUT & PI PLATE
- 3) 2" OP. NUT
- 4) RED NUT or H/W = OPEN RIGHT
- 5) BLACK NUT or H/W = OPEN LEFT

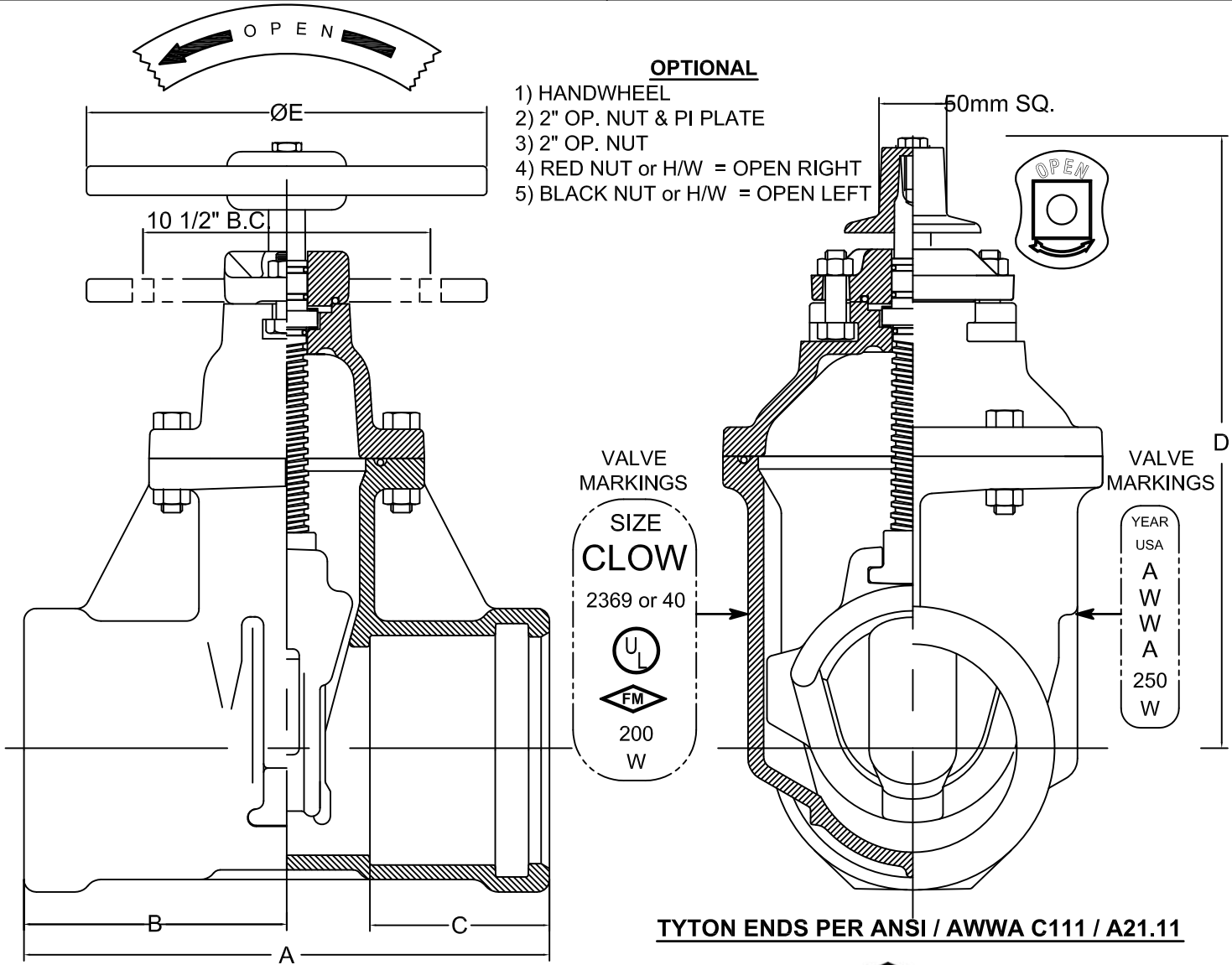

TYTON ENDS PER ANSI / AWWA C111 / A21.11



METRIC DIMENSIONS						NUMBER OF TURNS	WEIGHT W/2" NUT	WEIGHT W/ HW	WEIGHT PI PLATE
VALVE SIZE	A	B	C	D	E				
50	250	127	90	275	185	6 1/2	37 lbs	43 lbs	—
62.5	270	135	95	290	185	8	47 lbs	53 lbs	—
75	295	145	105	315	250	10	57 lbs	63 lbs	73 lbs
100	340	170	115	375	250	13 1/2	85 lbs	91 lbs	101 lbs
150	400	200	135	480	300	19 1/2	220 lbs	229 lbs	236 lbs
200	410	205	135	570	350	25 1/2	220 lbs	229 lbs	236 lbs