

CLOW CANADA

100mm - 300mm R/W VALVE
MECHANICAL JOINT ONE END OVERSIZE
GENERAL DIMENSIONS

PROJECT

OWNER

CONTRACTOR

DISTRIBUTOR

CONSULTANT

CLOW FIGURE F6111

CLOW MODEL 2640 AWWA C509 FULL WALL CAST IRON

CLOW MODEL 2639 AWWA C509 FULL WALL DUCTILE IRON

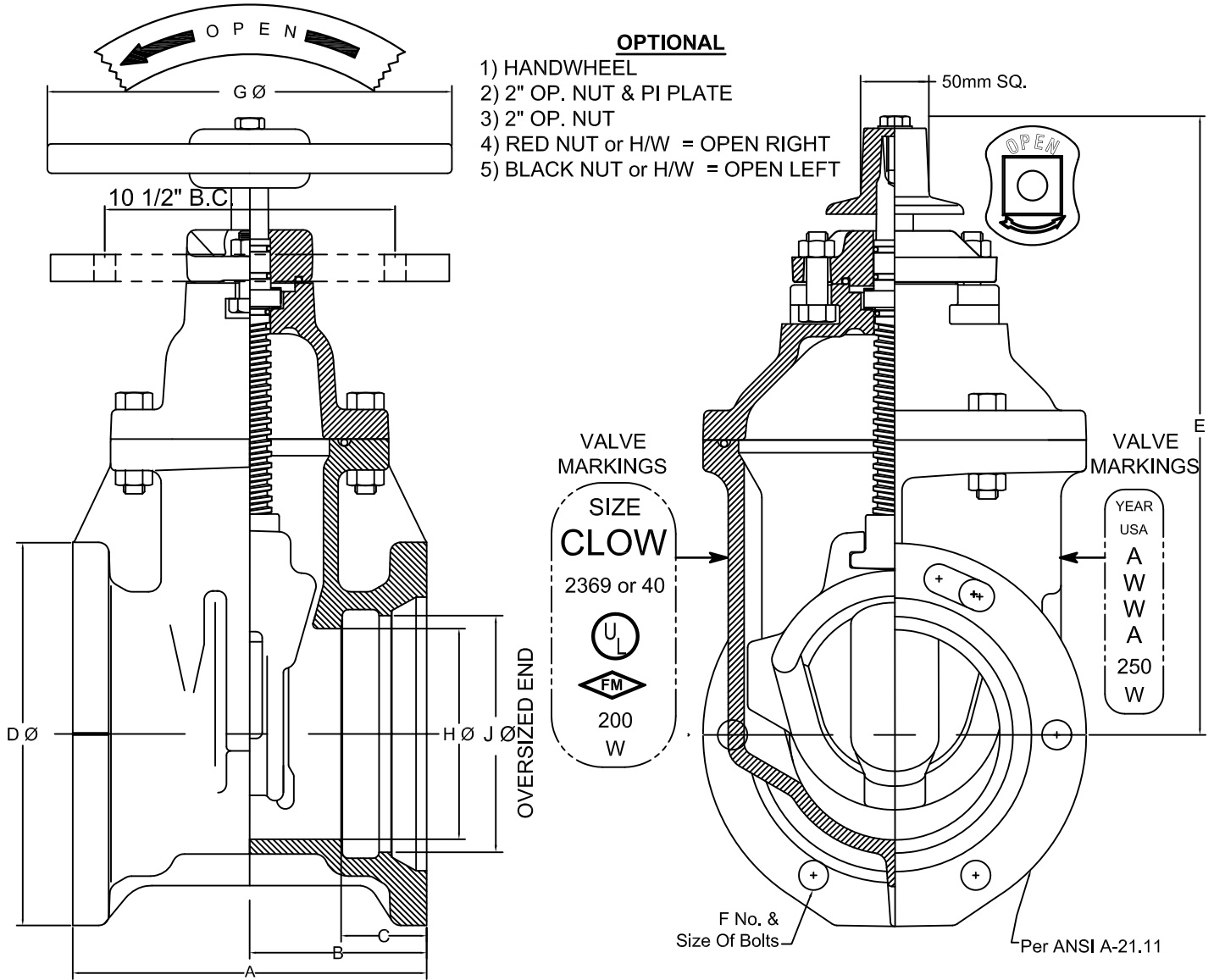

METRIC DIMENSIONS										NUMBER OF TURNS	WEIGHT W/2" NUT	WEIGHT W/ HW	WEIGHT PI PLATE
VALVE SIZE	A	B	C	D	E	F	G	H	J				
100	240	120	62.5	230	375	4 -3/4"	250	110	130	13 1/2	87 lbs	93 lbs	103 lbs
150	265	130	62.5	290	480	6 -3/4"	300	160	184	19 1/2	136 lbs	145 lbs	152 lbs
200	335	165	62.5	350	572	6 -3/4"	350	210	240	25 1/2	206 lbs	218 lbs	222 lbs
250	395	195	62.5	400	670	8 -3/4"	450	260	294	31 1/2	352 lbs	371 lbs	368 lbs
300	405	200	67	455	760	8 -3/4"	450	310	346	37 3/4	480 lbs	500 lbs	496 lbs