

CLOW CANADA

350 - 500 R/W VALVE MJ x TAP END
BEVEL GEAR GENERAL DIMENSIONS

PROJECT

OWNER

CONTRACTOR

DISTRIBUTOR

CONSULTANT

CLOW FIGURE NUMBER F6114BG

CLOW MODEL 2638 AWWA C515
REDUCED WALL DUCTILE IRON

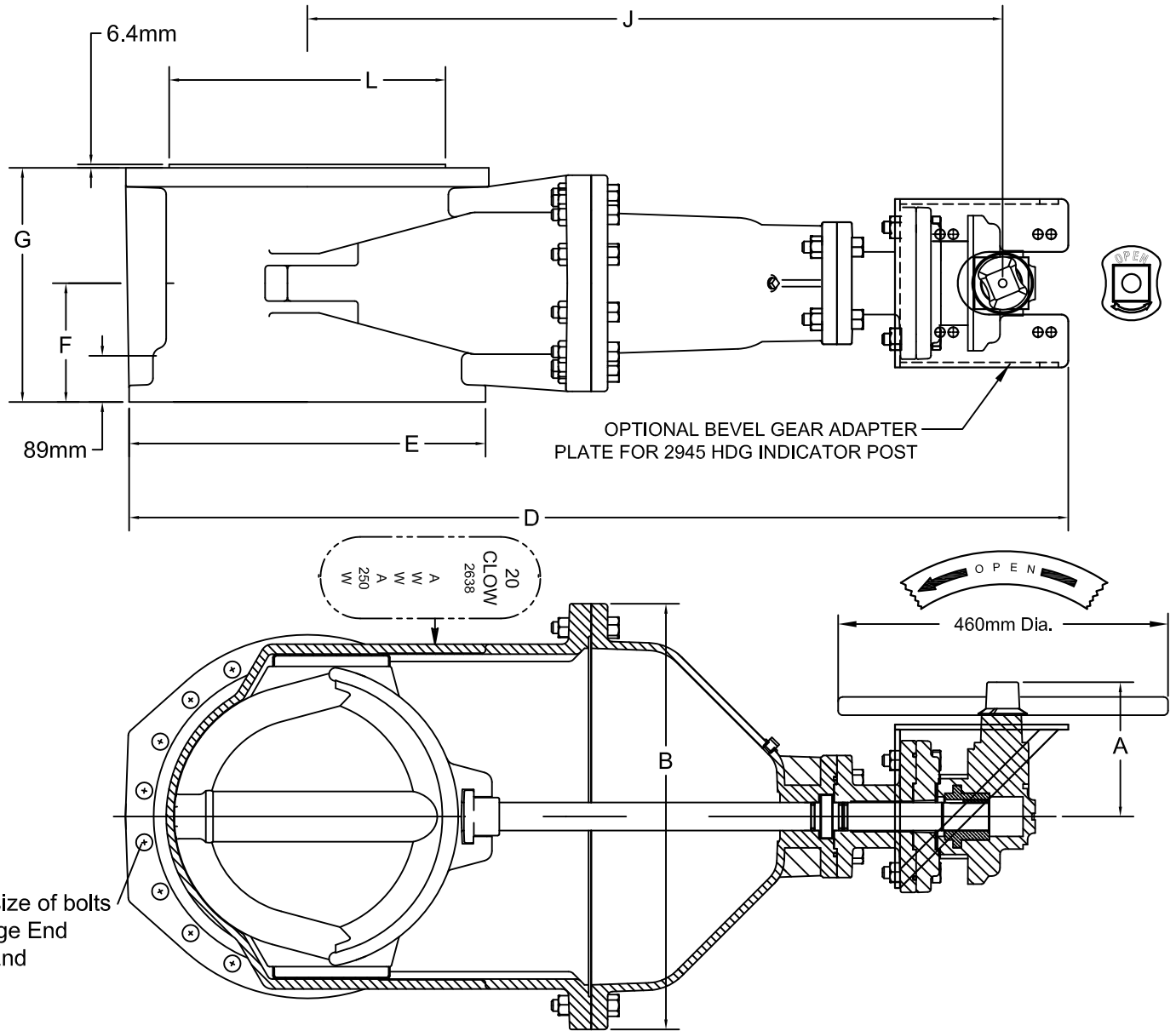

ALL DIMENSIONS IN MILLIMETERS

VALVE SIZE	A	B	C	D	E	F	G	H	J	K	L	NUMBER OF TURNS NO GEAR	NUMBER OF TURNS W/ GEAR	WEIGHT W/2" NUT	WEIGHT W/ H/W/H	WEIGHT W/BG ADAPT. PLATE
350 mm	230	675	1160	1593	515	215	425	12-1	1180	10-3/4	380	52	100	740 lbs	760 lbs	770 lbs
400 mm	230	675	1210	1590	570	215	425	16-1	1150	12-3/4	430	52	100	785 lbs	805 lbs	815 lbs
450 mm	260	820	1415	1836	630	240	465	16-1 1/8	1365	12-3/4	480		189	1325 lbs	1345 lbs	1355 lbs
500 mm	260	820	1390	1838	685	225	460	20-1 1/8	1340	14-3/4	530		189	1325 lbs	1345 lbs	1355 lbs