

CLOW CANADA

75 - 300 R/W VALVE NRS TAPP x M.J. ENDS
GENERAL DIMENSIONS

PROJECT

OWNER

CONTRACTOR

DISTRIBUTOR

CONSULTANT

CLOW FIGURE F6114

CLOW MODEL 2640 AWWA C509 FULL WALL CAST IRON

CLOW MODEL 2639 AWWA C509 FULL WALL DUCTILE IRON

OPTIONAL

- 1) HANDWHEEL
- 2) 2" OP. NUT & PI PLATE
- 3) 2" OP. NUT
- 4) RED NUT or H/W = OPEN RIGHT
- 5) BLACK NUT or H/W = OPEN LEFT

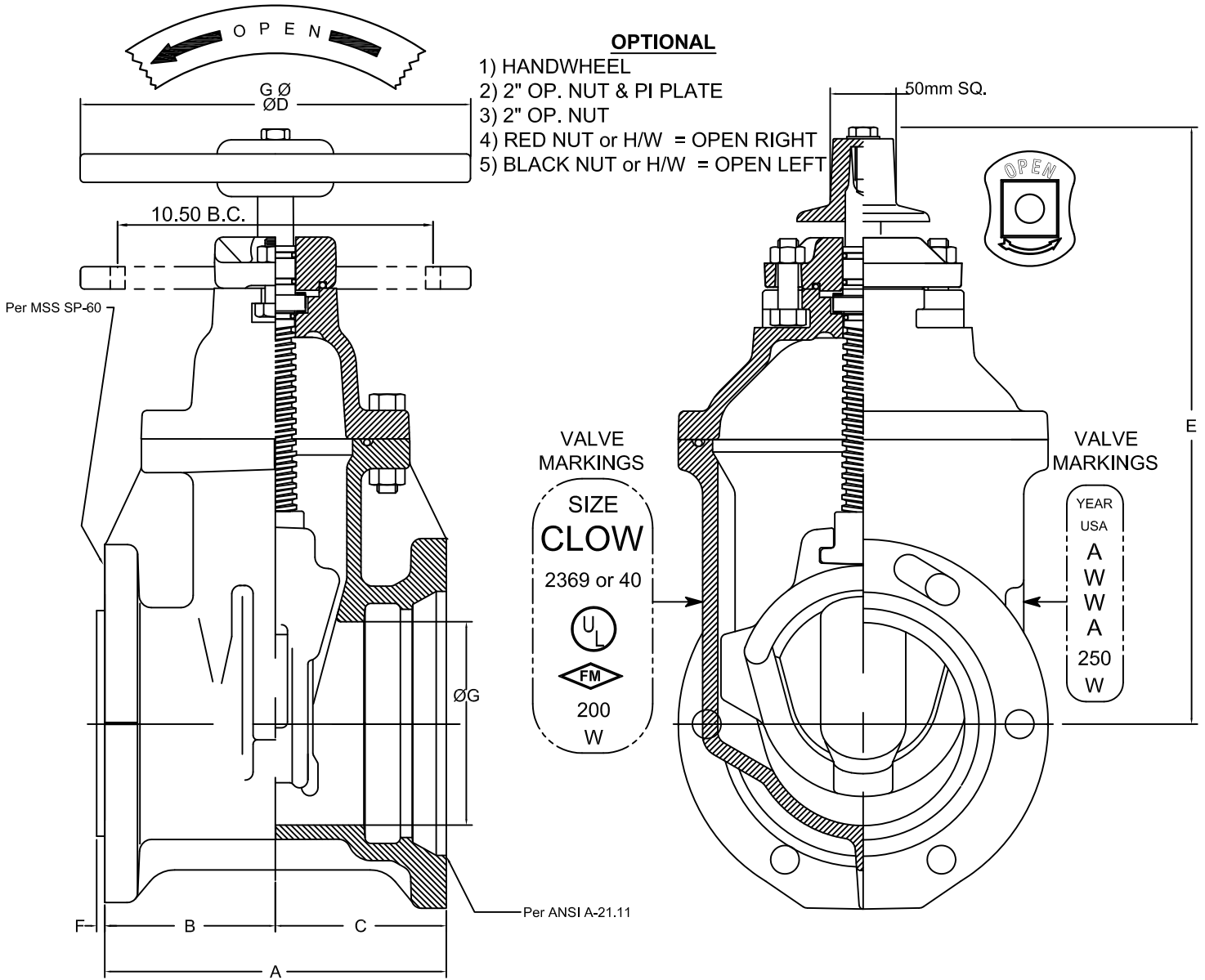

METRIC DIMENSIONS								NUMBER OF TURNS	WEIGHT W/2" NUT	WEIGHT W/ HW	WEIGHT PI PLATE
VALVE SIZE	A	B	C	D	E	F	G				
75	210	100	108	250	315	6	75	10			
100	235	115	120	250	375	6	108	13 1/2	89 lbs	95 lbs	105 lbs
150	265	133	133	300	480	7	160	19 1/2	142 lbs	151 lbs	158 lbs
200	335	145	190	350	570	7	210	25 1/2	214 lbs	226 lbs	230 lbs
250	315	165	195	450	675	7	260	31 1/2	378 lbs	397 lbs	394 lbs
300	380	175	200	450	760	7	310	37 3/4	523 lbs	542 lbs	539 lbs