

2945A INDICATOR POST

4" - 14" VALVES

WITH THERMAL BREAK

CLOW CANADA



REF. No.	DESCRIPTION	MATERIAL	QUANTITY
1	WRENCH	CAST IRON	1
2	OPERATING NUT	BRONZE	1
3	OPERATING NUT "O" RING	BUNA N	1
4	2945A INDICATOR POST CAP	CAST IRON	1
5	WINDOW GLASS	LEXAN	2
6	TARGET OPEN	CAST ALUMINUM	2
7	TARGET SHUT	CAST ALUMINUM	2
8	TARGET CARRIER ASSEMBLY		
8.1	TARGET CARRIER NUT	BRONZE	1
8.2	TARGET CARRIER PLATE	1/16" STEEL SHEET	2
8.3	TARGET RETAINER CLAMP	16GA ST. STEEL	
8.4	PAN HEAD SCREW #10-24 x 1/2"	STEEL Z.P.	
8.5	HEX NUT #10-24	STEEL Z.P.	
9	PIPE PLUG 1/2" NPT	STEEL	1
10	EYEBOLT 3/8" x 1" LG	STEEL	1
11	HEX HEAD BOLT 3/8"-16 x 1" LG	STEEL Z.P.	1
12	OPERATING STEM	1" SQUARE STEEL	1
13	BOTTOM NUT	CAST IRON	1
14	SPRING PIN 1/4" x 2 1/2" LG	STEEL	1
15	3/4"-10 SQUARE HEAD SET SCREW	STEEL	2
16	ADJUSTABLE INDICATOR POST BODY	5" DUCTILE IRON PIPE	1
17	ADJUSTABLE LOWER SECTION PIPE	4" DUCTILE IRON PIPE	1
18	BASE FLANGE	CAST IRON	1
19	5/8"-11 SQUARE HEAD SET SCREW	STEEL Z.P.	3

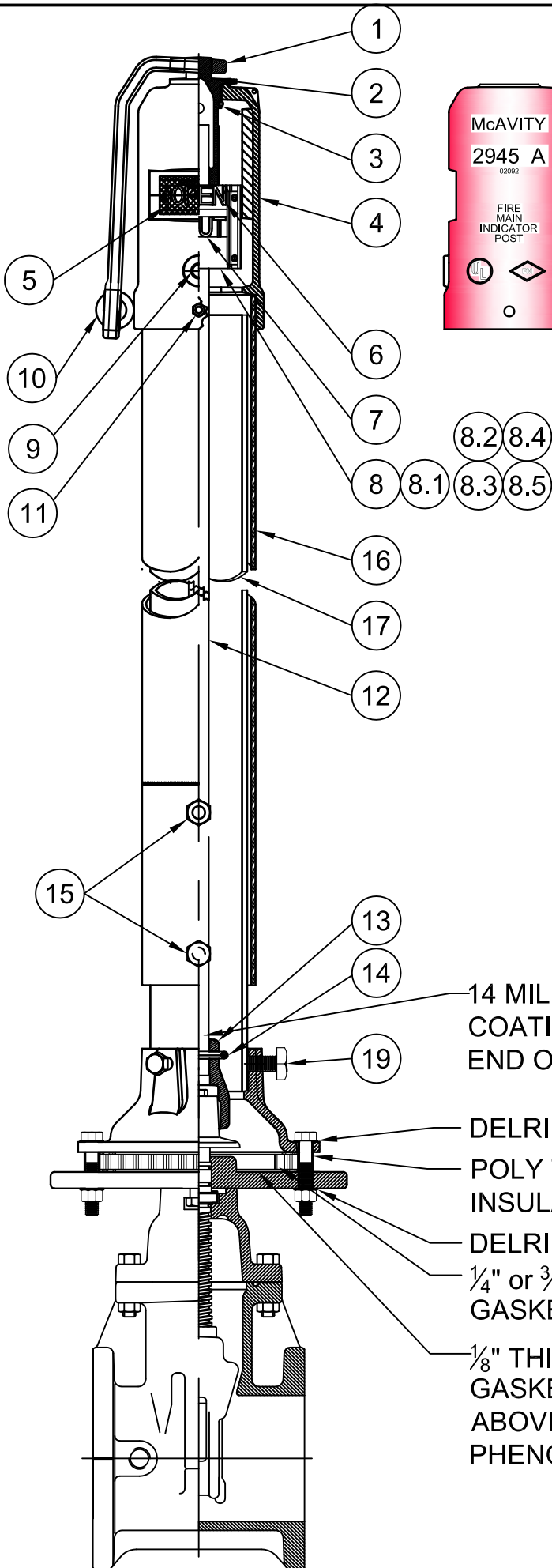

14 MIL RUBBER
COATING (BOTTOM
END OF STEM)

DELRIN WASHER

POLY TUBE BOLT
INSULATOR

DELRIN WASHER

1/4" or 3/4" THICK PHENOLIC
GASKET

1/8" THICK RED RUBBER
GASKET
ABOVE AND BELOW
PHENOLIC GASKET

2945HD INDICATOR POST

14" - 16" VALVES WITHOUT GEAR
WITH THERMAL BREAK
CLOW CANADA

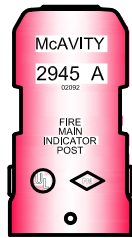
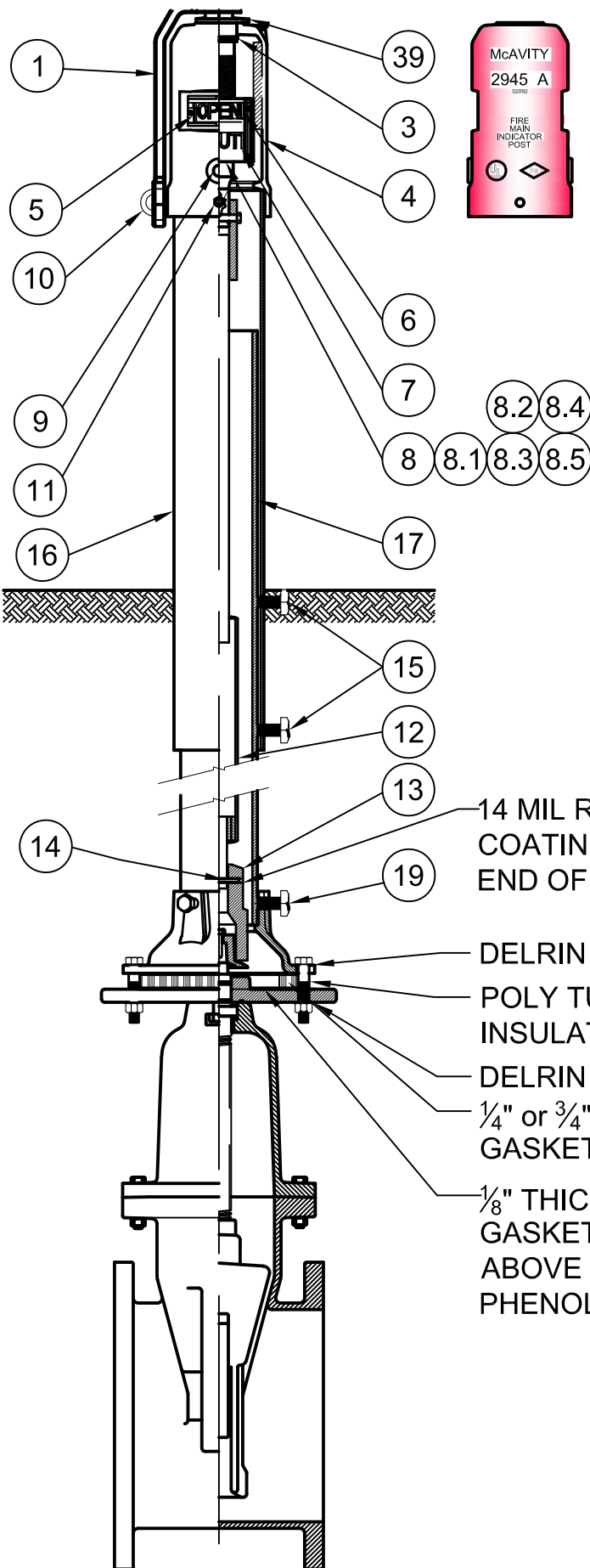

REF. No.	DESCRIPTION	MATERIAL	QUANTITY
1	WRENCH	CAST IRON	1
3	OPERATING NUT "O" RING	BUNA N	1
4	2945A INDICATOR POST CAP	CAST IRON	1
5	WINDOW GLASS	LEXAN	2
6	TARGET OPEN	CAST ALUMINUM	2
7	TARGET SHUT	CAST ALUMINUM	2
8	TARGET CARRIER ASSEMBLY		
8.1	TARGET CARRIER NUT	BRONZE	1
8.2	TARGET CARRIER PLATE	1/16" STEEL SHEET	2
8.3	TARGET RETAINER CLAMP	16GA ST. STEEL	
8.4	PAN HEAD SCREW #10-24 x 1/2"	STEEL Z.P.	
8.5	HEX NUT #10-24	STEEL Z.P.	
9	PIPE PLUG 1/2" NPT	STEEL	1
10	EYEBOLT 3/8" x 1" LG	STEEL	1
11	HEX HEAD BOLT 3/8"-16 x 1" LG	STEEL Z.P.	1
12	OPERATING PIPE STEM	STEEL	1
13	BOTTOM NUT	CAST IRON	1
14	SPRING PIN 1/4" x 2 1/2" LG	STEEL	1
15	3/4"-10 SQUARE HEAD SET SCREW	STEEL	2
16	ADJUSTABLE INDICATOR POST BODY	5" DUCTILE IRON PIPE	1
17	ADJUSTABLE LOWER SECTION PIPE	4" DUCTILE IRON PIPE	1
18	BASE FLANGE	CAST IRON	1
19	5/8"-11 SQUARE HEAD SET SCREW	STEEL	3
24	HEAVY DUTY STEM COUPLING	DUCTILE IRON	1
25	3/8" x 3" LG HEX BOLT AND NUT	STEEL Z.P.	1
38	HEAVY DUTY BOTTOM NUT	DUCTILE IRON	1
39	2945A HEAVY DUTY OPERATING NUT	BRONZE	1

14 MIL RUBBER COATING (BOTTOM END OF STEM)

DELTRIN WASHER
POLY TUBE BOLT INSULATOR
DELTRIN WASHER
1/4" or 3/4" THICK PHENOLIC GASKET
1/8" THICK RED RUBBER GASKET ABOVE AND BELOW PHENOLIC GASKET

REF. No.	DESCRIPTION	MATERIAL	QUANTITY
1	LOCKING WRENCH	CAST IRON	1
2	2945HDG OPERATING NUT	BRONZE	1
3	RETAINER "O" RING	BUNA N	1
4	2945HDG INDICATOR POST CAP	CAST IRON	1
5	WINDOW GLASS	LEXAN	2
6	TARGET "OPEN"	CAST ALUMINUM	2
7	TARGET "SHUT"	CAST ALUMINUM	2
8	2945HDG TARGET CARRIER ASSEMBLY		
8A	TARGET CARRIER NUT	BRONZE	1
8B	2945HDG TARGET CARRIER PLATE	1/16" STEEL SHEET	2
8C	2945HDG TARGET RETAINER CLAMP	16GA ST. STEEL	4
8D	PAN HEAD SCREW #10-24 x 1/2"	STEEL Z.P.	8
8E	HEX NUT #10-24	STEEL Z.P.	8
9	EYEBOLT 3/8" x 1" LG	STEEL	1
10	HEX HEAD BOLT 3/8"-16 x 1" LG	STEEL Z.P.	2
11	2945HDG OPERATING STEM	STEEL	1
12	H.D.BOTTOM NUT (COUPLE STEM TO VALVE)	CAST IRON	1
13	SPRING PIN 1/4" x 2 1/2" LG	STEEL	1
14	3/4"-10 SQUARE HEAD SET SCREW	STEEL	2
15	ADJUSTABLE INDICATOR POST BODY	5" D.I. PIPE	1
16	ADJUSTABLE LOWER SECTION PIPE	4" D.I. PIPE	1
17	BASE FLANGE	CAST IRON	1
18	HEX HEAD BOLT 5/8"-11 x 2" LG	STEEL Z.P.	3
19	HEX HEAD BOLT 5/8"-11 x 3 1/4" LG	STEEL Z.P.	4
20	HEX NUT 5/8-11	STEEL Z.P.	4
21	3/8" x 3 HEX BOLT	STEEL Z.P.	1
22	HEX NUT 3/8-16	STEEL Z.P.	1
23	1 1/4" SQ. STEM COUPLING	DUCTILE IRON	1

2945HDG INDICATOR POST WITH THERMAL BREAK

14" - 24" VALVES W/BEVEL GEAR CLOW CANADA

