

# FIGURE No. 7058

Item	Description	# Req'd	Material
R-1	Hex. Head Bolt	1	Stainless Steel ASTM F593C
R-2	Flat Washer	1	Commercial Steel
R-3	Operating Nut	1	Cast Iron ASTM A-126 Class B
R-3	Hand Wheel	1	Cast Iron ASTM A-126 Class B
R-4	Stuffing Box Bolts	2	Stainless Steel ASTM F593C
R-5	Hex. Nuts	2	Stainless Steel ASTM F594
R-6	Stuffing Box	1	Ductile Iron ASTM A536 Grade 70-50-5
R-7	'O' Ring (Stem)	3	BUNA-N
R-8	'O' Ring (St. Box)	1	BUNA N
R-9	Thrust Washer	1	2" & 2.5" DELRIN
R-9		2	3" & 12"
R-10	Stem	1	Bronze ASTM B 584, C86700
R-11	Hex. Head Bolts		Stainless Steel
R-12	Hex. Nuts		Stainless Steel
R-13	Cover	1	Ductile Iron
R-14	Stem Nut	1	Bronze ASTM B-584\C83600
R-15	'O'Ring (cover)	1	BUNA-N
R-16	Wedge Disc	1	3"-4": Gray Iron, 6"-12": Ductile EPDM Resilient Molded Wedge
R-17	Body	1	Ductile Iron
R-18	(Optional Post Adaptor Plate)	1	Cast Iron ASTM A126 Class B



(2 1/2" - 8")

**RESILIENT SEAT GATE VALVE  
WITH CLASS 250 END FLANGES  
SIZES 2.5" - 12"  
DUCTILE IRON MODEL KS-300**

**KENNEDY VALVE**

Generic Valve available in 10" - 12"

- Coating: Heat Fused Epoxy
- Bolts: Strength to meet ASTM A307
- Flanges: ASME B16.1 CLASS 250

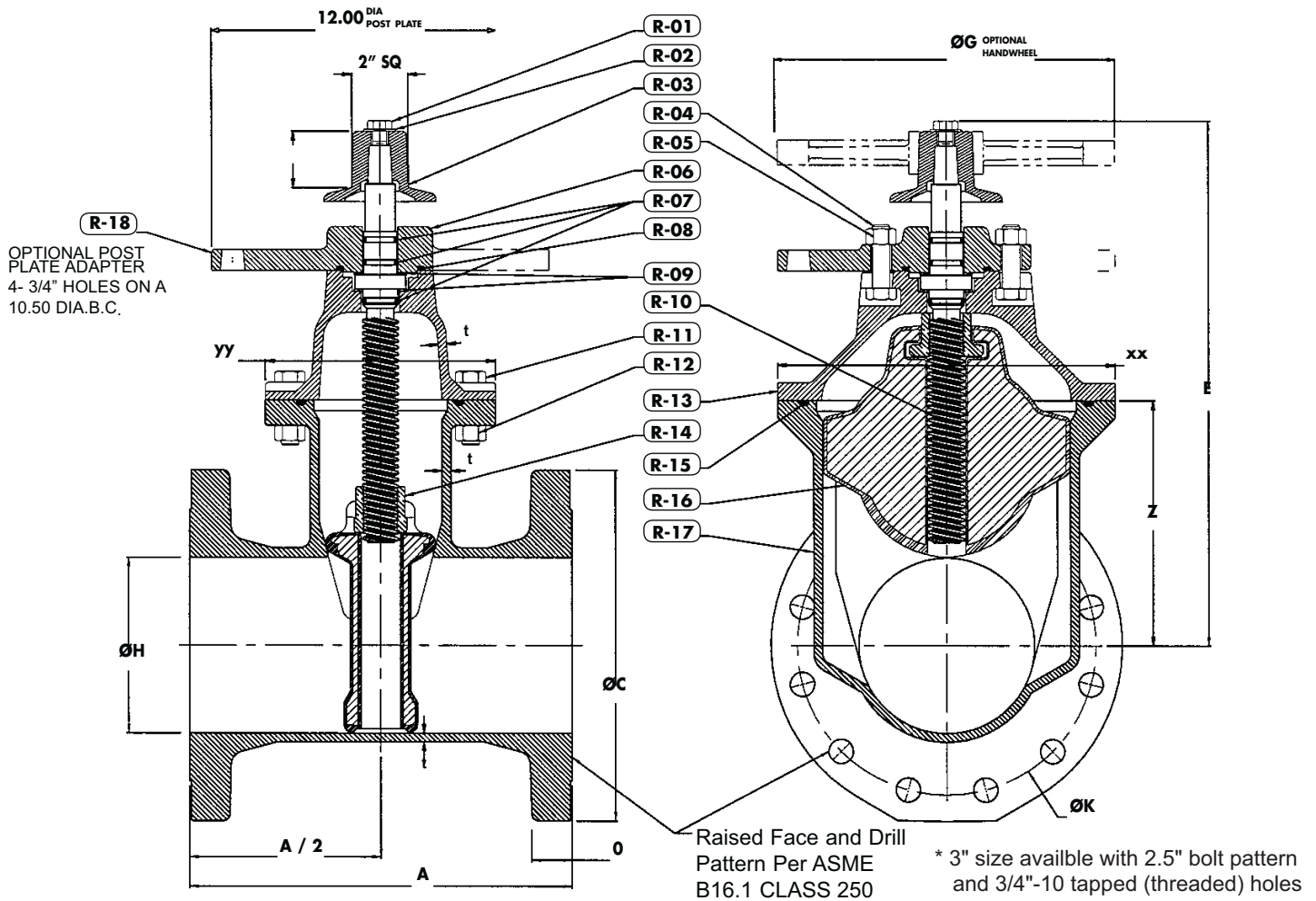

REFERENCE DIMENSIONS			
Nominal Size In's	xx	yy	z
* 2.5	7.50	6.75	5.00
3	7.50	6.75	5.00
4	9.50	7.00	6.00
6	12.00	8.00	8.75
8	14.88	9.00	10.38
10	18.38	10.75	12.13
12	20.81	11.25	14.13

Nominal Size (inch)	Clear Dia H	No. of Turns to open	Valve Dimensions			Flanges & Flange Drilling						
			A	E	H'Wheel O.D. GØ	Flange O.D. CØ	Flange Thick O	B.C. Ø K	Size of Bolts FØ	No. of Bolts F	Approx Weight (lbs)	
* 2.5	3.00"	5	8.36	-	-	8.25	1.13	5.88	3/4	8	78	
3	3.00"	10	8.63	-	-	8.25	1.13	6.63	3/4	8	78	
4	4.25"	13	11.75	14.75"	10.00"	10.00	1.25	7.88	3/4	8	99	
6	6.25"	19	13.63	19.00"	12.00"	12.50	1.44	10.62	3/4	12	166	
8	8.25"	25	14.13	22.50"	14.00"	15.00	1.63	13.00	7/8	12	253	
10	10.25"	31	14.31	26.50"	18.00"	17.50	1.88	15.25	1	16	415	
12	12.25"	37	15.37	30.00"	18.00"	20.50	2.00	17.75	1 1/8	16	532	