

	PATT OR DIE No.	FINISH	UNLESS OTHERWISE SPECIFIED DECIMAL DIM'S IN 2 PLACES + or -.02 DIM'S IN 3 PLACES + or -.01 FRACTION DIM'S UNDER 6" + or - DIM'S OVER 6" + or -
LETTER CHANGE	MATERIAL	WEIGHT	
REF. Nos.			

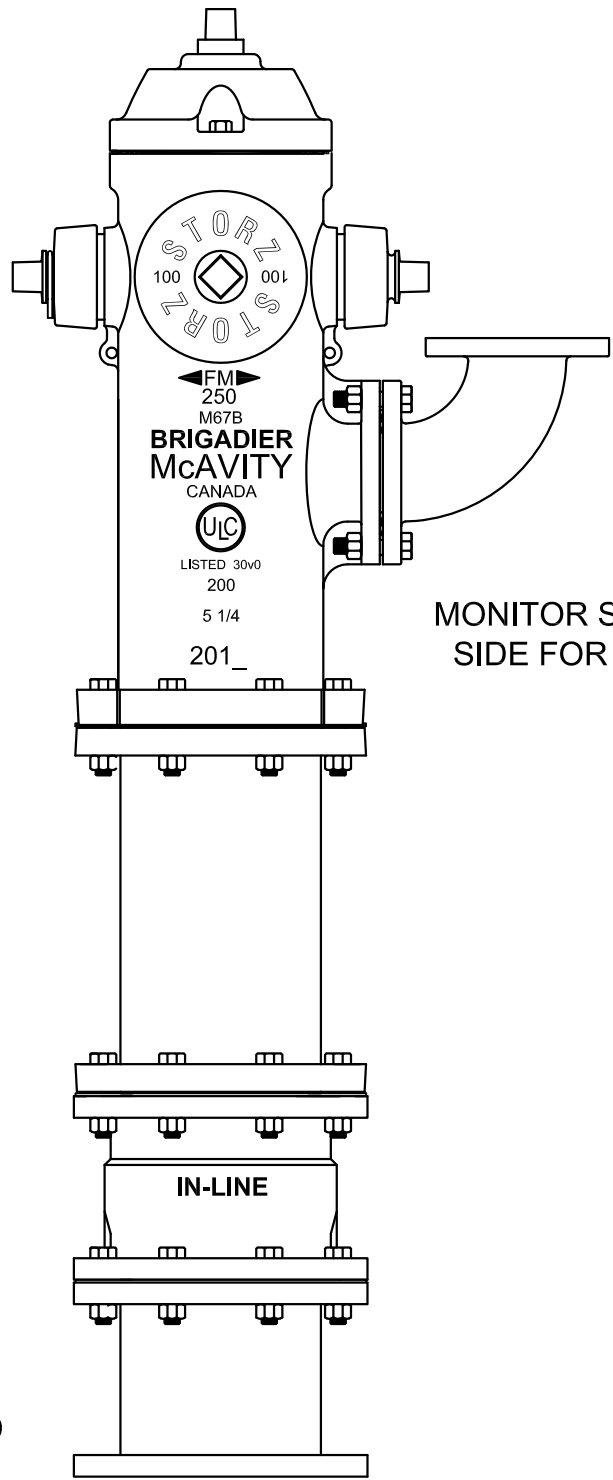

MONITOR SHOWN AT
SIDE FOR CLARITY

SPECIFY INLET REQUIRED
M.J., FLANGED, PUSH-ON
ELBOWS OR ON-LINE CHAMBER

DRAWN <i>L.G. McKay</i>	CHECKED	EXAMINED	NOTED	APPROVED
----------------------------	---------	----------	-------	----------

M67B 2 HOSE
STORZ PUMPER + MONITOR
WITH 6" IN-LINE CHAMBER

CLOW CANADA

M67B - 050

SCALE NOT TO SCALE DATE SEPT. / 2010