

	PATT OR DIE No.	FINISH	UNLESS OTHERWISE SPECIFIED DECIMAL DIM'S IN 2 PLACES + or - .02 DIM'S IN 3 PLACES + or - .01  FRACTION DIM'S UNDER 6" + or - DIM'S OVER 6" + or -
LETTER CHANGE	MATERIAL	WEIGHT	
REF. Nos.			

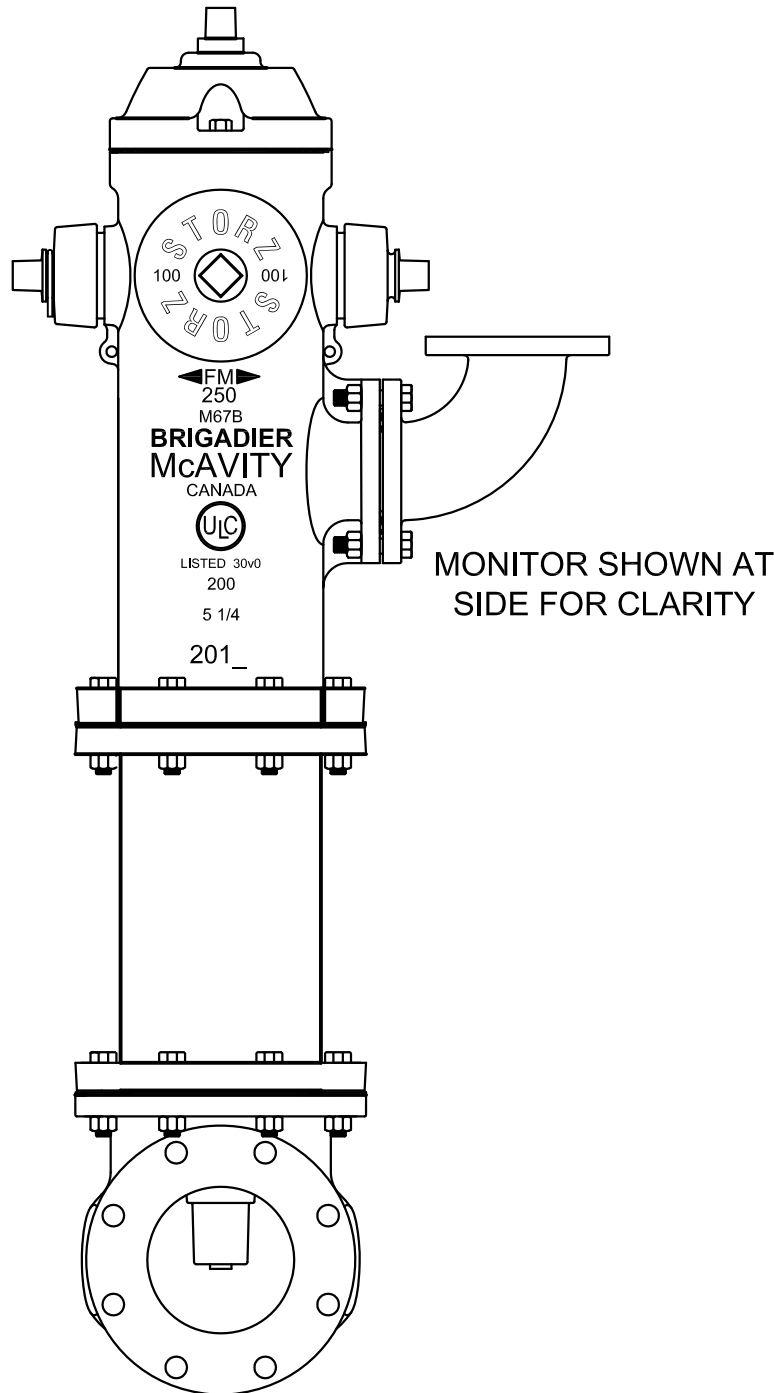

DRAWN <i>L.G. McKAY</i>	CHECKED	EXAMINED	NOTED	APPROVED
----------------------------	---------	----------	-------	----------

M67B 2 HOSE  
STORZ PUMPER + MONITOR  
WITH 6" FLANGED ELBOW

**CLOW CANADA**

SCALE NOT TO SCALE DATE SEPT. / 2010

M67B - 016