

		PATT OR DIE No.	FINISH	UNLESS OTHERWISE SPECIFIED DECIMAL DIM'S IN 2 PLACES + or - .02 DIM'S IN 3 PLACES + or - .01 FRACTION DIM'S UNDER 6" + or - DIM'S OVER 6" + or -
LETTER CHANGE	MATERIAL	WEIGHT		

REF. Nos.

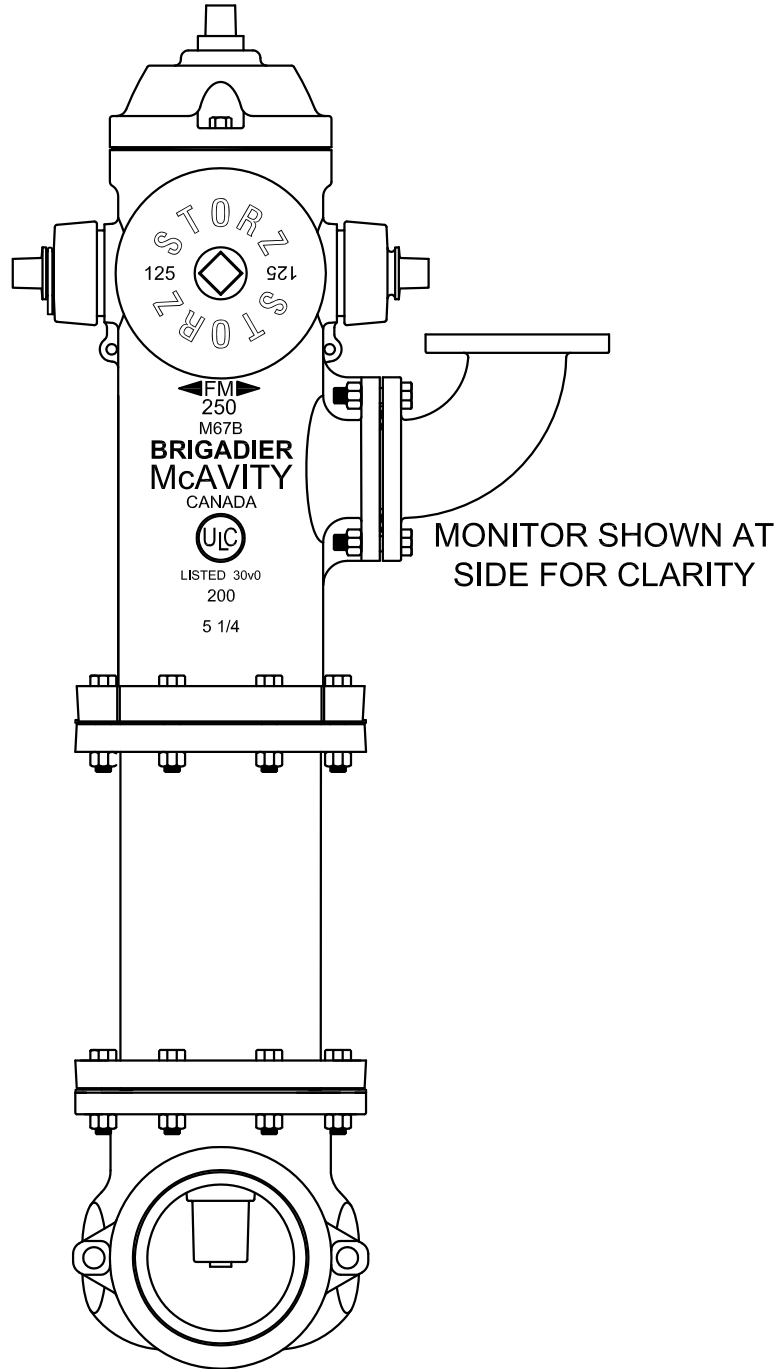

DRAWN <i>L.G. McKAY</i>	CHECKED	EXAMINED	NOTED	APPROVED
----------------------------	---------	----------	-------	----------

M67B 2 HOSE 5" (125mm)
STORZ PUMPER + MONITOR
WITH 6" PUSH-ON ELBOW

CLOW CANADA

M67B - 027

SCALE NOT TO SCALE DATE SEPT. / 2010