

		PATT OR DIE No.	FINISH	UNLESS OTHERWISE SPECIFIED DECIMAL DIM'S IN 2 PLACES + or - .02 DIM'S IN 3 PLACES + or - .01
LETTER CHANGE	MATERIAL	WEIGHT		

REF. Nos.

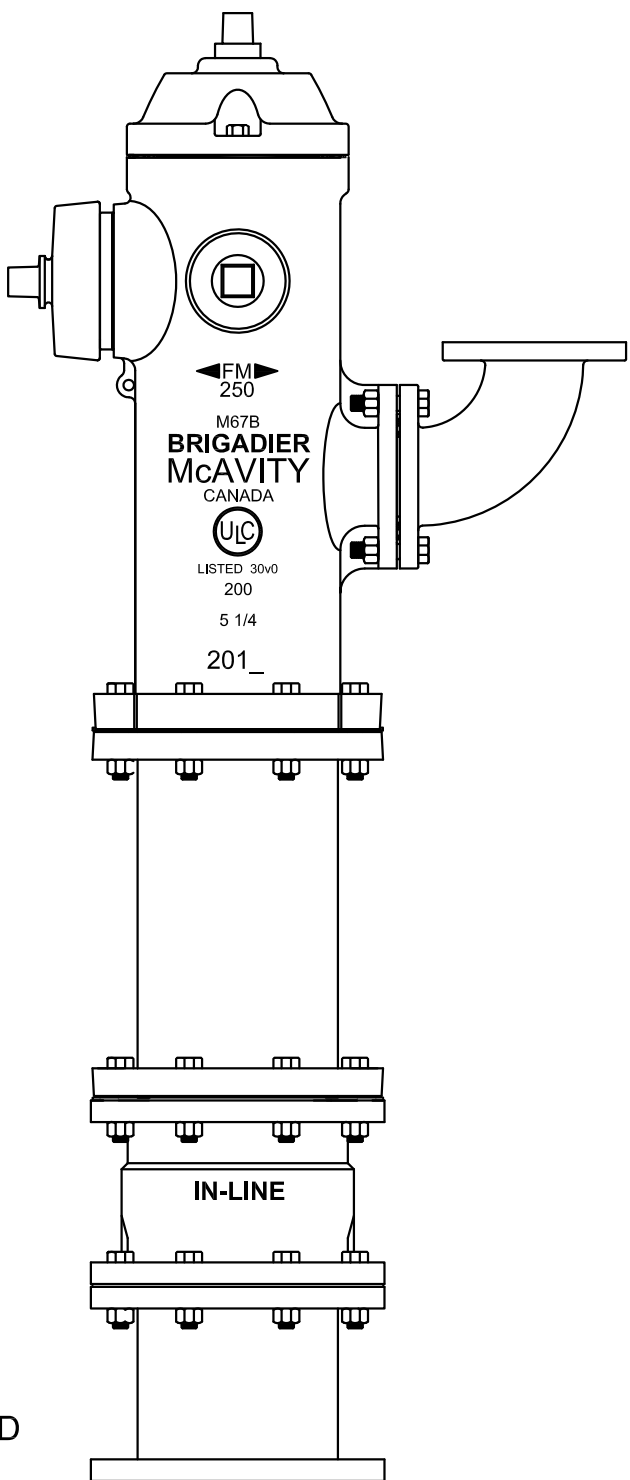

SPECIFY INLET REQUIRED  
M.J., FLANGED, PUSH-ON  
ELBOWS OR ON-LINE CHAMBER

DRAWN <i>L.G. McKAY</i>	CHECKED	EXAMINED	NOTED	APPROVED
----------------------------	---------	----------	-------	----------

M67B 2 HOSE 1 PUMPER + MONITOR  
WITH 6" IN-LINE CHAMBER

**CLOW CANADA**

M67B - 049

SCALE NOT TO SCALE DATE SEPT. / 2010