

Parts List

Item	Description	Required	Material	ASTM	
1	Cap Nut	1	Steel	A307	GR B Cad. Plated
2	Operating Nut	1	Cast Iron	A126	CL B
3	Cap Screw	2	Steel	A307	GR B Cad. Plated
4	Thrust Nut	1	Bronze	B132	Aloy A
5	Yoke	1	Cast Iron	A126	CL B
6	Stem	1	Bronze	B138	Aloy A (1/2 hard)
7	Cap Screw	2	Steel	A307	GR B Cad. Plated
8	Stem Cap	1	Cast Iron	A126	CL B
9	Plug	1	Cast Iron	A126	CL B
10	Frame	1	Cast Iron	A126	CL B
11	Cap Screw	4	Steel	A307	GR B Cad. Plated

A25612RB Mud Valve, Rising Stem

Size	4	6	8	10	12	14	16	18
A	9	11	13 1/2	16	19	-	23 1/2	25
B	1 5/16	1	1 1/8	1 3/16	1 1/4	-	1 7/16	1 9/16
C	10 3/4	12 7/16	14 1/4	16 1/4	18 3/16	-	21 1/4	23 1/16
D	1 7/8	3 1/8	4 5/16	5 3/8	6 9/16	-	8 7/16	8 7/16
E	3/4	7/8	7/8	1	1	-	1 1/8	1 1/4
F	6	6	8	8	10	-	14	14
G	7 1/2	9 1/2	11 3/4	14 1/4	17	-	21 1/4	22 3/4

E - Diameter of Holes
 F - Number of Holes Used
 G - Bolt Circle Diameter

**3 STD ACME THDS PER INCH
 OPEN LEFT**

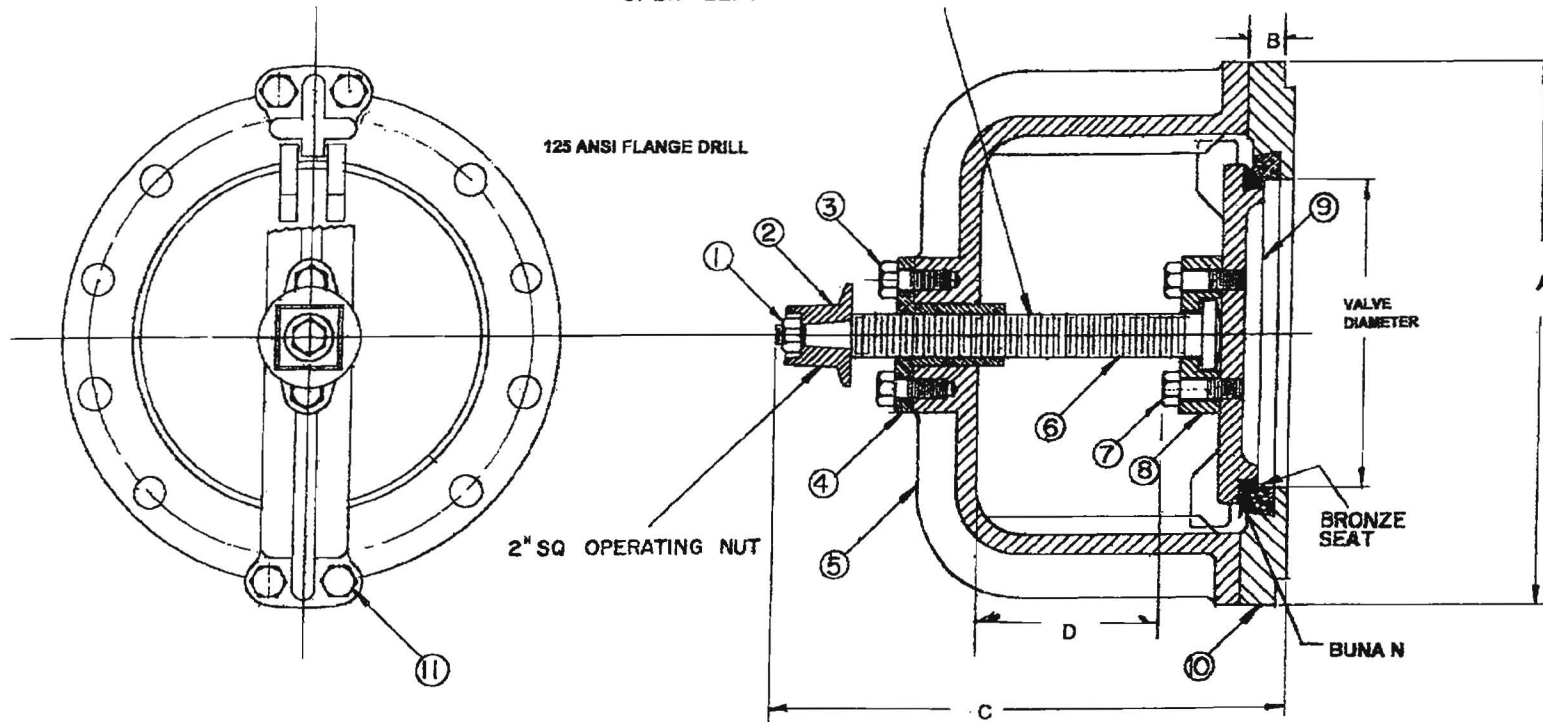

MATERIAL:	MUD VALVE—RISING STEM
DATE:	
TROY VALVE Troy, PA	NO. A25612RB