

Parts List

Item	Description	Required	Material	ASTM	
1	Body	1	Cast Iron	A126	CLB
2	Seat Ring	1	Bronze	B62	
3	Lift Handle	1	Steel	A107	GR.1115
4	Disc w/Br Disc Ring	1	Cast Iron	A126	CLB
5	Right Hand Wedge	1	Cast Iron	A126	CLB
6	Wedge Bolt	2	Steel		ASA B18.2
7	Hinge Bolt	1	Bronze	B62	
8	Hinge Bolt Nut	1	Bronze	B62	
9	Set Screw	1	Steel		Plated

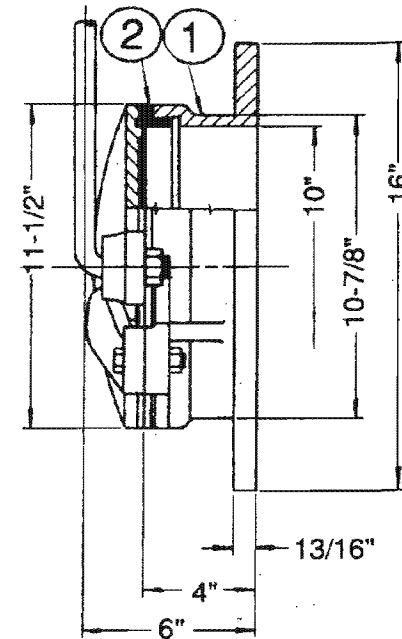

FURNISHED WITH TWO FOOT LIFT
HANDLE AND CATCH (A-25215)

LONGER LIFT HANDLE
FURNISHED WHEN SPECIFIED

ORTON 6-14-65
Z.F.R. 6-8-66
R.L.R. 6-8-66
Z.F.R. 6-8-66

REPLACES DWG. NO. E-3352 BY E.M.M. 6-19-40

MATERIAL:	10" SHEAR GATE, FLANGE END, SINGLE WEDGE
DATE:	
TROY VALVE Troy, PA	
NO. A-2520-6/E-3352	