

20 - 1-3/8" HOLES  
ON 29-1/2" B.C. STRADDLE  
VERT. C

FURNISHED WITH TWO FOOT LIFT  
HANDLE AND CATCH (A-25215)  
LONGER LIFT HANDLE  
FURNISHED WHEN SPECIFIED

ELLIS 7-9-65  
ORTON 6-8-66  
R.L.R. 6-8-66  
Z.F.R. 6-8-66

Parts List

Item	Description	Required	Material	ASTM	
1	Body	1	Cast Iron	A126	CLB
2	Seat Ring	1	Bronze	B62	
3	Lift Handle	1	Steel	A107	GR.1115
4	Disc w/Br Disc Ring	1	Cast Iron	A126	CLB
5	Right Hand Wedge	1	Cast Iron	A126	CLB
6	Wedge Bolt	2	Steel		ASA B18.2
7	Hinge Bolt	1	Bronze	B62	
8	Hinge Bolt Nut	1	Bronze	B62	
9	Set Screw	1	Steel		Plated

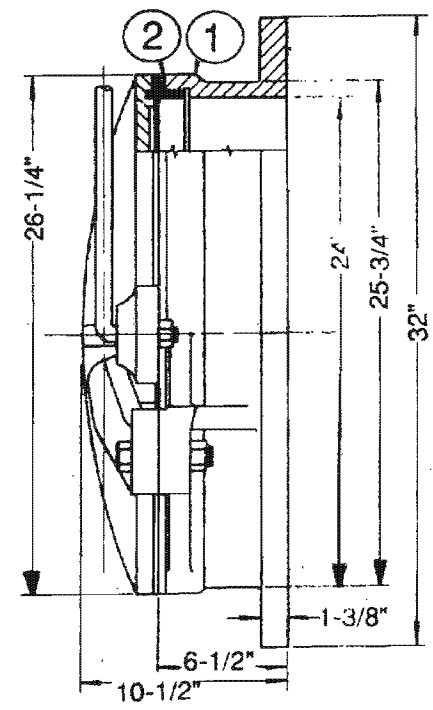

REPLACES DWG. NO. E-3311 BY J.D.K. 7-26-56

MATERIAL:	<b>24" SHEAR GATE, FLANGE END, SINGLE WEDGE</b>
DATE:	
<b>TROY VALVE</b> Troy, PA	
NO. <b>A-2520-6/E-3311</b>	