

360C RESTRAINER ASSEMBLY INSTRUCTIONS

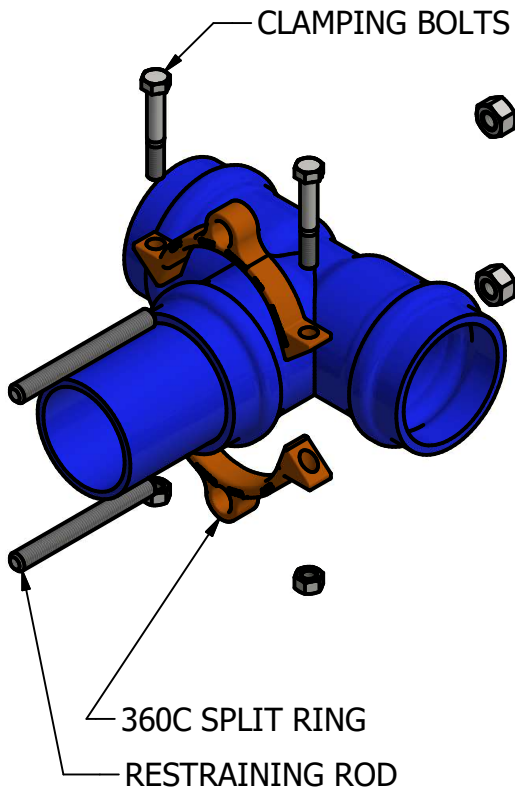

1. Install pipe into the fitting per the pipe manufacturer's instructions. Place the 360C split ring behind the fittings gasket races clamping the halves together. Insert the restraining rods into each 360C split ring placing a nut on each rod behind the ring.



2. Use the restraining rod as a guide and position the 300C split clamp on the pipe. Place hex head clamp bolts through clamp ears insuring bolt end threads are exposed. **DO NOT TIGHTEN CLAMP BOLTS, LEAVE LOOSE.**

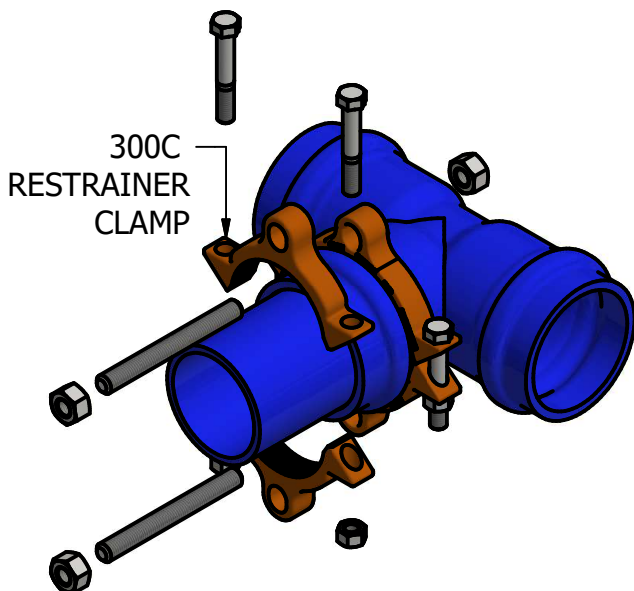

3. Align the restraining rods and insure equal threads are beyond the 360C ring and the 300C clamp. Tighten the clamping bolts and nuts insuring equal gaps exist between the two halves. Torque clamping bolts to the following torque requirements:

- 4" - 6" clamps (100 ft-lbs)
- 8" clamps (150 ft-lbs)
- 10" - 12" clamps (200 ft-lbs)

4. Complete the installation by tightening the restraining rod nuts until snug.

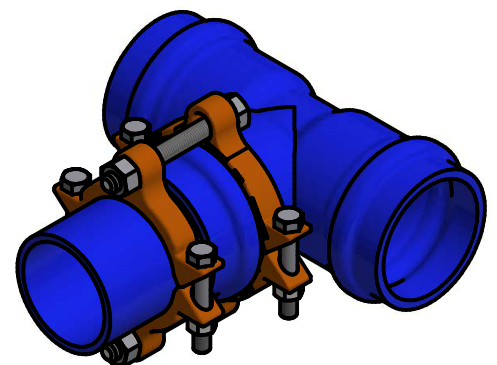

CLOW CANADA