



**14"- 48" RESILIENT SEAT GATE VALVE  
WITH ROTORK/EXEECO GEARING**

**O & M MANUAL**

**TABLE OF CONTENTS**

Page 1	General Info/Installation Instructions
2 – 3	Operation/Inspection & Maintenance
4	Records
5	RW GV 14"-20" Bevel Gear/ Parts List Recommended Spare Parts
6	RW GV 14"-20" Spur Gear/ Parts List Recommended Spare Parts
7	RW GV 24" Bevel Gear/Parts List Recommended Spare Parts
8	RW GV 24" Spur Gear/Parts List Recommended Spare Parts
9	14" – 24" RW Geared Valve Disassembly
10-11	RW GV 30" – 48" Bevel Gear Assembly
12	30" – 48" Bevel Gear/Parts List Recommended Spare Parts
13-14	RW GV 30" – 48" Spur Gear Assembly
15	30" – 48" Spur Gear/ Parts List Recommended Spare Parts
16	30" – 48" RW GV Disassembly
17	Troubleshooting
18 – 22	Rotork/Exeeco Bevel Gear
23 – 27	Rotork/Exeeco Spur Gear



Clow Valve Co.

902 South 2nd Street  
Oskaloosa, IA 52577

Telephone: 641 673-8611  
Fax: 641 673-8269

## INSTALLATION, OPERATION AND MAINTENANCE MANUAL

### RESILIENT SEAT GATE VALVE

**GENERAL;** *Inspect all valves at time of delivery for shipping damage and to confirm compliance with specifications. Valves are completely tested per the appropriate standards and specifications by the manufacturer. The valves should be stored in such a manner to protect them from weather and blowing dirt and debris. In cold climates, if water is allowed to freeze in the valve, severe damage to the valve components could result. Any packaging should be replaced if removed for inspection. Proper slinging and handling methods should be used when moving valves. Do not place slings or other devices around operating stem or through the valve port opening.*

#### **I. Installation**

1. *Check that valve end joints are clean. Again check for damage to the valve. Open and close valve to insure proper operation. Close wedge before placing valve in trench or line.*
2. *Handle valve carefully. Do not drop into position. Do not sling through the port opening.*
3. *Prepare pipe ends according to manufacturer's instructions. Install valve per proper methods according to end joint type. All piping should be properly supported to avoid line stress on the valve. Do not use the valve as a jack to force a pipeline into position.*
4. *A valve box or vault should be provided for each valve used in buried service application. These should be installed such that no load is transferred to the valve.*
5. *Before pressurization of the pipeline and valve, all pressure containing bolting (cover, follower plate, end connection) should be inspected for adequate tightness (usually 90 ft. lb.).*
6. *Buried valves should be pressurized before backfilling.*
7. *With valve in open position, the entire system should be thoroughly flushed to clean the system. Debris in the valve could prevent valve from closing or possibly damage the resilient material on the wedge.*

8. Upon completion of the installation, gate valve location, size, type, date of installation, number of turns to open, direction of opening, and any other special information should be entered on permanent records.

## II. Operation

1. Do not operate valves in systems that exceed the rated working pressure of the valve, (14"-48" 250 psi).

System should be completely flushed before valve is operated in normal cycle.

2. The RW valve opens and closes by turning the main valve stem with an operating nut or handwheel. The valve closes by compressing the resilient material bonded to the wedge against the valve body. As the material is being compressed (at end of closing cycle) torque requirements will approach maximum. Opening the valve requires significantly less torque.
3. If the valve should fail to seal after necessary number of turns, open the valve four or five times and reseal.

### **Emergency Operation;**

**Turn the handwheel of operating nut faster in the desired direction.**

## III. Inspection and Maintenance

1. Frequency of inspection should be based on frequency of operation. Semi annual inspections are minimum recommended. Valves should not be disassembled unless a breakdown has occurred.
2. During inspection, the valve should be opened and closed with pressure in the pipeline. The valve should function freely with no binding or vibration. Count the number of turns to full closed, this will reveal an obstruction if correct number of turns are not achieved. See table;

---

### TURNS TO OPEN

14" - 52	with spur gear - 104	with bevel gear - 104
16" - 52	with spur gear - 104	with bevel gear - 104
18" - 64	with spur gear - 192	with bevel gear - 192
20" - 64	with spur gear - 192	with bevel gear - 192
24" - 76	with spur gear - 228	with bevel gear - 228
30" - 98	with spur gear - 588	with bevel gear - 588
36" - 114	with spur gear - 684	with bevel gear - 684
42" - 100	with spur gear - 800	with bevel gear - 800
48" - 100	with spur gear - 800	with bevel gear - 800



3. *All gaskets and joints should be checked for leakage and tightness.*
4. *With the valve closed and pressure against the disc, a check for leakage is possible by "listening" to the valve for flow. A stethoscope will help in this procedure.*
5. *Attached actuators should be inspected per manufacturer's recommendations provided with those units.*
6. *OS&Y valves should have the exposed stem lubricated at each inspection. Check stuffing box bolts for tightness.*
7. *A permanent inspection record should be kept for each valve.*

**RECORDS**

1. Trouble can be anticipated with a good Inspection Program. Such a program can not exist without good records. Poor records are worse than none.
2. A printed 5 x 8 record card for each valve and hydrant in the system is most convenient.
  - a. Identification of each valve and hydrant is essential. Setting up a numbering system is one of the first steps to take. A reasonably simple method is to assign a number to each street intersection, then identify each valve of hydrant numerically or alphabetically between intersection numbers.  
For instance; I9-I10, would be the number of second valve from street intersection number 9 in going toward street number 10.  
  
Another convenient device is to assign only odd numbers to existing hydrants. When hydrants are added later they can be giving numbers which will fit in the numerical sequence.
  - b. Location should be recorded first. Measurements must be made from property lines or street center lines – not power poles fence lines - or the like.

**VALVE RECORD**

No. \_\_\_\_\_

Location \_\_\_\_\_ FT. \_\_\_\_\_ of \_\_\_\_\_ Prop. Line of \_\_\_\_\_  
 And \_\_\_\_\_ FT. \_\_\_\_\_ of \_\_\_\_\_ Prop. Line of \_\_\_\_\_  
 Size \_\_\_\_\_ Make \_\_\_\_\_ Type \_\_\_\_\_ Gearing \_\_\_\_\_ Bypass \_\_\_\_\_  
 Opens \_\_\_\_\_ Turns to Operate \_\_\_\_\_ Depth of Nut \_\_\_\_\_  
 Remarks \_\_\_\_\_  
 \_\_\_\_\_  
 \_\_\_\_\_

**Maintenance & Inspection Record**

Date	Work Done	O.K.	By	Date	Work Done	O.K.	By

Complies with  
AWWA C515

14"-20" RW VALVE  
BEVEL GEAR MATERIAL LIST  
**CLOW VALVE COMPANY**

MODEL 2638

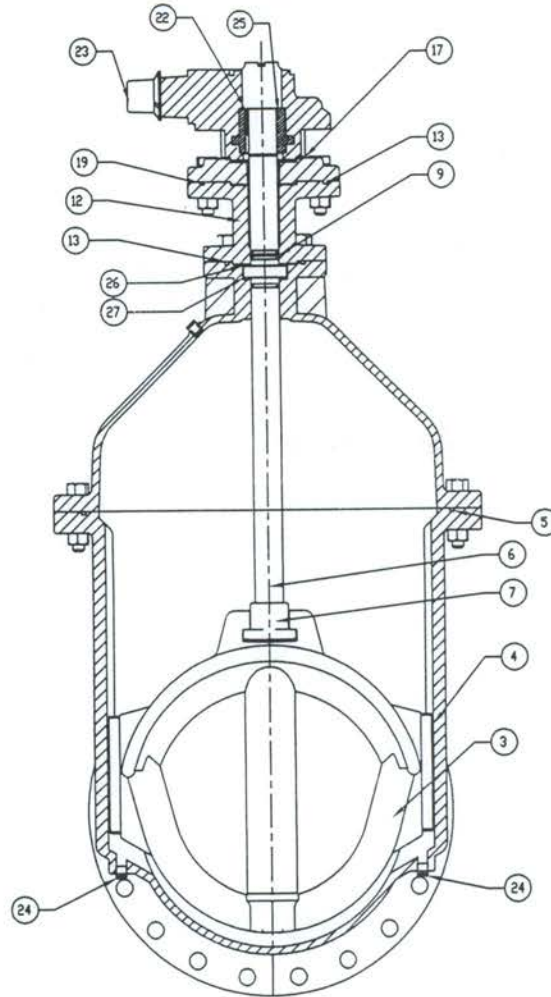
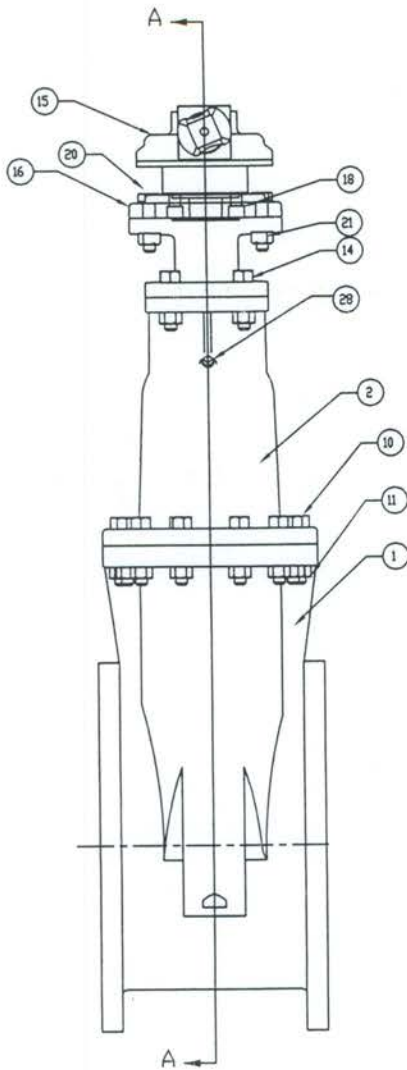

ITEM NO.	DESCRIPTION	MATERIAL	MATERIAL SPECIFICATION
1	Body	Ductile Iron	ASTM A536 65-45-12
2	Cover	Ductile Iron	ASTM A536 65-45-12
3	Wedge	Ductile Iron/Rubber	ASTM A536 65-45-12/EPDM
4	Wedge Cap (18"-20" only)	Delrin	Delrin
** 5	Oring	Rubber	EPDM
6	Stem	Brass	ASTM B584 C86700
** 7	Stem Nut	Brass	ASTM B584 C86700
9	Oring	Rubber	EPDM
10	Hex Head Bolt	Stainless Steel	ASTM F593 304 SST
11	Hex Nut	Stainless Steel	ASTM F594 304 SST
12	Extension	Ductile Iron	ASTM A536 65-45-12
** 13	Oring	Rubber	EPDM
14	Hex Head Bolt	Stainless Steel	ASTM F593 304 SST
15	Actuator - 3:1 (18"-20") 2:1 (14-16")		
16	Adaptor Plate	Ductile Iron	ASTM A536 65-45-12
17	Actuator Gasket	Rubber	NBR
18	Socket Head Bolt	Alloy Steel	Alloy Steel
** 19	Oring	Rubber	EPDM
20	Hex Bolt	Stainless Steel	ASTM F593 304 SST
21	Hex Nut	Stainless Steel	ASTM F594 304 SST
22	Key	Steel	-----
23	Op Nut	Ductile Iron	ASTM A536 65-45-12
24	Pipe Plug - 3/4 NPT with square hd	Stainless Steel	AISI 304
25	Drive Sleeve	Steel	AISI 1023
26	Thrust Bearing	Delrin	-----
27	Thrust Bearing (18"-20" only)	Delrin	-----
28	Pipe Plug - 1/2 NPT with square hd	Stainless Steel	AISI 304

2638-20  
F 10/17/06

\*\* RECOMMENDED SPARE PARTS



Complies with  
AWWA C515

14"-20" R/W VALVE  
SPUR GEAR MATERIAL LIST  
**CLOW VALVE COMPANY**

MODEL 2638

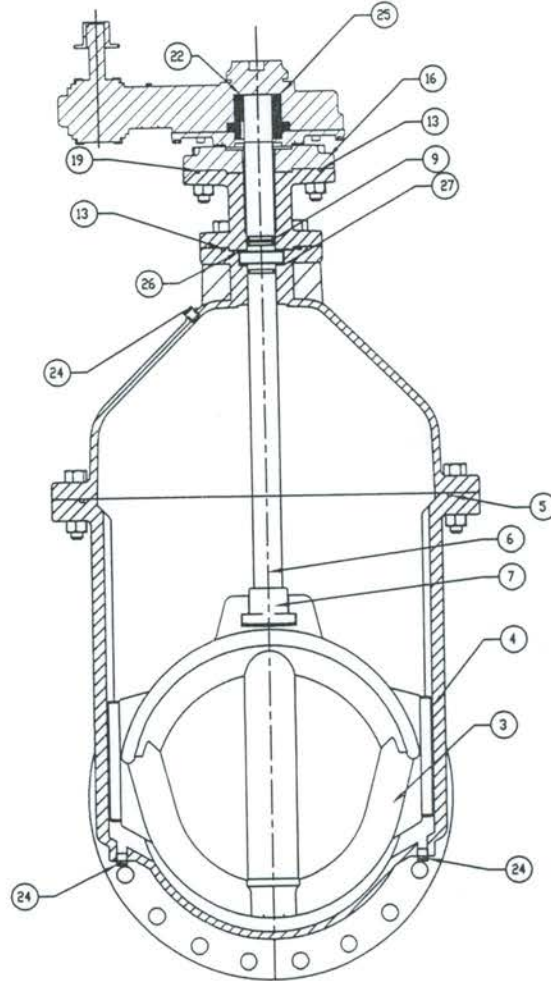
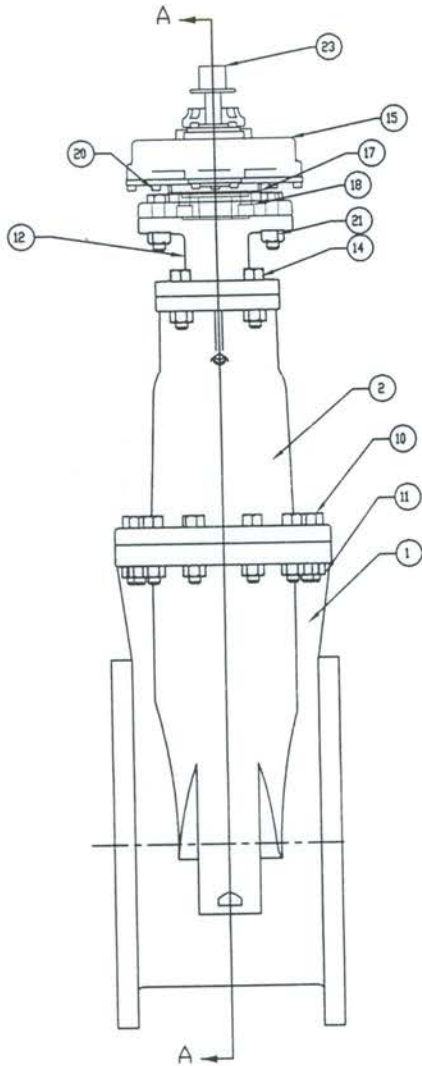

ITEM NO.	DESCRIPTION	MATERIAL	MATERIAL SPECIFICATION
1	Body	Ductile Iron	ASTM A536 65-45-12
2	Cover	Ductile Iron	ASTM A536 65-45-12
3	Wedge	Ductile Iron/Rubber	ASTM A536 65-45-12/EPDM
4	Wedge Cap (18"-24" only)	Delrin	Delrin
** 5	Oring	Rubber	EPDM
6	Stem	Bronze	ASTM B584 C86700
7	Stem Nut	Bronze	ASTM B584 C86700
** 9	Oring	Rubber	EPDM
10	Hex Head Bolt	Stainless Steel	ASTM F593 304 SST
11	Hex Nut	Stainless Steel	ASTM F594 304 SST
12	Extension	Ductile Iron	ASTM A536 65-45-12
** 13	Oring	Rubber	EPDM
14	Hex Head Bolt	Stainless Steel	ASTM F593 304 SST
15	Actuator - 3:1 (18-24") 2:1 (14-16")		
16	Adaptor Plate	Ductile Iron	ASTM A536 65-45-12
17	Actuator Gasket	Rubber	NBR
18	Socket Head Bolt	Alloy Steel	Alloy Steel
** 19	Oring	Rubber	EPDM
20	Hex Bolt	Stainless Steel	ASTM F593 304 SST
21	Hex Nut	Stainless Steel	ASTM F594 304 SST
22	Key	Steel	-----
23	Op Nut	Ductile Iron	ASTM A536 65-45-12
24	Pipe Plug - 3/4 NPT with square hd	Stainless Steel	AISI 304
25	Drive Sleeve	Steel	AISI 1023
26	Thrust Bearing	Delrin	-----
27	Thrust Bearing (18"-20" only)	Delrin	-----

2638-27  
C 07-19-05

\*\*RECOMMENDED SPARE PARTS

2638-84  
D 1/09

24" R/W RTS Bevel Gear  
Parts List

**CLOW VALVE COMPANY**

MODEL 2638

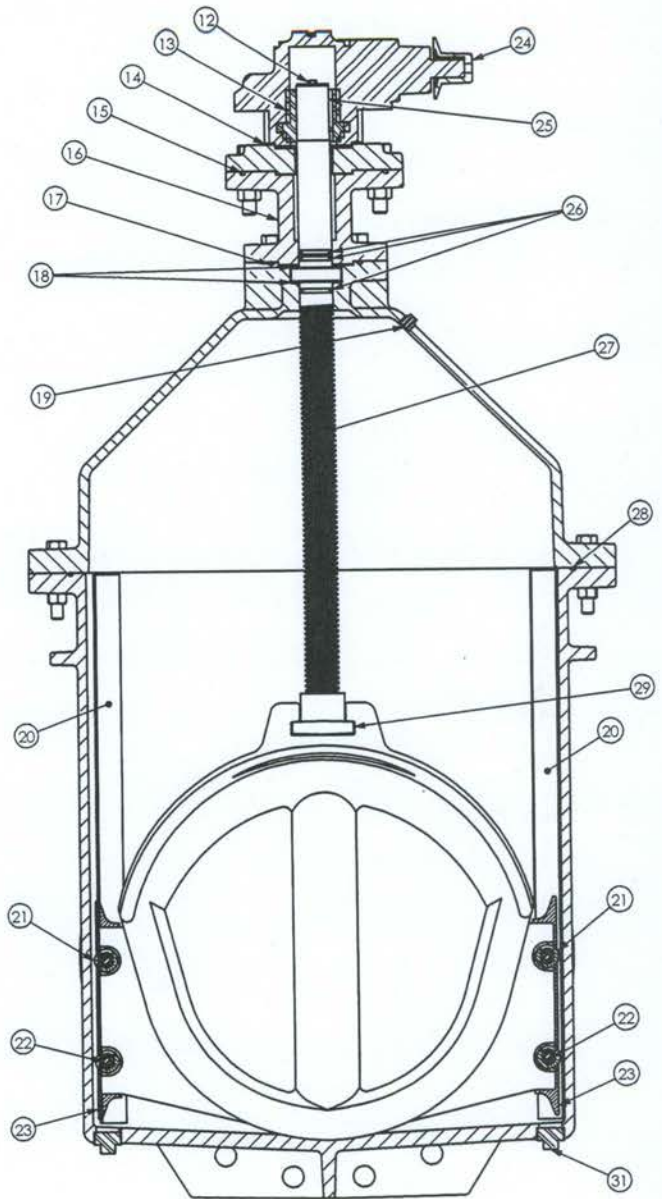
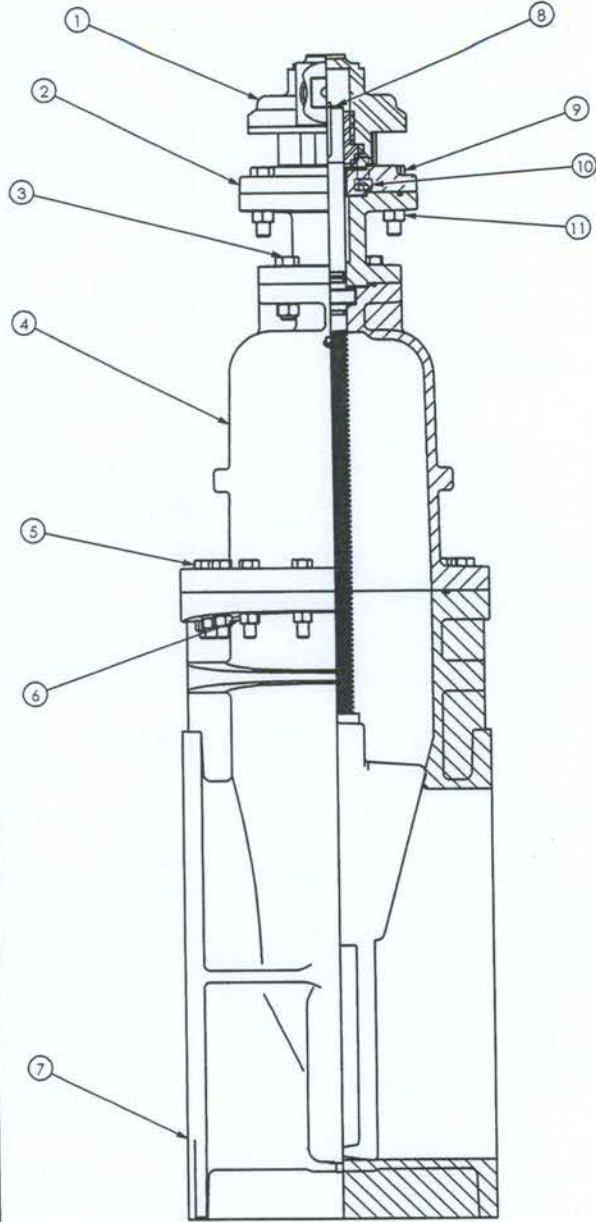

ITEM NO.	DESCRIPTION	MATERIAL	MATERIAL SPECIFICATIONS	ITEM NO.	DESCRIPTION	MATERIAL	MATERIAL SPECIFICATIONS
1	Exeeco IB7 3:1 Actuator	-	-	18	Thrust Washer	Plastic	Delrin
2	Adaptor Plate	Ductile Iron	ASTM A536 65-45-12	19	Pipe Plug	Stainless Steel	AISI 304
3	Hex Head Bolt	Stainless Steel	ASTM F593 304	20	Track	Stainless Steel	AISI 316
4	Cover	Ductile Iron	ASTM A536 65-45-12	21	Roller	Bronze	ASTM B148 C954
5	Hex Head Bolt	Stainless Steel	ASTM F593 304	22	Pin	Stainless Steel	AISI 303
6	Hex Nut	Stainless Steel	ASTM F594 304	23	Scraper	Bronze	ASTM B148 C954
7	Body - Flange	Ductile Iron	ASTM A536 65-45-12	24	Op Nut	Ductile Iron	ASTM A536 65-45-12
8	Washer	Steel	-	25	Key	Steel	AISI 1018
9	Head Head Bolt	Stainless Steel	ASTM F593 304	26	O-Ring	Rubber	EPDM
10	Socket Head Bolt	Stainless Steel	ASTM F593 304	27	Stem	Bronze	ASTM B584 C86700
11	Hex Nut	Stainless Steel	ASTM F594 304	28	O-Ring	Rubber	EPDM
12	Hex Head Bolt	Stainless Steel	ASTM F593 304	29	Stem Nut	Brass	ASTM B584 C83600
13	Drive Sleeve	Steel	AISI 1023	30	Wedge	Ductile Iron / Rubber	ASTM A536 65-45-12 / EPDM
14	Actuator Gasket	Rubber	Buna N	31	Pipe Plug	Stainless Steel	AISI 304
15	O-Ring	Rubber	EPDM				
16	Extension	Ductile Iron	ASTM A536 65-45-12				
17	O-Ring	Rubber	EPDM				



2638-90  
D 01/09

24" RW RTS Spur Gear  
Parts List

**CLOW VALVE COMPANY**

MODEL 2638

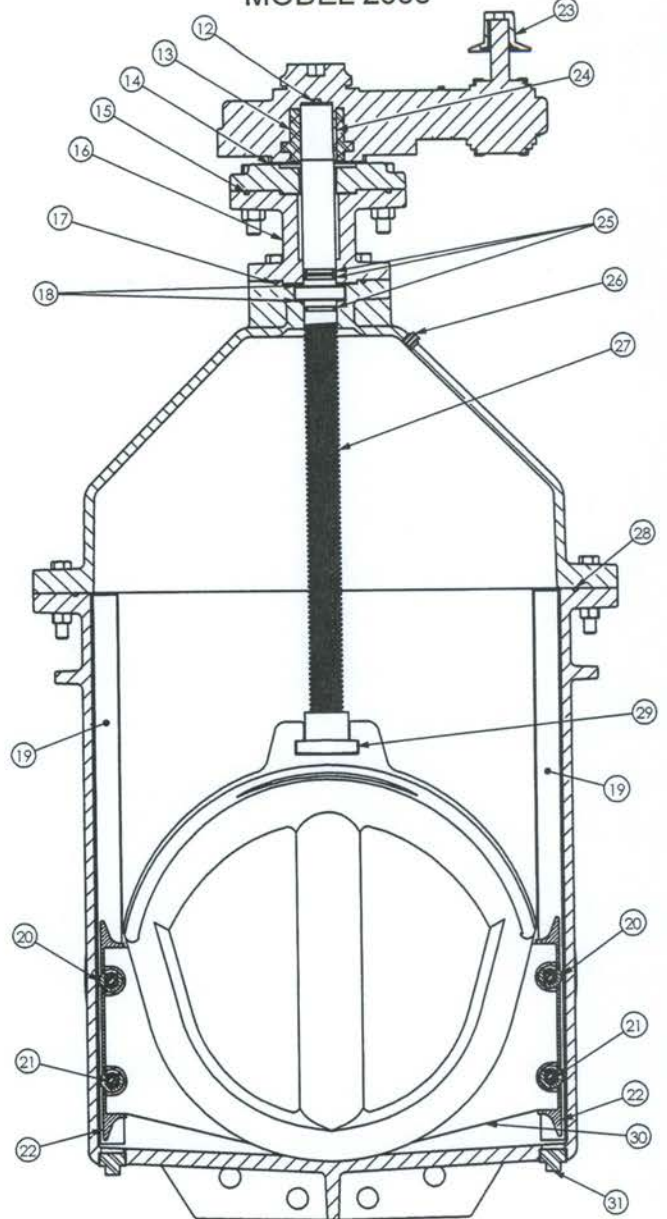
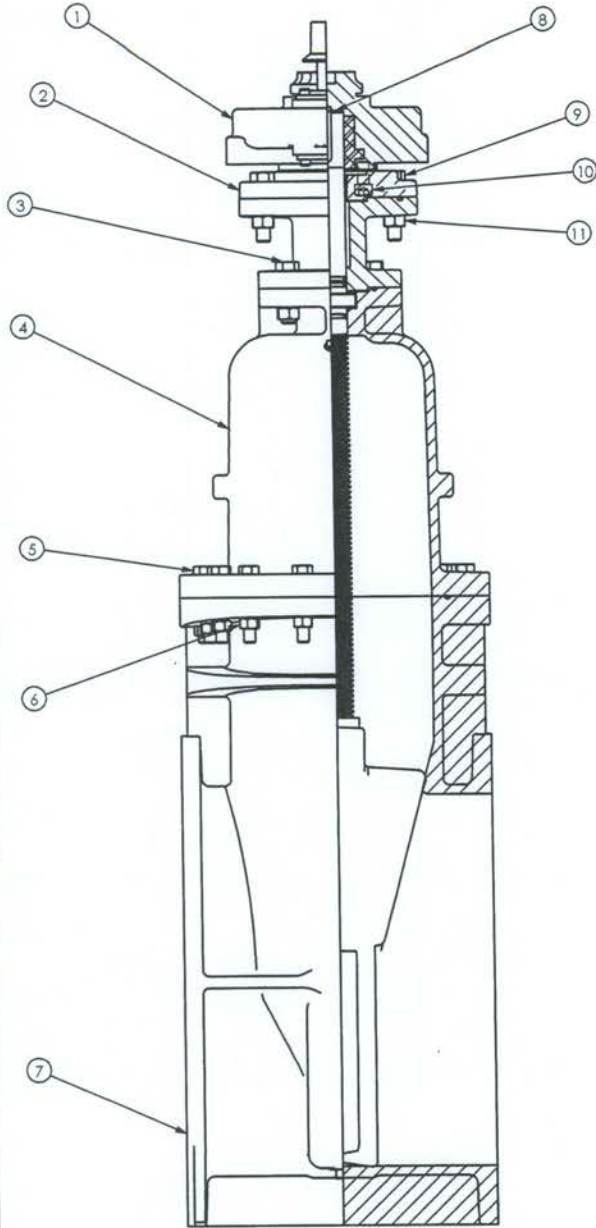

ITEM NO.	DESCRIPTION	MATERIAL	Material Specs	ITEM NO.	DESCRIPTION	MATERIAL	Material Specs
1	Exeeco IS7 3:1 Actuator	-	-	18	Thrust Washer	Plastic	Delrin
2	Adaptor Plate	Ductile Iron	ASTM A536 65-45-12	19	Track	Stainless Steel	AISI 316
3	Hex Head Bolt	Stainless Steel	ASTM F593 304	20	Roller	Bronze	ASTM B148 C954
4	Cover	Ductile Iron	ASTM A536 65-45-12	21	Pin	Stainless Steel	AISI 303
5	Hex Head Bolt	Stainless Steel	ASTM F593 304	22	Scraper	Bronze	ASTM B148 C954
6	Hex Nut	Stainless Steel	ASTM F594 304	23	Op Nut	Ductile Iron	ASTM A536 65-45-12
7	Body - Flange	Ductile Iron	ASTM A536 65-45-12	24	Key	Steel	AISI 1018
8	Washer	Steel	-	25	O-Ring	Rubber	EPDM
9	Head Head Bolt	Stainless Steel	ASTM F593 304	26	Pipe Plug	Stainless Steel	AISI 304
10	Socket Head Bolt	Stainless Steel	ASTM F593 304	27	Stem	Bronze	ASTM B584 C86700
11	Hex Nut	Stainless Steel	ASTM F594 304	28	O-Ring	Rubber	EPDM
12	Hex Head Bolt	Stainless Steel	ASTM F593 304	29	Stem Nut	Brass	ASTM B584 C83600
13	Drive Sleeve	Steel	AISI 1023	30	Wedge	Ductile Iron / Rubber	ASTM A536 65-45-12 / EPDM
14	Actuator Gasket	Rubber	Buna N	31	Pipe Plug	Stainless Steel	AISI 304
15	O-Ring	Rubber	EPDM				
16	Extension	Ductile Iron	ASTM A536 65-45-12				
17	O-Ring	Rubber	EPDM				

## **Dis-assembly Instructions 14"-24" Geared Valve**

### **Ref; 14"-24" RW Valve Material List (page 5 or 6)**

1. Remove 3" NPT plug on top of gear.
  2. Remove capscrew and large washer under pipe plug.
  3. Remove (4)bolts (20) and (4) nuts (21) between adapter plate (16) and extension.
  4. Lift off gear assembly (15) and adapter plate (16). Retain key (22).
  5. Remove (4) bolts & nuts (14).
  6. Lift off extension (12).
  7. Remove stem (6) by turning the stem in the opposite direction of opening the valve.
  8. Remove neck flange bolts and nuts (10&11).
  9. Lift off cover (2).
  10. Grasp stem nut (7) and lift out wedge (3). **Note; Threading stem back into stem nut may make removal of wedge easier.**
  11. Reassemble in reverse order replacing cover o-ring (5), extension o-ring (13), and adapter plate o-ring (19) if necessary.
- 

## **Dis-assembly Instructions 24" Geared Valve**

### **Ref: page 7 or 8 (valve material parts list drawing)**

1. Remove 3" NPT plug on top of gear.
2. Remove capscrew and large washer under pipe plug.
3. Remove (40 bolts (9) and (4) nuts (11) between adapter plate (2) and extension.
4. Lift off gear assembly (1) and adapter plate (2). Retain key (25).
5. Remove (4) bolts & nuts (3).
6. Lift off extension (16).
7. Remove stem (27) by turning the stem in the opposite direction of opening the valve.
8. Remove neck flange bolts and nuts (5&6).
9. Lift off cover (4).
10. Grasp stem nut (29) and lift out wedge (31). **NOTE; Threading stem back into stem nut may make removal of wedge easier.**
11. Reassemble in reverse order replacing cover o-ring (28), extension o-ring (17), and adapter plate o-ring (15) if necessary.

2638-50  
A 9-23-02

30"-48" R/W VALVE  
BEVEL GEAR ASSEMBLY  
**CLOW VALVE COMPANY**

MODEL 2638

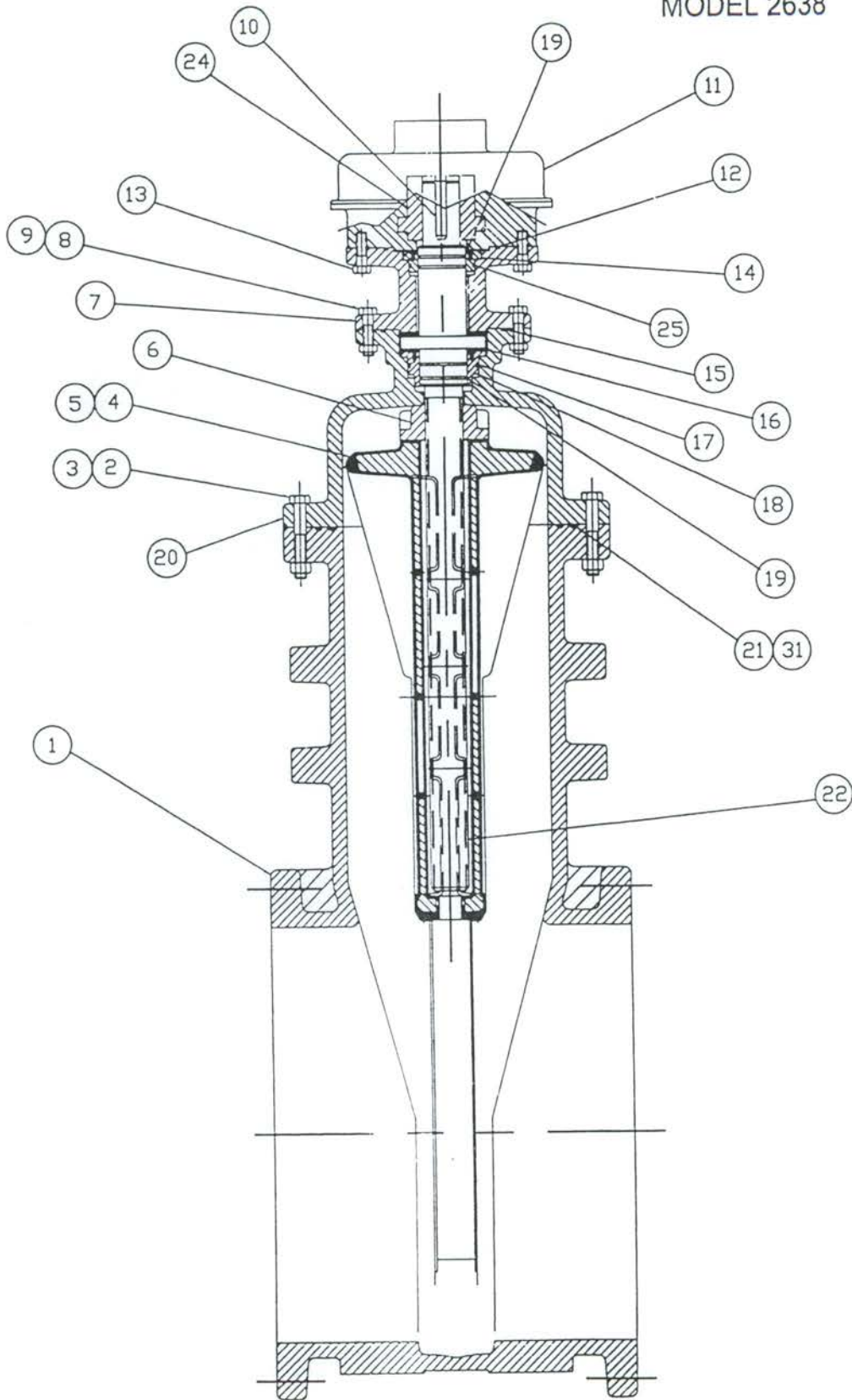



30"-48" R/W VALVE  
BEVEL GEAR ASSEMBLY  
**CLOW VALVE COMPANY**

MODEL 2638

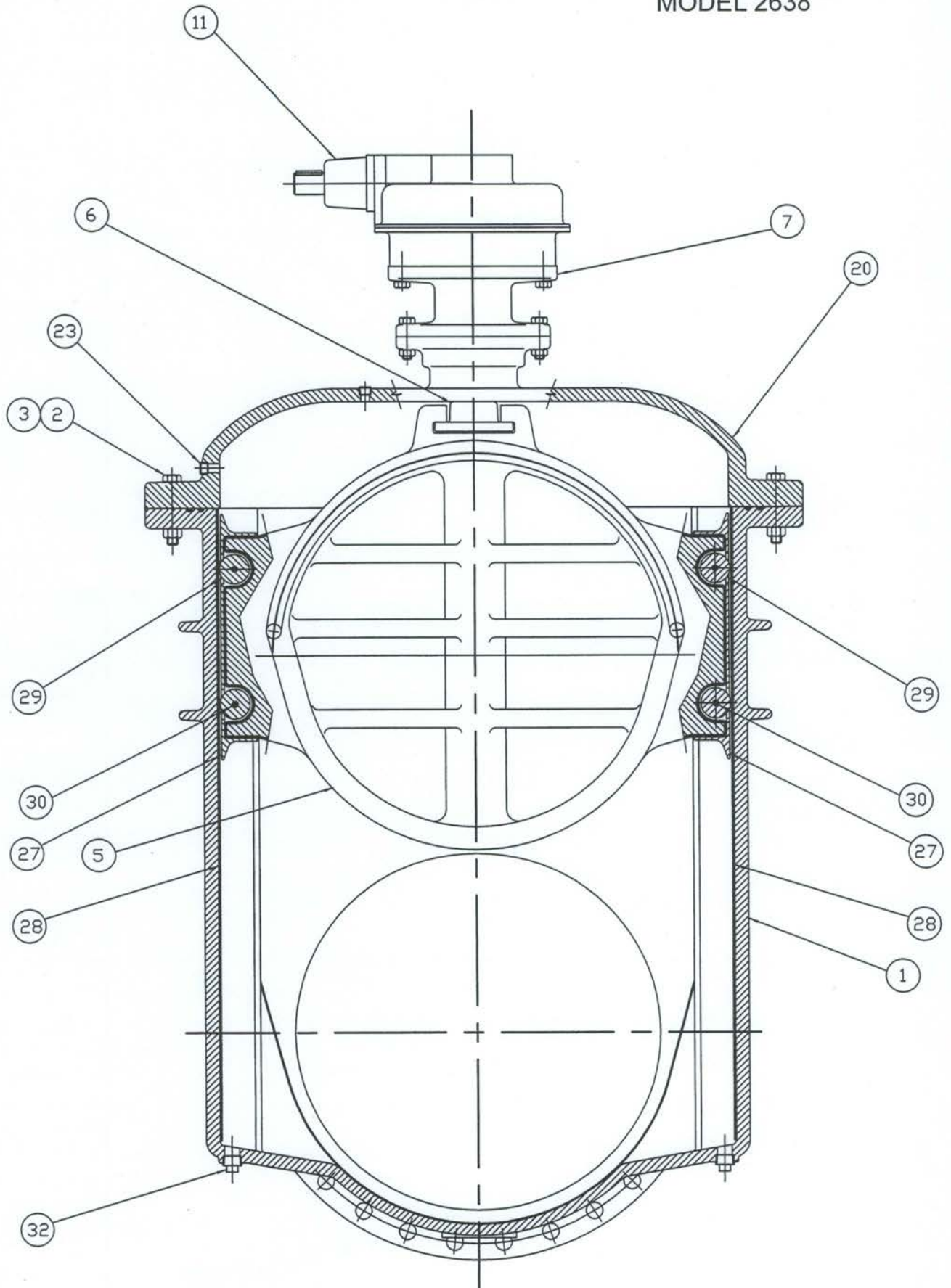

30"-36" RW VALVE  
BEVEL GEAR PARTS LIST  
**CLOW VALVE COMPANY**

MODEL 2638

Item	Description	Material
1	Body - Mechanical Joint	ASTM A536 Ductile iron
	Body - Flange	ASTM A536 Ductile iron
	Body - MJ x Flange	ASTM A536 Ductile iron
2	Bolt	AISI 304 Stainless Steel
3	Nut	AISI 304 Stainless Steel
4	Wedge Casting	ASTM A536 Ductile iron
5	Molded Wedge	EPDM
6	Stem Nut	ASTM B763 alloy 995 Brass
7	Extension - actuator	ASTM A536 Ductile iron
8	Bolt	AISI 304 Stainless Steel
9	Nut	AISI 304 Stainless Steel
10	Key	Steel
11	Actuator - bevel gear	
12	O-ring	EPDM
13	Bolt	AISI 304 Stainless Steel
14	Bushing - stem guide	ASTM B584 alloy 836 Brass
15	O-ring	EPDM
16	Thrust Bearing	Nylatron
17	O-ring	EPDM
18	Cover Bushing	ASTM B584 alloy 836 Brass
19	O-ring	EPDM
20	Cover	ASTM A536 Ductile iron
21	O-ring - cover outer	EPDM
22	Stem	ASTM B763 alloy 995 Brass
23	Pipe Plug	AISI 304 Stainless Steel
24	Actuator Drive Bushing	Bronze
25	O-ring	EPDM
27	Scraper	ASTM B148 C954 Al Bronze
28	Track	AISI 316 Stainless Steel
29	Roller	ASTM B148 C954 Al Bronze
30	Pin - roller	AISI 316 Stainless Steel
31	O-ring - cover inner	EPDM
32	Pipe Plug	AISI 304 Stainless Steel



30"-48" R/W VALVE  
SPUR GEAR ASSEMBLY  
**CLOW VALVE COMPANY**

MODEL 2638

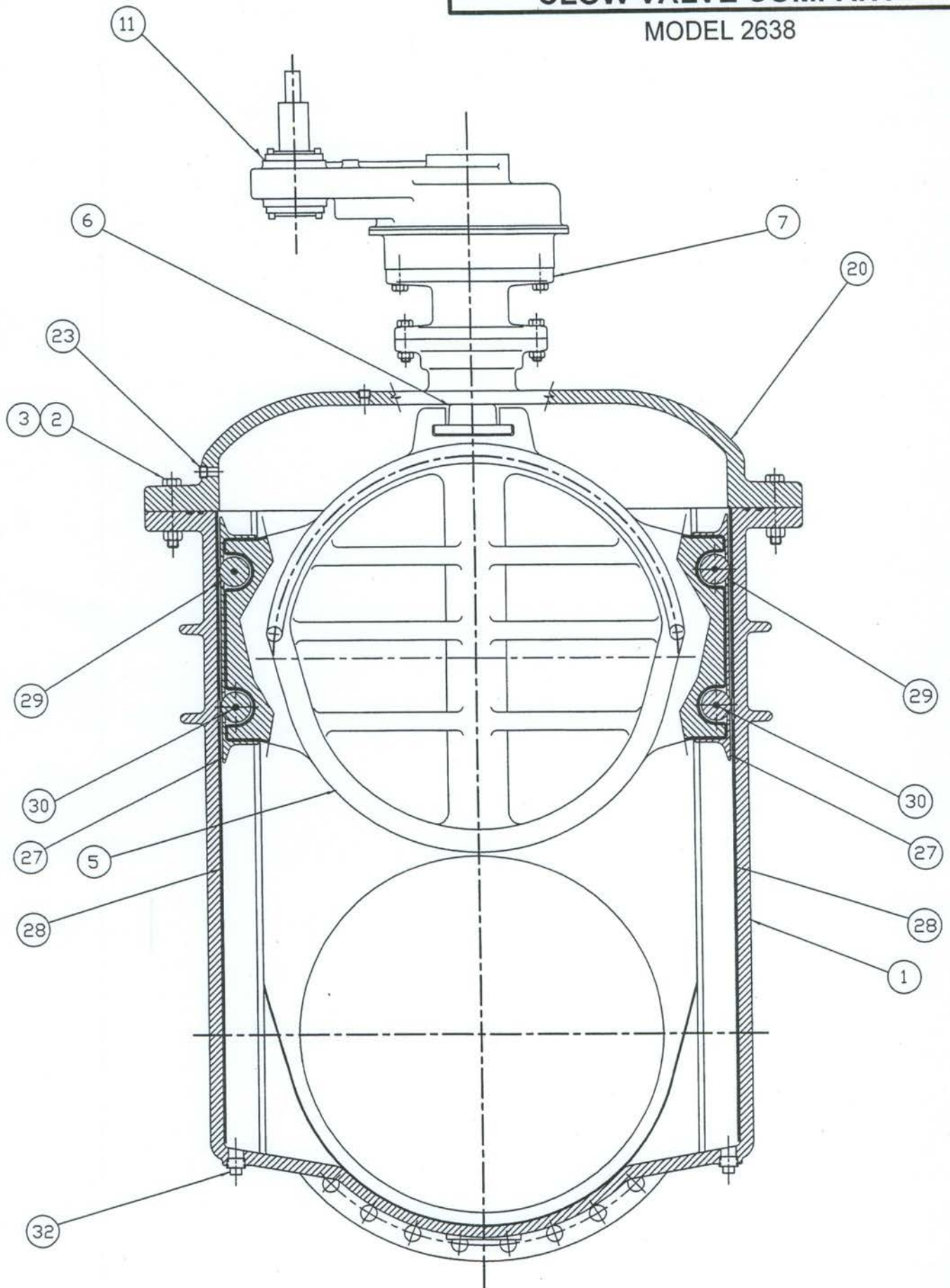



2638-57  
A 3-2-04

30"-48" R/W VALVE  
SPUR GEAR ASSEMBLY  
**CLOW VALVE COMPANY**

MODEL 2638

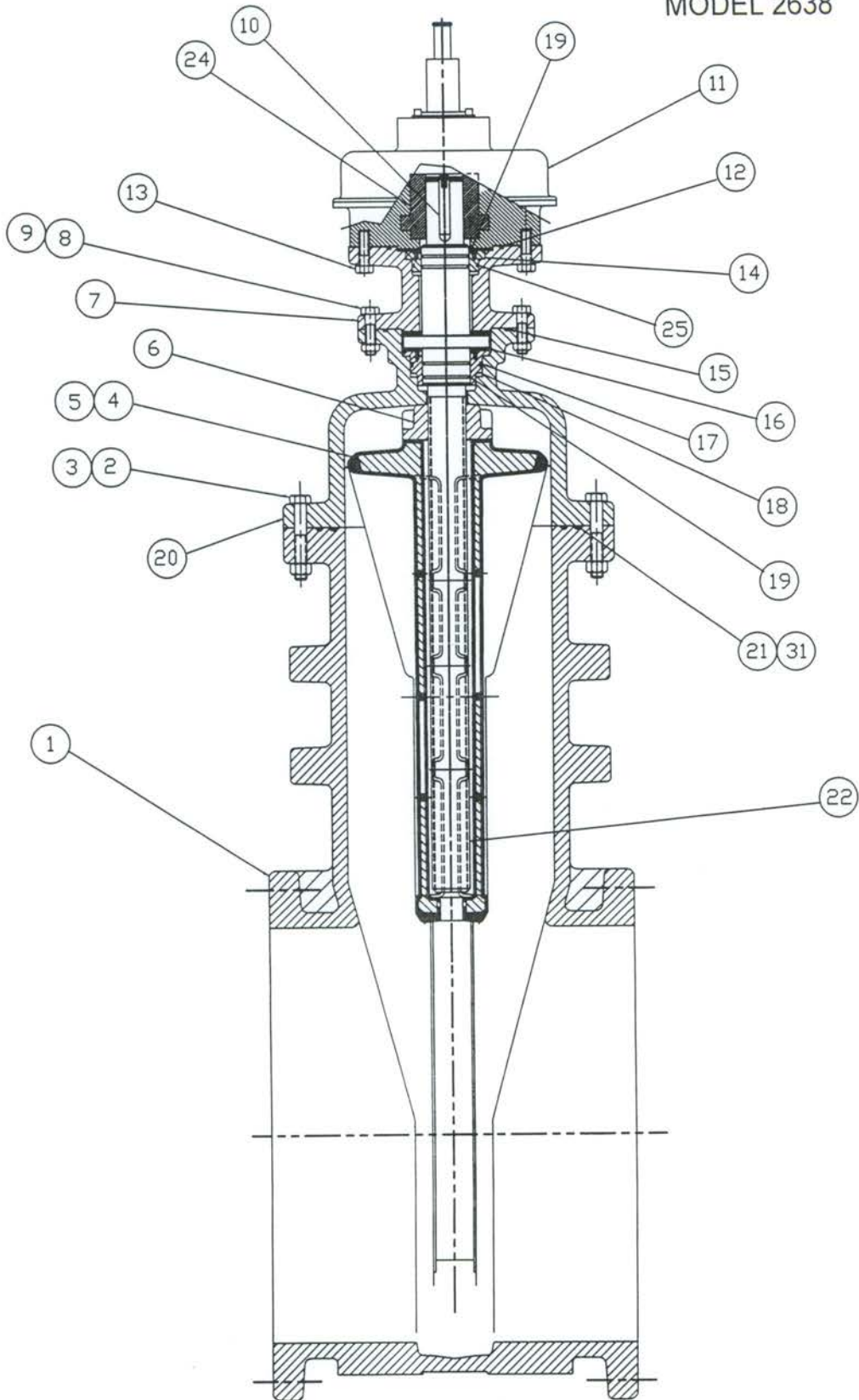

30"-48" RW VALVE  
SPUR GEAR PARTS LIST  
**CLOW VALVE COMPANY**

MODEL 2638

Item	Description	Material
1	Body - Mechanical Joint	ASTM A536 Ductile Iron
	Body - Flange	ASTM A536 Ductile Iron
	Body - MJ x Flange	ASTM A536 Ductile Iron
2	Bolt - 7/8-9NC hex hd x 5-1/2 lg	AISI 304 Stainless Steel
3	Nut - 7/8-9NC hex	AISI 304 Stainless Steel
4	Wedge Casting	ASTM A536 Ductile Iron
5	Molded Wedge	EPDM
6	Stem Nut	ASTM B763 alloy 995 Brass
7	Extension - actuator	ASTM A536 Ductile Iron
8	Bolt - 3/4-10NC x 3' lg hex hd	AISI 304 Stainless Steel
9	3/4-10NC hex nut	AISI 304 Stainless Steel
10	Key	Square Seel Keystock
11	Actuator - spur gear	
12	□-ring	EPDM
13	Bolt - 3/4-10NC x 2-1/2 lg hex hd	AISI 304 Stainless Steel
14	Bushing - stem guide	ASTM B584 alloy 836 Brass
15	□-ring	EPDM
16	Thrust Bearing	Nylatron
17	□-ring	EPDM
18	Cover Bushing	ASTM B584 alloy 836 Brass
19	□-ring #236	EPDM
20	Cover	ASTM A536 Ductile Iron
21	□-ring - cover outer	EPDM
22	Stem	ASTM B584 alloy 867 Brass
23	Pipe Plug - 3/4 NPT w/ square hd	AISI 304 Stainless Steel
24	Actuator Drive Bushing	Bronze
25	□-ring	EPDM
27	Scraper	ASTM B148 C954 Al Bronze
28	Track	AISI 316 Stainless Steel
29	Roller	ASTM B148 C954 Al Bronze
30	Pin - roller	AISI 316 Stainless Steel
31	□-ring - cover inner	EPDM
32	Pipe Plug	AISI 304 Stainless Steel

### **Dis-assembly 30"-48" Geared Valve**

#### **Ref. 30"-48" RW GV ASSEMBLY DRAWINGS PAGES 10-15**

1. Remove NPT pipe plug from top of gear.
2. Remove capscrew and large washer under pipe plug.
3. Remove (8) capscrews (13) from underside of gear.
4. Lift off gear assembly (11) retain key (10).
5. Remove (8) bolts & nuts (8&9) between extension (7) and cover (20).
6. Lift off extension (7).
7. Remove stem (22) by turning the stem in the opposite direction for opening the valve.  
**Note; Lifting device will be required for disassembly.**
8. Remove neck flange bolts and nuts (2&3) .
9. Lift off cover (20).
10. Thread stem (22) back into stem nut (6). Lift out wedge (5).
11. Reassemble in reverse order replacing cover o-ring (7) and follower o-ring (2) if necessary.



**Troubleshooting  
RW GV'S**

Possible Malfunction	Symptoms – Causes	Corrective Action
<i>Joint Leakage</i>	<i>Bolt Tension Relaxing</i>	<i>Tighten Bolts</i>
<i>Seat Leakage</i>	<i>Foreign material caught in seat</i>	<i>Operate valve to flush Out debris.</i>
	<i>Seats Dirty/Corroded</i>	<i>Flush or dis-assemble &amp; clean.</i>
	<i>Seats Damaged</i>	<i>Inspect-repair or Replace</i>
<i>Leak Past Stem</i>	<i>Bolts loose</i>	<i>Tighten Bolts</i>
	<i>(NRS) Orings worn/damaged</i>	<i>Inspect/replace</i>
	<i>(OS&amp;Y) Packing worn/damaged</i>	<i>Inspect/replace</i>

*Inspection for the above should be done semi/annually at the minimum.  
There are no lubrication requirements other than;  
OS&Y valves should have the exposed stem \*\*lubricated at each inspection.  
\*\* Food grade grease similar to Mystic FG2*

---

*For Parts and Service Contact mfg's rep:*

# INSTRUCTIONS FOR USE

## BEVEL GEAR OPERATORS

Bevel Range Specification:  
Installation, Operating and Maintenance Instructions:  
Assembly and Dismantling Instructions:  
Spare Parts List and Recommended 5 Years Holding List:

Rotork Gears,

Regina House,  
Branley,  
Leeds,  
LS13 3TT.

## ROTORK GEARS BEVEL RANGE SPECIFICATION

Component	Material Specification												
Gearcase	Cast Iron as standard, optional SG Iron, Carbon Steel or Stainless Steel.												
Baseplate	SG Iron as standard, optional Cast Iron, Carbon Steel or Stainless Steel.												
Input Housing	Cast Iron as standard, optional SG Iron, Carbon Steel or Stainless Steel.												
Bevel Gear	SG Iron or Carbon Steel.												
Pinion Gear & Shaft	Carbon Steel as standard, optional Stainless Steel.												
Spigot Ring	SG Iron as standard, optional Cast Iron.												
Screws	High Tensile Steel Metric Standard to BS3692 & 4168 as standard, optional Stainless Steel.												
Bearings	Input Shaft - Ball type. Thrust Output - Needle roller type with thrust washers (with the exception of size 14, which has cylindrical roller thrust bearings and RAB range, which have taper roller bearings).												
Output Sleeve A1 (for non rising valve spindles)	Steel.												
Output Sleeve A2 (for rising valve spindles)	Aluminium Bronze.												
Finish	PA 24 Grey Primer (Standard). Primer and Enamel Gloss (Optional). Other finishes available on request.												
Lubricant	<table style="width: 100%; border: none;"> <tr> <td style="width: 50%; border: none;">CL-X2 (Standard) max temp 120°C:</td> <td style="width: 50%; border: none;">Ignition temperature &gt; 250°C</td> </tr> <tr> <td style="border: none;">LX-EP2 (High temp) max temp 160°C:</td> <td style="border: none;">Ignition temperature &gt; 250°C</td> </tr> <tr> <td style="border: none;">MHF-H1 (Food) max temp 177°C:</td> <td style="border: none;">Ignition temperature &gt; 260°C</td> </tr> <tr> <td style="border: none;">MO2 (Graphite) max temp 120°C:</td> <td style="border: none;">Flash point &gt; 200°C</td> </tr> <tr> <td style="border: none;">G110 (Nuclear) max temp 150°C:</td> <td style="border: none;">Flash point &gt; 200°C</td> </tr> <tr> <td style="border: none;">G130 (Nuclear) max temp 150°C:</td> <td style="border: none;">Flash point &gt; 200°C</td> </tr> </table>	CL-X2 (Standard) max temp 120°C:	Ignition temperature > 250°C	LX-EP2 (High temp) max temp 160°C:	Ignition temperature > 250°C	MHF-H1 (Food) max temp 177°C:	Ignition temperature > 260°C	MO2 (Graphite) max temp 120°C:	Flash point > 200°C	G110 (Nuclear) max temp 150°C:	Flash point > 200°C	G130 (Nuclear) max temp 150°C:	Flash point > 200°C
CL-X2 (Standard) max temp 120°C:	Ignition temperature > 250°C												
LX-EP2 (High temp) max temp 160°C:	Ignition temperature > 250°C												
MHF-H1 (Food) max temp 177°C:	Ignition temperature > 260°C												
MO2 (Graphite) max temp 120°C:	Flash point > 200°C												
G110 (Nuclear) max temp 150°C:	Flash point > 200°C												
G130 (Nuclear) max temp 150°C:	Flash point > 200°C												
Seals	<table style="width: 100%; border: none;"> <tr> <td style="width: 50%; border: none;">Nitrile (Standard) max temp 150°C:</td> <td style="width: 50%; border: none;">Ignition temperature &gt; 300°C</td> </tr> <tr> <td style="border: none;">Viton (High temp/ Nuclear) max temp 200°C:</td> <td style="border: none;">Ignition temperature &gt; 315°C</td> </tr> <tr> <td style="border: none;">Fluorosilicone (Low temp) max temp 225°C:</td> <td style="border: none;">Ignition temperature &gt; 300°C</td> </tr> <tr> <td style="border: none;">Silicone sealant max temp 200°C:</td> <td style="border: none;">Ignition temperature &gt; 450°C</td> </tr> </table>	Nitrile (Standard) max temp 150°C:	Ignition temperature > 300°C	Viton (High temp/ Nuclear) max temp 200°C:	Ignition temperature > 315°C	Fluorosilicone (Low temp) max temp 225°C:	Ignition temperature > 300°C	Silicone sealant max temp 200°C:	Ignition temperature > 450°C				
Nitrile (Standard) max temp 150°C:	Ignition temperature > 300°C												
Viton (High temp/ Nuclear) max temp 200°C:	Ignition temperature > 315°C												
Fluorosilicone (Low temp) max temp 225°C:	Ignition temperature > 300°C												
Silicone sealant max temp 200°C:	Ignition temperature > 450°C												

Gearbox Detail	Gearbox Specification										
Gearbox design Life	850 hours ( 20 minutes a day for 7 years)										
Gears	Designed basically to BS545.										
Gearbox type	Indicated on the nameplate										
Gearbox ratio	Indicated on the nameplate										
Maximum output torque	Indicated in the Rotork Gears catalogue										
Maximum thrust	Indicated in the Rotork Gears catalogue										
Gearbox duty specification	Indicated on the nameplate										
Nameplate Explosion Marking and Category	According to 94/9/EC and indicated on the nameplate										
Maximum speed for the input shaft	350 rpm										
Maximum bending moment on the input flange	<table style="width: 100%; border: none;"> <tr> <td style="width: 50%; border: none;">F10:</td> <td style="width: 50%; border: none;">66Nm</td> </tr> <tr> <td style="border: none;">F14:</td> <td style="border: none;">178Nm</td> </tr> <tr> <td style="border: none;">F16:</td> <td style="border: none;">210Nm</td> </tr> <tr> <td style="border: none;">F25:</td> <td style="border: none;">700Nm</td> </tr> <tr> <td style="border: none;">F30:</td> <td style="border: none;">770Nm</td> </tr> </table>	F10:	66Nm	F14:	178Nm	F16:	210Nm	F25:	700Nm	F30:	770Nm
F10:	66Nm										
F14:	178Nm										
F16:	210Nm										
F25:	700Nm										
F30:	770Nm										
Maximum operating temperature	Indicated on the nameplate										
Gearbox weight	Indicated on the nameplate										



# INSTALLATION, OPERATING AND MAINTENANCE INSTRUCTIONS FOR BEVELS AND SPURS GEAR OPERATORS

The Rotork Gears Spur and Bevel Range Specification sheets indicate the materials of construction and information for putting the equipment into service. The gearbox is marked according to 94/9/EC with the temperature class and explosion group on the equipment and this shall be observed when installing and operating the equipment. The user alone is responsible for the appropriate use of the gearbox in consideration of the basic conditions existing at the plant.

This range of gearboxes is supplied to suit the order requirements but, unless specifically requested at the ordering stage, the output sleeve will be supplied blank and must be machined to suit the equipment to be operated. NTB gearboxes do not have a removable output sleeve.

A thrust element retention device is normally fitted to the baseplate for transporting purposes and **MUST** be removed to access the output sleeve. The output sleeve can be easily removed from the gearbox by first removing the loose piece spigot ring from the baseplate. It is imperative that the thrust bearings in the output are re-assembled correctly, along with the output sleeve and the spigot ring - That is: models that use needle roller thrust bearings **MUST** have a thrust washer at each side of the needle race. A bearing / washer assembly **MUST** be fitted at each side of the output sleeve thrust shoulder. Models with taper roller bearings **MUST** be assembled with the bearings correctly orientated. All thrust elements and bearing cavities must be packed with grease of the correct specification.

## NOTES FOR MOUNTING TO THE VALVE

1. The valve spindle must be greased before assembly of the gearbox to the valve.
2. Thrust element retention device to be removed prior to assembly to the valve.
3. Do not pack the spindle cover tube with grease as this can lead to pressure build up in the gearbox.
4. Flanges to be sealed on assembly with silicone sealant.
5. Spindle cover tubes and plugs to be sealed with suitable sealant.

If the gearbox has been supplied with a handwheel, it is recommended that this be fitted to the gearbox before mounting on the valve. This will make it easier to rotate the gearing to pick up the start of a thread or key location.

On a keyed valve shaft, once the key and keyway are lined up, the gearbox can be lowered onto the mounting flange and bolted down.

On a screwed valve shaft, rotating the handwheel will cause the gearbox to screw itself down the spindle. Once in the correct position it can be bolted down.

For large gearboxes, IB8 to IB14 and IS7 to IS20, we recommend fitting the thrust elements onto the valve prior to fitting the gearbox. The spigot ring and one set of thrust washers and bearings can be placed onto the valve first, then the output sleeve can be screwed down or fitted onto the spindle key, depending on the valve spindle design. The second set of thrust washers and bearings are then fitted. The gearbox then can be lowered onto the valve, taking care that the splines in the output gear and output sleeve do not get damaged.

When bolting the valve to the gearbox we recommend using at least grade 8.8 fasteners, and these **MUST** be torque tightened dependent upon the grade and size used.

If an electric actuator is fitted to the gearbox, a suitable input adaptor will have been supplied. After mounting the actuator to the gearbox, the limit and torque switch settings must be made in accordance with the manufacturer's instructions. The maximum permitted bending moment on the input adaptor of the gearbox is indicated on the gearbox specification sheet.

## HANDLING

Combined valve, actuator and gearbox must **NOT** be slung from the gearbox.

## MAINTENANCE

All gear cavities are lubricated and sealed for life and the type of grease and seals used within the gearbox is indicated on the nameplate and shown in the material specification. The required maintenance intervals depend on the respective application and will therefore have to be determined by the user dependent on the conditions of use. Annual inspection of the gearbox is recommended, but under normal operating conditions no maintenance is required for the gearbox, but should the valve be taken out of service for overhaul, the gearbox baseplate may be removed and the grease renewed. The baseplate must be sealed using silicone sealant on re-assembly, unless fitted with an O ring. Below is a table for the recommended tightening of screws.

SCREW SIZE	HEXAGON HEAD GRADE 8.8		HEXAGON HEAD GRADE 8.8 WITH NORDLOCK WASHER		SOCKET HEAD GRADE 12.9		SOCKET HEAD GRADE 12.9 WITH NORDLOCK WASHER		DURLOK GRADE 12.9 SCREW GRADE 12 NUT	
	TORQUE TIGHTNESS (Nm)	TORQUE TIGHTNESS (lbsft)	TORQUE TIGHTNESS (Nm)	TORQUE TIGHTNESS (lbsft)	TORQUE TIGHTNESS (Nm)	TORQUE TIGHTNESS (lbsft)	TORQUE TIGHTNESS (Nm)	TORQUE TIGHTNESS (lbsft)	TORQUE TIGHTNESS (Nm)	TORQUE TIGHTNESS (lbsft)
M4	2	2	3	2	4	3	5	4		
M5	5	4	6	4	8	6	10	7	11	8
M6	9	6	10	8	14	11	17	13	19	14
M8	21	15	25	18	35	26	42	31	45	33
M10	41	30	49	36	69	51	83	61	86	64
M12	71	53	86	63	121	89	145	107	152	112
M16	177	131	213	157	299	221	359	265	372	274
M20	346	255	415	306	584	431	701	517	717	529
M24	598	441	718	529	1009	744	1211	893		
M30					2006	1480				
M36					3508	2587				

Note: Once fully torque tightened Durlok fasteners must not be re used on Nuclear gearboxes.  
Copy of QC 40-2

NB. All thrust elements and bearing cavities must be re-greased and refitted in the correct order.

## SPARES

Spare parts must be selected from the spare parts lists and a recommended spares holding for 5 years is shown on the spare parts list.

C.F. 29.05.03 issue 1

F:\EXE\CO\GBOX\ENGINEER\ATEX\Instructions\Bevel\Installation Instructions for Bevel-Spur.doc

**PROCEDURE FOR**  
**DISMANTLING / RE-ASSEMBLY OF BEVEL GEAR OPERATORS**

1. **PURPOSE:** To provide dismantling / re-assembly instructions.
2. **SCOPE:** Rotork Gears range of bevel gearboxes
3. **DEFINITION:** Sequence of instructions to dismantle and re-assemble Rotork Gears bevel gearboxes.
4. **PROCEDURE:** Refer to spare parts list for item numbers.

**4.1 Dismantling**

- 4.1.1 Remove the key (17) from the input shaft (5).
- 4.1.2 Remove the 4 off socket head cap screws (20), which secure the input housing (3) to the gearcase (1).
- 4.1.3 Remove the input housing from the gearcase complete with the input shaft, bearings (10) and spacer (11) where applicable.
- 4.1.4 Remove the input shaft from the housing.
- 4.1.5 Remove the 8 off socket head cap screws (21), which secure the baseplate (2) to the gearcase.
- 4.1.6 Remove the baseplate from the gearcase. The bevel gear (4) will probably remain on the splines of the output sleeve (6) for IB, RAB and HOB gearboxes.
- 4.1.7 Remove the bevel gear from the output sleeve on the IB, RAB or HOB, or from the baseplate or gearcase of the NTB gearbox.
- 4.1.8 Remove the spigot ring (7), bearings (8), thrust washers (9), where applicable, and output sleeve from the baseplate of the IB, RAB or HOB gearbox.

**4.2 Re-assembly**

- 4.2.1 Ensure the bevel gear and baseplate are free from dirt and bruising and then fit the 'o' ring (14) to the bevel gear.
- 4.2.2 Fit the 'o' ring (15) to the gearcase and re-pack the gearcase with grease (22).
- 4.2.3 Re-fit the output gear into the gearcase ensuring that the 'o' ring (15) remains undamaged.
- 4.2.4 Grease the back face of the bevel gear before re-fitting the baseplate.
- 4.2.5 Fit the 'o' ring (24) to the baseplate and re-fit the baseplate into the gearcase. For the NTB gearbox also fit the 'o' ring (13) onto the output gear prior to fixing the baseplate.
- 4.2.6 Re-secure the gearcase to the baseplate using the existing screws (21) using a diagonal tightening movement.
- 4.2.7 Reassemble the input housing sub assembly with the input shaft, spacer and bearings ensuring are parts are clean and repack the housing with grease. Fit the 'o' rings (16 and 23) in the housing.
- 4.2.8 Re-fit the input housing sub-assembly into the gearcase ensuring that the input shaft gear locates into the bevel gear.
- 4.2.9 Secure the input housing to the gearcase with the existing screws (20) using a diagonal tightening movement.
- 4.2.10 Re-fit the key to the input shaft.
- 4.2.11 For IB, RAB and HOB gearboxes apply grease to the thrust bearings and washers, where applicable, and re assemble the output sleeve and spigot assembly into the baseplate. Ensure that the 'o' ring (14) remains undamaged.
- 4.2.12 Test the gearbox for free rotation.

**5. DOCUMENTATION**

Spare parts list for range of bevel gear actuators: Bevel Part List.doc  
Torque tightening figures. Document No QC 40-2



# SPARE PARTS LIST FOR RANGE OF BEVEL GEAR OPERATORS

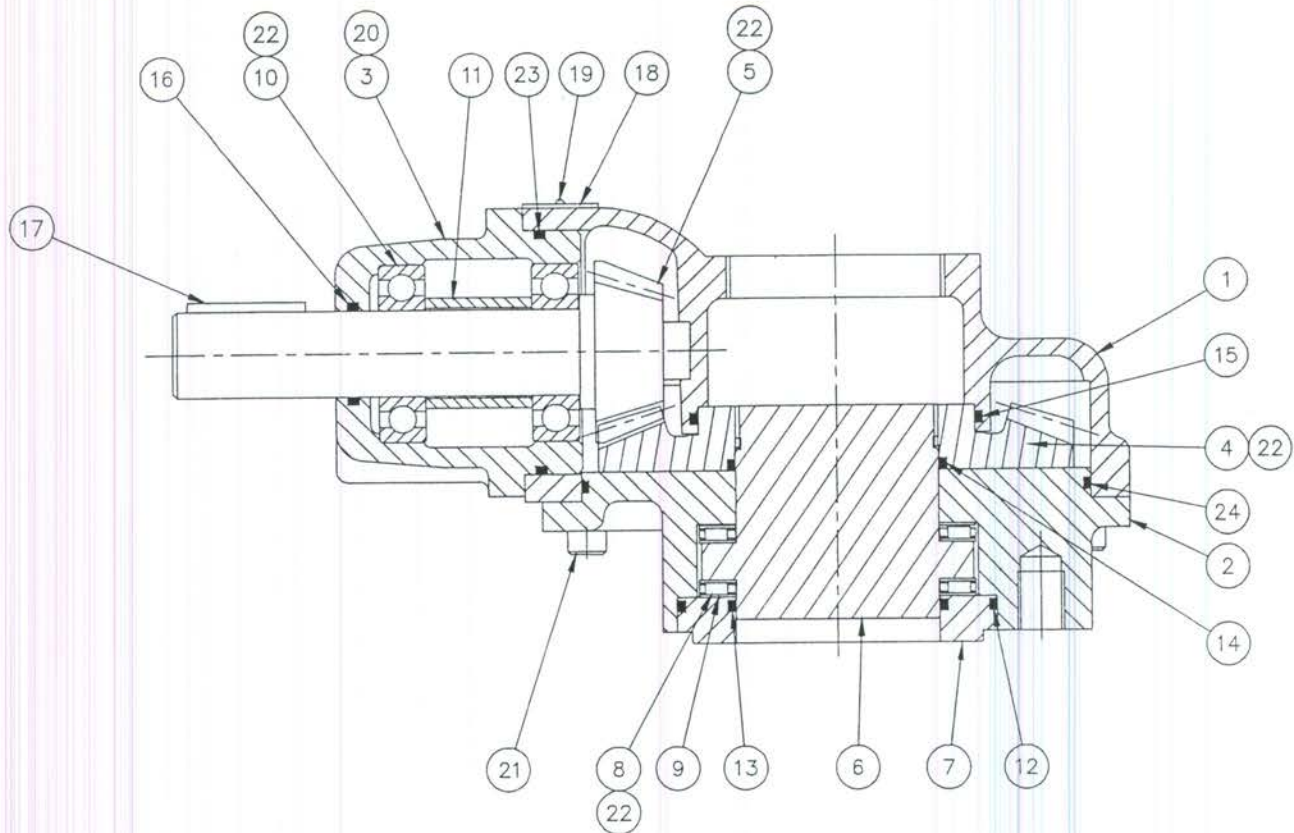

ITEM	DESCRIPTION	QUANTITY
1	GEARCASE	1
2	BASEPLATE	1
3	INPUT HOUSING	1
4	BEVEL GEAR	1
5	INPUT SHAFT & GEAR	1
6	OUTPUT SLEEVE	1 (IB, RAB & HOB only)
7	SPIGOT RING	1 (IB, RAB & HOB only)
* 8	THRUST BEARING	2 (IB, RAB & HOB only)
* 9	THRUST WASHER	4 (IB1-13, & HOB only)
*10	BALL BEARING	2 for IB & RAB (1 for HOB & NTB)
11	BEARING SPACER	1 (IB & RAB only)
*12	'O' RING	1 (IB, RAB & HOB only)
*13	'O' RING	1
*14	'O' RING	1 (IB, RAB & HOB only)
*15	'O' RING	1
*16	'O' RING	1
17	KEY	1
18	NAMEPLATE	1
19	NAMEPLATE RIVET	2
20	SOCKET HEAD CAP SCREW	4
21	SOCKET HEAD CAP SCREW	8
22	GREASE	
*23	'O' RING	1
*24	'O' RING	1

Note: items marked \* are the recommended spares holding for 5 years operation.



# INSTRUCTIONS FOR USE

## SPUR GEAR OPERATORS

Spur Range Specification:

Installation, Operating and Maintenance Instructions:

Assembly and Dismantling Instructions:

Spare Parts List and Recommended 5 Years Holding List:

Rotork Gears,  
Regina House,  
Bramley,  
Leeds,  
LS13 4ET,  
England.

## ROTORK GEARS SPUR RANGE SPECIFICATION

Component	Material Specification												
Gearcase	Cast Iron as standard, optional SG Iron, Carbon Steel or Stainless Steel.												
Baseplate	SG Iron as standard, optional Cast Iron, Carbon Steel or Stainless Steel.												
Input Housing	Cast Iron as standard, optional SG Iron, Carbon Steel or Stainless Steel.												
Output Gear	SG Iron as standard or Carbon Steel.												
Pinion Gear & Shaft	Carbon Steel as standard, optional Stainless Steel.												
Spigot Ring	SG Iron as standard, optional Cast iron.												
Screws	High Tensile Steel Metric Standard to BS3692 & 4168 as standard, optional Stainless Steel.												
Bearings	Input Shaft - Ball Type. Thrust Output – Needle roller type with thrust washers (with the exception of sizes 14, 16, 18, 19 & 20 which have cylindrical roller thrust bearings).												
Output Sleeve A1 (for non rising valve spindles)	Steel.												
Output Sleeve A2 (for rising valve spindles)	Aluminium Bronze.												
Finish	PA 24 Grey Primer (Standard). Primer and Enamel Gloss (Optional). Other finishes available on request.												
Lubricant	<table style="width: 100%; border: none;"> <tr> <td style="width: 50%; border: none;">CL-X2 (Standard) max temp 120°C:</td> <td style="width: 50%; border: none;">Ignition temperature &gt; 250°C</td> </tr> <tr> <td style="border: none;">LX-EP2 (High temp) max temp 160°C:</td> <td style="border: none;">Ignition temperature &gt; 250°C</td> </tr> <tr> <td style="border: none;">MHF-H1 (Food) max temp 177°C:</td> <td style="border: none;">Ignition temperature &gt; 260°C</td> </tr> <tr> <td style="border: none;">MO2 (Graphite) max temp 120°C:</td> <td style="border: none;">Flash point &gt; 200°C</td> </tr> <tr> <td style="border: none;">G110 (Nuclear) max temp 150°C:</td> <td style="border: none;">Flash point &gt; 200°C</td> </tr> <tr> <td style="border: none;">G130 (Nuclear) max temp 150°C:</td> <td style="border: none;">Flash point &gt; 200°C</td> </tr> </table>	CL-X2 (Standard) max temp 120°C:	Ignition temperature > 250°C	LX-EP2 (High temp) max temp 160°C:	Ignition temperature > 250°C	MHF-H1 (Food) max temp 177°C:	Ignition temperature > 260°C	MO2 (Graphite) max temp 120°C:	Flash point > 200°C	G110 (Nuclear) max temp 150°C:	Flash point > 200°C	G130 (Nuclear) max temp 150°C:	Flash point > 200°C
CL-X2 (Standard) max temp 120°C:	Ignition temperature > 250°C												
LX-EP2 (High temp) max temp 160°C:	Ignition temperature > 250°C												
MHF-H1 (Food) max temp 177°C:	Ignition temperature > 260°C												
MO2 (Graphite) max temp 120°C:	Flash point > 200°C												
G110 (Nuclear) max temp 150°C:	Flash point > 200°C												
G130 (Nuclear) max temp 150°C:	Flash point > 200°C												
Seals	<table style="width: 100%; border: none;"> <tr> <td style="width: 50%; border: none;">Nitrile (Standard) max temp 150°C:</td> <td style="width: 50%; border: none;">Ignition temperature &gt; 300°C</td> </tr> <tr> <td style="border: none;">Viton (High temp and Nuclear) max temp 200°C:</td> <td style="border: none;">Ignition temperature &gt; 315°C</td> </tr> <tr> <td style="border: none;">Fluorosilicone (Low temp) max temp 225°C:</td> <td style="border: none;">Ignition temperature &gt; 300°C</td> </tr> <tr> <td style="border: none;">Silicone sealant max temp 200°C:</td> <td style="border: none;">Ignition temperature &gt; 450°C</td> </tr> </table>	Nitrile (Standard) max temp 150°C:	Ignition temperature > 300°C	Viton (High temp and Nuclear) max temp 200°C:	Ignition temperature > 315°C	Fluorosilicone (Low temp) max temp 225°C:	Ignition temperature > 300°C	Silicone sealant max temp 200°C:	Ignition temperature > 450°C				
Nitrile (Standard) max temp 150°C:	Ignition temperature > 300°C												
Viton (High temp and Nuclear) max temp 200°C:	Ignition temperature > 315°C												
Fluorosilicone (Low temp) max temp 225°C:	Ignition temperature > 300°C												
Silicone sealant max temp 200°C:	Ignition temperature > 450°C												

Gearbox Detail	Gearbox Specification										
Gearbox design Life	850 hours ( 20 minutes a day for 7 years)										
Gears	Designed basically to BS436.										
Gearbox type	Indicated on the nameplate										
Gearbox ratio	Indicated on the nameplate										
Maximum output torque	Indicated in the Rotork Gears catalogue										
Maximum thrust	Indicated in the Rotork Gears catalogue										
Gearbox duty specification	Indicated on the nameplate										
Nameplate Explosion Marking and Category	According to 94/9/EC and indicated on the nameplate										
Maximum speed for the input shaft	350 rpm										
Maximum bending moment on the input flange	<table style="width: 100%; border: none;"> <tr> <td style="width: 50%; border: none;">F10:</td> <td style="width: 50%; border: none;">66Nm</td> </tr> <tr> <td style="border: none;">F14:</td> <td style="border: none;">178Nm</td> </tr> <tr> <td style="border: none;">F16:</td> <td style="border: none;">210Nm</td> </tr> <tr> <td style="border: none;">F25:</td> <td style="border: none;">700Nm</td> </tr> <tr> <td style="border: none;">F30:</td> <td style="border: none;">770Nm</td> </tr> </table>	F10:	66Nm	F14:	178Nm	F16:	210Nm	F25:	700Nm	F30:	770Nm
F10:	66Nm										
F14:	178Nm										
F16:	210Nm										
F25:	700Nm										
F30:	770Nm										
Maximum operating temperature	Indicated on the nameplate										
Gearbox weight	Indicated on the nameplate										

C.F. 14.08.03 issue 2

F:\EXEECO\GBOX\ENGINEER\ATEX\Instructions\Spur\Spur Specification.doc



# INSTALLATION, OPERATING AND MAINTENANCE INSTRUCTIONS FOR BEVELS AND SPURS GEAR OPERATORS

The Rotork Gears Spur and Bevel Range Specification sheets indicate the materials of construction and information for putting the equipment into service. The gearbox is marked according to 94/9/EC with the temperature class and explosion group on the equipment and this shall be observed when installing and operating the equipment. The user alone is responsible for the appropriate use of the gearbox in consideration of the basic conditions existing at the plant.

This range of gearboxes is supplied to suit the order requirements but, unless specifically requested at the ordering stage, the output sleeve will be supplied blank and must be machined to suit the equipment to be operated. NTB gearboxes do not have a removable output sleeve.

A thrust element retention device is normally fitted to the baseplate for transporting purposes and **MUST** be removed to access the output sleeve. The output sleeve can be easily removed from the gearbox by first removing the loose piece spigot ring from the baseplate. It is imperative that the thrust bearings in the output are re-assembled correctly, along with the output sleeve and the spigot ring - That is: models that use needle roller thrust bearings **MUST** have a thrust washer at each side of the needle race. A bearing / washer assembly **MUST** be fitted at each side of the output sleeve thrust shoulder. Models with taper roller bearings **MUST** be assembled with the bearings correctly orientated. All thrust elements and bearing cavities must be packed with grease of the correct specification.

## NOTES FOR MOUNTING TO THE VALVE

1. The valve spindle must be greased before assembly of the gearbox to the valve.
2. Thrust element retention device to be removed prior to assembly to the valve.
3. Do not pack the spindle cover tube with grease as this can lead to pressure build up in the gearbox.
4. Flanges to be sealed on assembly with silicone sealant.
5. Spindle cover tubes and plugs to be sealed with suitable sealant.

If the gearbox has been supplied with a handwheel, it is recommended that this be fitted to the gearbox before mounting on the valve. This will make it easier to rotate the gearing to pick up the start of a thread or key location.

On a keyed valve shaft, once the key and keyway are lined up, the gearbox can be lowered onto the mounting flange and bolted down.

On a screwed valve shaft, rotating the handwheel will cause the gearbox to screw itself down the spindle. Once in the correct position it can be bolted down.

For large gearboxes, IB8 to IB14 and IS7 to IS20, we recommend fitting the thrust elements onto the valve prior to fitting the gearbox. The spigot ring and one set of thrust washers and bearings can be placed onto the valve first, then the output sleeve can be screwed down or fitted onto the spindle key, depending on the valve spindle design. The second set of thrust washers and bearings are then fitted. The gearbox then can be lowered onto the valve, taking care that the splines in the output gear and output sleeve do not get damaged.

When bolting the valve to the gearbox we recommend using at least grade 8.8 fasteners, and these **MUST** be torque tightened dependent upon the grade and size used.

If an electric actuator is fitted to the gearbox, a suitable input adaptor will have been supplied. After mounting the actuator to the to the gearbox, the limit and torque switch settings must be made in accordance with the manufacturer's instructions. The maximum permitted bending moment on the input adaptor of the gearbox is indicated on the gearbox specification sheet.

## HANDLING

Combined valve, actuator and gearbox must **NOT** be slung from the gearbox.

## MAINTENANCE

All gear cavities are lubricated and sealed for life and the type of grease and seals used within the gearbox is indicated on the nameplate and shown in the material specification. The required maintenance intervals depend on the respective application and will therefore have to be determined by the user dependent on the conditions of use. Annual inspection of the gearbox is recommended, but under normal operating conditions no maintenance is required for the gearbox, but should the valve be taken out of service for overhaul, the gearbox baseplate may be removed and the grease renewed. The baseplate must be sealed using silicone sealant on re-assembly, unless fitted with an O ring. Below is a table for the recommended tightening of screws.

SCREW SIZE	HEXAGON HEAD GRADE 8.8		HEXAGON HEAD GRADE 8.8 WITH NORDLOCK WASHER		SOCKET HEAD GRADE 12.9		SOCKET HEAD GRADE 12.9 WITH NORDLOCK WASHER		DURLOK GRADE 12.9 SCREW GRADE 12 NUT	
	TORQUE TIGHTNESS (Nm)	TORQUE TIGHTNESS (lbsft)	TORQUE TIGHTNESS (Nm)	TORQUE TIGHTNESS (lbsft)	TORQUE TIGHTNESS (Nm)	TORQUE TIGHTNESS (lbsft)	TORQUE TIGHTNESS (Nm)	TORQUE TIGHTNESS (lbsft)	TORQUE TIGHTNESS (Nm)	TORQUE TIGHTNESS (lbsft)
M4	2	2	3	2	4	3	5	4		
M5	5	4	6	4	8	6	10	7	11	8
M6	9	6	10	8	14	11	17	13	19	14
M8	21	15	25	18	35	26	42	31	45	33
M10	41	30	49	36	69	51	83	61	86	64
M12	71	53	86	63	121	89	145	107	152	112
M16	177	131	213	157	299	221	359	265	372	274
M20	346	255	415	306	584	431	701	517	717	529
M24	598	441	718	529	1009	744	1211	893		
M30					2006	1480				
M36					3508	2587				

Note: Once fully torque tightened Durlok fasteners must not be re used on Nuclear gearboxes.  
Copy of QC 40-2

NB. All thrust elements and bearing cavities must be re-greased and refitted in the correct order.

## SPARES

Spare parts must be selected from the spare parts lists and a recommended spares holding for 5 years is shown on the spare parts list.

C.F. 29.05.03 issue 1

F:\EXECCO\GBOX\ENGINEER\ATEX\Instructions\Spur\Installation Instructions for Bevel-Spur.doc



## PROCEDURE FOR DISMANTLING / RE-ASSEMBLY OF SPUR GEAR OPERATORS

1. **PURPOSE:** To provide dismantling / re-assembly instructions.
2. **SCOPE:** Rotork Gears range of spur gearboxes
3. **DEFINITION:** Sequence of instructions to dismantle and re-assemble Rotork Gears spur gearboxes.
4. **PROCEDURE:** Refer to spare parts list for item numbers.

### 4.1 Dismantling

- 4.1.1 Remove the key (28) from the input shaft (8).
- 4.1.2 Remove the 4 off socket head cap screws (25), which secure the input housing (4) to the gearcase (1). The endcap, where used, can also be removed.
- 4.1.3 Remove the input housing from the gearcase complete with the input shaft, bearings (17) and the spacer (12) where applicable.
- 4.1.4 Remove the input shaft from the housing. Remove the input gear (9) and key (30) where applicable.
- 4.1.5 Remove the 8 off socket head cap screws (26), which secure the baseplate (2) to the gearcase.
- 4.1.6 Remove the baseplate from the gearcase. The output gear (5) will probably remain on the splines of the output sleeve (11).
- 4.1.7 Remove the output gear from the output sleeve and the output hub (5) from the output gear where applicable.
- 4.1.8 Remove the spigot ring (10), bearings (16), thrust washers (15) and output sleeve from the baseplate..
- 4.1.9 Remove the hexagonal head screw (27) where applicable and remove idler shaft (6) from the gearcase.
- 4.1.10 Remove the idler gear (7) from the gearcase and remove the bearings (18) from the idler gear.
- 4.1.11 The input gear can be removed from the gearcase if not removed in 4.1.4.

### 4.2 Re-assembly

- 4.2.1 Position the input gear in the gearcase if removed in 4.1.10.
- 4.2.2 Grease and fit the bearings into the idler gear and position in the gearcase.
- 4.2.3 Fit the 'o' ring (23) to the idler shaft and re-fit the idler shaft into the gearcase and the idler gear. Re-secure the hexagonal head screw where applicable.
- 4.2.4 Ensure that the output gear and baseplate are free from dirt and bruising and then fit the 'o' rings (21 and 22) to the output gear.
- 4.2.5 Re-pack the gearcase with grease.
- 4.2.6 Fit the output gear and output hub, where applicable, into the gearcase and locate with the idler gear.
- 4.2.7 Fit the 'o' ring (31) to the baseplate and re-secure the baseplate to the gearcase using the existing screws (26) by using a diagonal tightening movement.
- 4.2.8 Reassemble the input housing sub assembly with the input shaft, input gear, key spacer and bearings ensuring are parts are clean and repack the housing with grease. Fit 'o' rings (13 and 24) to the housing.
- 4.2.9 Re-fit the input housing sub-assembly into the gearcase ensuring that the input gear locates with the idler gear.
- 4.2.10 Secure the input housing to the gearcase with the existing screws (25) using a diagonal tightening movement.
- 4.2.11 Re-fit the key to the input shaft.
- 4.2.12 Apply grease to the thrust bearings and washers and re assemble the output sleeve and spigot ring assembly into the baseplate. Ensure that the 'o' ring (21) remains undamaged.
- 4.2.13 Test the gearbox for free rotation.

## 5. DOCUMENTATION

Spare parts list for range of spur gear actuators: Spur Part List.doc  
Torque tightening figures. Document No QC 40-2

# SPARE PARTS LIST FOR RANGE OF SPUR GEAR ACTUATORS

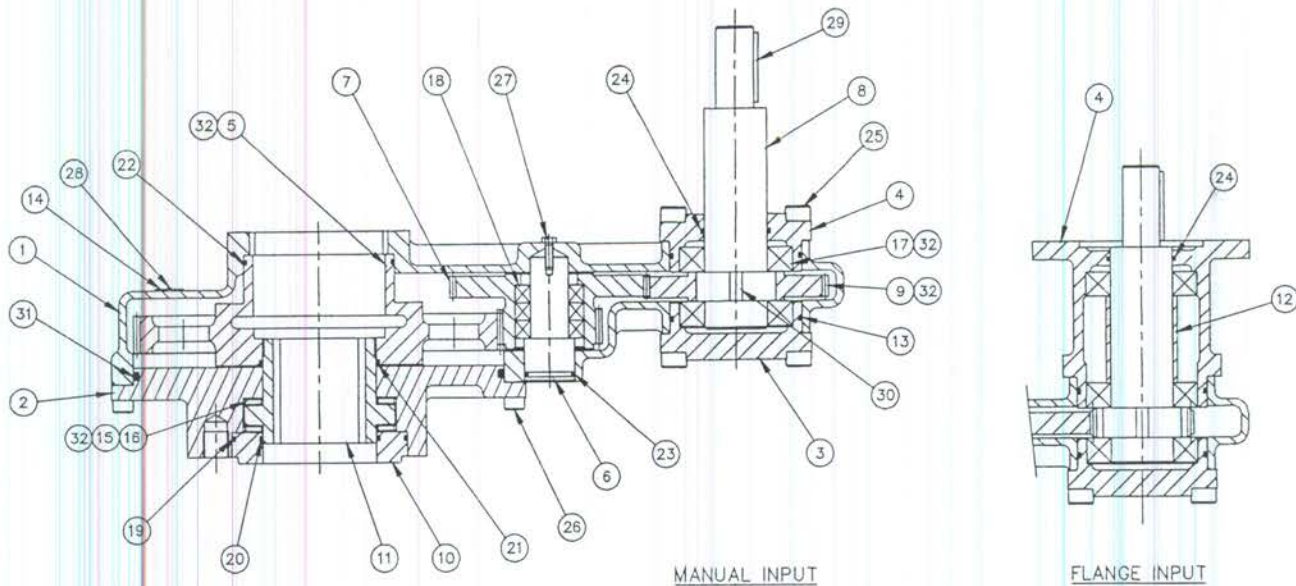

ITEM	DESCRIPTION	QUANTITY
1	GEARCASE	1
2	BASEPLATE	1
3	ENDCAP (BLANK)	1 (not used on IS2 to IS5)
4	INPUT HOUSING	1
5	OUTPUT GEAR	1 (IS15-20 has additional Output Hub)
6	IDLER SHAFT	1 (IS6, 7, 10-20 has additional Spacer)
7	IDLER GEAR	1
8	INPUT SHAFT	1 (can be combined with items 9 & 30)
9	INPUT GEAR	1 (can be combined with items 8 & 30)
10	SPIGOT RING	1
11	OUTPUT SLEEVE	1
12	SPACER	1
13	O RING	2 (1 for IS2 to IS5)
14	NAMEPLATE	1
*15	THRUST WASHER	4 (not used on IS14, 16, 18, 19, 20)
*16	THRUST BEARING	2
*17	BALL BEARING	2 (Manual input) or 3 (Flange Input)
*18	BALL BEARING	2 (2-7), 3 (8-11), 4 (12-16), 6 (17-20)
*19	O RING	1
*20	O RING	1
*21	O RING	1
*22	O RING	1
*23	O RING	1
*24	O RING	1
25	SOCKET HEAD CAP SCREW	8 (4 for IS2 to IS5)
26	SOCKET HEAD CAP SCREW	8
27	HEXAGON HEAD SCREW	1 for IS6 & IS7 only
28	RIVET	2
29	KEY	1
30	KEY	1 (can be combined with items 8 & 9)
*31	O RING	1
32	GREASE	

Note: Items marked \* are the recommended spares holding for 5 years operation.





Clow Valve Co.

902 South 2nd Street  
Oskaloosa, IA 52577

Telephone: 641 673-8611  
Fax: 641 673-8269

## CLOW RESILIENT WEDGE VALVES

### TEN YEAR LIMITED WARRANTY

Clow Valve Company warrants that its R/W valves will be free from defects in material and workmanship under normal and customary use and maintenance for a period of **ten (10)** years from the date of purchase, provided the valve is installed and maintained according to Clow instruction, and applicable codes. The foregoing warranty does not cover failure of any part or parts from external forces, including but not limited to earthquake, vandalism, vehicular or other impact, and application of excessive torque to the operating mechanism or frost heave.

Should any Clow Valve Company part or parts fail to conform to the foregoing warranty, Clow shall, upon prompt written notice thereof, repair or replace, F.O.B. point of manufacture, such defective part or parts. Purchaser shall, if requested, return the part or parts to Clow, transportation prepaid. Purchaser shall bear all responsibility and expense incurred for removal, reinstallation and shipping in connection with any part supplied under the foregoing warranty.

**THE FOREGOING WARRANTY IS IN LIEU OF AND EXCLUDES ALL OTHER WARRANTIES NOT EXPRESSLY SET FORTH HEREIN, WHETHER EXPRESS OR IMPLIED BY OPERATION OF LAW OR OTHERWISE, INCLUDING BUT NOT LIMITED TO ANY WARRANTIES OF MERCHANT ABILITY OR FITNESS. IN NO EVENT SHALL CLOW VALVE COMPANY BE RESPONSIBLE OR LIABLE FOR ANY INCIDENTAL OR CONSEQUENTIAL LOSSES, DAMAGES OR EXPENSES.**