

# CLOW CANADA

## Brigadier Fire Hydrant Specification



---

**McAvity**

**CLOW**

A division of Canada Pipe Company Ltd.

**CONCORD**

# **CLOW CANADA - M67B BRIGADIER**

## **FIRE HYDRANT SPECIFICATION**

### **TESTING AND DESIGN SPECIFICATIONS (PER AWWA C502 / NSF /ULC & FM)**

1. Hydrant shall be manufactured in accordance with AWWA C502 latest revision
2. Hydrant Has been certified by **UL** in accordance with the **ANSI/NSF 61 and ANSI/NSF 372** (LEAD CONTENT VERIFICATION OF PRODUCTS INCONTACT WITH POTABLE WATER)
3. Hydrant shall be designed for 250 *PSI* working pressure and tested to 500 *PSI* hydrostatic pressure.
4. Hydrant shall be rated for 250 *PSI*. **FM** working pressure and 200 *PSI*. **ULC** working pressure.
5. Hydrant shall be a compression type, dry barrel design with centre operating stem construction.
6. The O-ring seating surface on the upper stem shall be constructed of stainless steel.
7. Epoxy coating to be applied to interior and exterior of hydrant shoe for corrosion protection.
8. Hydrant shall be manufactured with operating nut and integral thrust collar made of bronze. A Delrin washer bearing shall be located above thrust collar for ease of hydrant operation.
9. Hydrant shall have a lower valve assembly that fully encapsulates the lower operating rod threads. This allows for increased corrosion resistance and ease of disassembly.
10. Intermediate section shall be ductile iron. (AWWA C110 – 08)

### **STANDARD HYDRANT FEATURES**

1. Body style: Round
2. Hydrant shall have an internally lubricated bronze operating nut with O-ring seals. Operating nut shall be of the Hydra-lube<sup>TM</sup> design to ensure self lubrication during operation.
3. Hydrant hose nozzles shall be mechanically locked into place by an external allen screw, and have O-ring seals.
4. Hydrant Lower rod shall be 1-1/4" in sq.
5. Hydrant shall have a main valve opening of 5-1/4".
6. Hydrant shall be a traffic model, complete with safety flanges and stem coupling. Upper body can be rotated 360 degrees to adjust pumper direction.
7. Hydrant shall be manufactured with a lower valve plate that bottoms out in the shoe for maximum opening.
8. Hydrant shall be backed by manufacturer's 12 year limited warranty
9. Hydrant shall be the Clow Canada Brigadier as manufactured by Clow Canada.

## **OPTIONAL HYDRANT FEATURES**

1. 2 hose or 2 hose & one pumper upper body
2. AVAILABLE INLETS:
  - 150mm (6") Mechanical Joint (ANSI A-21.11)
  - 150mm (6") Online chamber flanged (ANSI B16.1 Class 125) for (AWWA C110 – 08) tee
  - 200mm (8") Mechanical Joint (ANSI A-21.11)
  - 200mm (8") Online chamber flanged (ANSI B16.1 Class 125) for (AWWA C110 – 08) tee
  - 150mm (6") flanged (ANSI B16.1 Class 125)
  - 150mm (6") flanged (ANSI B16.1 Class 250)
  - 150mm (6") Tyton (AWWA C111/A21.11)
3. All standard inlets available in CAST IRON ASTM A126 Class B  
Or Ductile Iron ASTM A536 (65-45-12)
4. Hydra-lube operating nut – see standard shapes on submittal drawing
5. Two 65mm (2.5") hose nozzles - threads on nozzle ends to suit national, provincial or municipal standard or STORZ quick connect
6. One 114mm (4.5") pumper nozzle - threads on nozzle ends to suit national, provincial or municipal standard
7. 100mm (4") or 125mm (5") STORZ quick connect pumper nozzle.
8. Nozzle caps to suit – see standard shapes on submittal drawing.
9. Two external .375" NPT plugs in inlet @ 180 degrees / one internal .25" NPT plug
10. Hose & pumper nozzle cap chains
11. Hydrants painted / coated to suit national, provincial or municipal standard per AWWA C502 / AWWA C550

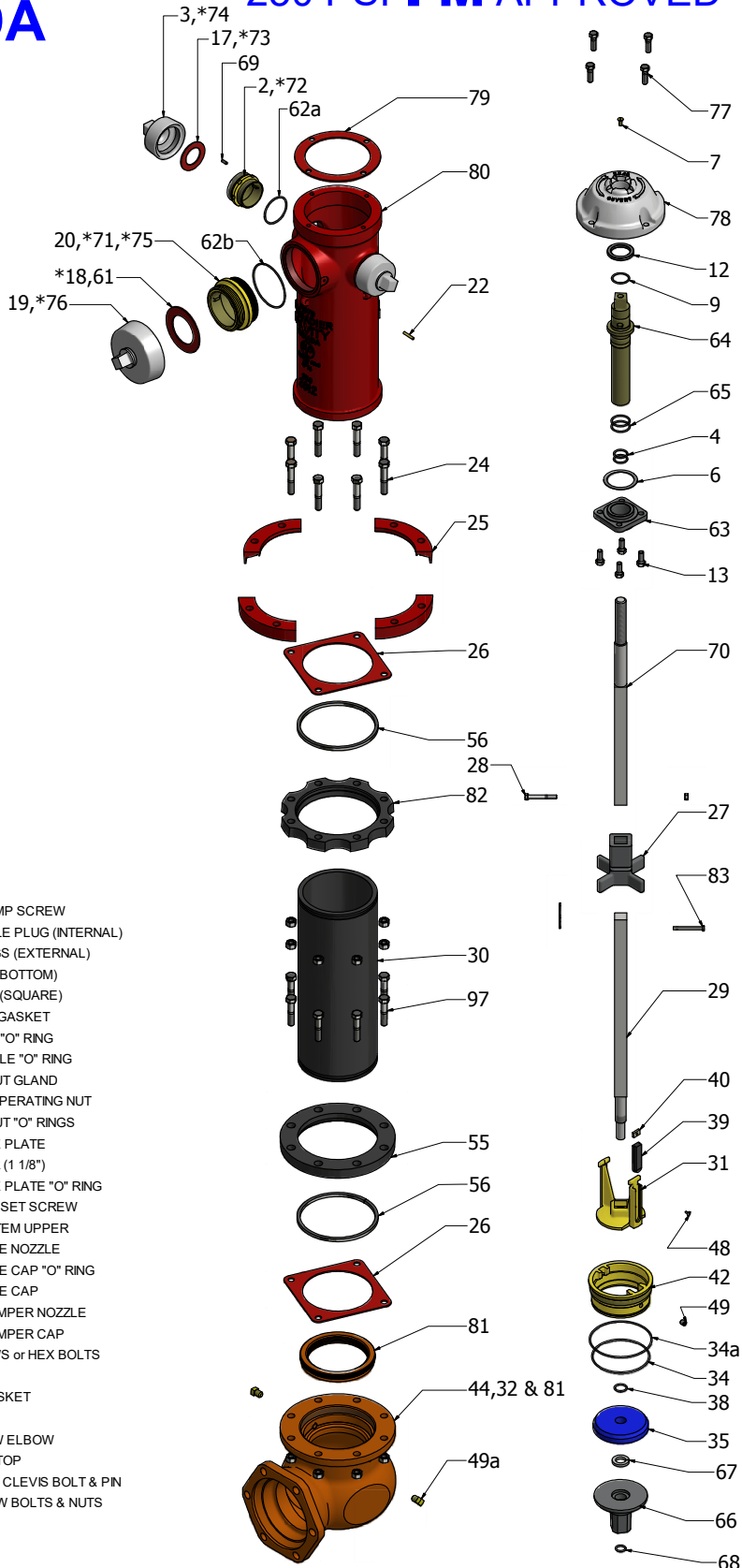
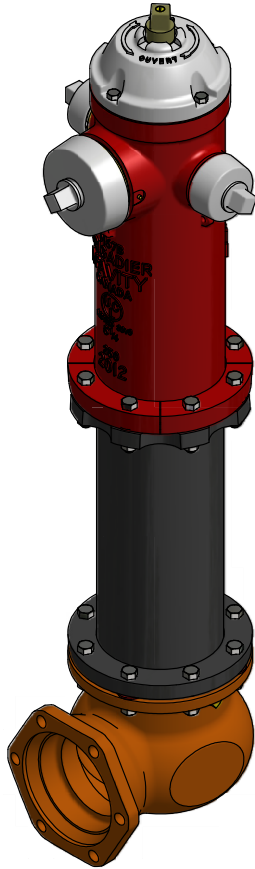

**DESCRIPTION**

- 2 HOSE NOZZLE
- 3 HOSE NOZZLE CAP
- 4 HOUSING STEM "O" RINGS
- 6 HOUSING JOINT GASKET
- 7 OIL HOLE SCREW
- 9 OPERATING NUT "O" RING
- 12 OPERATING NUT BEARING
- 13 HEX BOLT (1/2" x 1 1/4")
- 17 HOSE CAP GASKET
- \*18 STORZ 100 PUMPER CAP "O" RING
- 19 PUMPER NOZZLE CAP
- 20 PUMPER NOZZLE
- 22 PUMPER NOZZLE PIN
- 24 INTERSECTION BOLTS & NUTS
- 25 SAFETY FLANGE (4 SEGMENTS)
- 26 INTERSECTION GASKET
- 27 SAFETY COUPLING
- 28 SAFETY COUPLING BOLT & NUT
- 29 OPERATING STEM LOWER
- 30 INTERMEDIATE SECTION
- 31 DRIP VALVE
- 32 DRAIN HOLE LINING C/W ELBOW
- 34 SEAT "O" RING BOTTOM
- 34a SEAT "O" RING TOP
- 35 MAIN VALVE DISC
- 38 MAIN VALVE "O" RING
- 39 DRIP VALVE FACING
- 40 HOLDING CLAMP
- 42 MAIN VALVE SEAT
- 44 ELBOW (STATE INLET REQUIRED)

**DESCRIPTION**

- 48 HOLDING CLAMP SCREW
- 49 1/4" DRAIN HOLE PLUG (INTERNAL)
- 49a 3/8" PIPE PLUGS (EXTERNAL)
- 55 PIPE FLANGE (BOTTOM)
- 56 RETAINING RING (SQUARE)
- 61 PUMPER CAP GASKET
- 62a HOSE NOZZLE "O" RING
- 62b PUMPER NOZZLE "O" RING
- 63 OPERATING NUT GLAND
- 64 HYDRALUBE OPERATING NUT
- 65 OPERATING NUT "O" RINGS
- 66 LOWER VALVE PLATE
- 67 LOCKWASHER (1 1/8")
- 68 LOWER VALVE PLATE "O" RING
- 69 HOSE NOZZLE SET SCREW
- 70 OPERATING STEM UPPER
- \*72 STORZ 65 HOSE NOZZLE
- \*73 STORZ 65 HOSE CAP "O" RING
- \*74 STORZ 65 HOSE CAP
- \*75 STORZ 100 PUMPER NOZZLE
- \*76 STORZ 100 PUMPER CAP
- 77 ALLEN SCREWS or HEX BOLTS
- 78 BODY CAP
- 79 BODY CAP GASKET
- 80 BODY
- 81 SEAT RING C/W ELBOW
- 82 PIPE FLANGE TOP
- 83 SAFETY CPLG. CLEVIS BOLT & PIN
- 97 PIPE TO ELBOW BOLTS & NUTS

\*OPTIONAL PARTS



## M67 BRIGADIER HYD. WITH BOLTED BODY CAP MATERIAL LIST

REF No	DESCRIPTION	MATERIAL	REF No	DESCRIPTION	MATERIAL
2	HOSE NOZZLE	COPPER ALLOY	49	DRAIN HOLE PLUG	BRASS
3	HOSE NOZZLE CAP	CAST IRON	50	INTERSECTION EXTENSION	DUCTILE IRON
4	HOUSING STEM "O" RINGS	BUNA - N	51	EXTENSION STEM	STEEL
5	HOSE CAP CHAIN & "S" HOOK	STEEL ZINC PLATED	52	ALIGNMENT COUPLING	CAST IRON
6	HOUSING JOINT GASKET	COMPRESSED NON-ASBESTOS	53	EXTENSION STEM BOLTS & NUTS (3/8" x 3")	STEEL ZINC PLATED
7	OIL HOLE SCREW	BRASS	55	PIPE FLANGE ( BOTTOM )	CAST IRON
9	OPERATING NUT "O" RING	BUNA - N	56	RETAINING RING (SQUARE)	STEEL ZINC PLATED
12	OPERATING NUT BEARING	DELRIN	57	MONITOR BOLT & NUT ( 5/8" x 2 3/4" )	STEEL ZINC PLATED / 18-8 SS
13	CAP SCREW (1/2" x 1 1/4")	STEEL ZINC PLATED	58	MONITOR ELBOW	CAST IRON
17	HOSE CAP GASKET	RED RUBBER	59	MONITOR GASKET	RED RUBBER
18	STORZ 100 PUMPER CAP "O" RING	BUNA - N	61	PUMPER CAP GASKET	RED RUBBER
19	PUMPER NOZZLE CAP	CAST IRON	62a	HOSE NOZZLE "O" RING	BUNA - N
20	PUMPER NOZZLE	COPPER ALLOY	62b	PUMPER NOZZLE "O" RING	BUNA - N
21	PUMPER CAP CHAIN & "S" HOOK	STEEL ZINC PLATED	63	OPERATING NUT RETAINING GLAND	CAST IRON
22	PUMPER NOZZLE PIN	BRASS	64	HYDRALUBE OPERATING NUT	COPPER ALLOY
24	INTERSECTION BOLTS & NUTS	STEEL ZINC PLATED / 18-8 SS	65	OPERATING NUT "O" RINGS (RETAINING GLAND)	BUNA - N
25	SAFETY FLANGE (SEGMENTS)	CAST IRON	66	LOWER VALVE PLATE	CAST IRON
26	INTERSECTION GASKET	RED RUBBER	67	LOCKWASHER (1 1/8")	18-8 STAINLESS STEEL
27	SAFETY COUPLING	CAST IRON	68	LOWER VALVE PLATE "O" RING	BUNA - N
28	SAFETY COUPLING BOLT & NUT (3/8"x 3")	STEEL ZINC PLATED	69	HOSE NOZZLE SET SCREW (1/4" x 3/4")	18-8 STAINLESS STEEL
29	OPERATING STEM LOWER	STEEL	70	OPERATING STEM UPPER	416 MX STAINLESS STEEL
30	INTERMEDIATE SECTION	DUCTILE IRON	71	STORZ 100 PUMPER NOZZLE	STAINLESS STEEL
31	DRIP VALVE	COPPER ALLOY	72	STORZ 65 HOSE NOZZLE	COPPER ALLOY
32 *	DRAIN HOLE LINING	BRASS	73	STORZ 65 HOSE CAP "O" RING	BUNA - N
34a	SEAT "O" RING (TOP)	BUNA - N	74	STORZ 65 HOSE CAP	CAST IRON
34	SEAT "O" RING (BOTTOM)	BUNA - N	75	STORZ 100 PUMPER NOZZLE	COPPER ALLOY
35	MAIN VALVE DISC	RUBBER OR POLYURETHANE	76	STORZ 100 PUMPER CAP	CAST IRON
38	MAIN VALVE "O" RING	BUNA - N	77	BODY CAP ALLEN SCREWS OR HEX BOLTS	18-8 STAINLESS STEEL
39	DRIP VALVE FACING	RUBBER	78	BODY CAP	CAST IRON
40	HOLDING CLAMP	PLASTIC	79	BODY CAP GASKET	RED RUBBER
42	MAIN VALVE SEAT	COPPER ALLOY	80	BODY	CAST IRON
44 *	ELBOW (STATE INLET REQUIRED)	CAST IRON	81 *	SEAT RING	COPPER ALLOY
45 **	GUIDE PLATE ASSEMBLY	STEEL	82	PIPE FLANGE ( TOP )	CAST IRON
46 **	INTERIOR WRENCH	STEEL	83	SAFETY COUPLING CLEVIS BOLT & PIN	STEEL ZINC PLATED
47	HOLDING NUT	COPPER ALLOY	97	PIPE TO ELBOW BOLTS& NUTS	STEEL ZINC PLATED / 18-8 SS
48	HOLDING CLAMP SCREW	BRASS			

\* PERMANENTLY ASSEMBLED PARTS SUPPLIED WITH ELBOW REF. No. 44

\*\* SUPPLIED AS ASSEMBLY ONLY

# CLOW CANADA - M67B & M93B BRIGADIER HYDRANT - 250 PSI FM APPROVED

## HYDRANT BODY STYLES

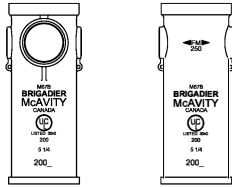

2 HOSE  
1 PUMPER BODY



2 HOSE  
BODY

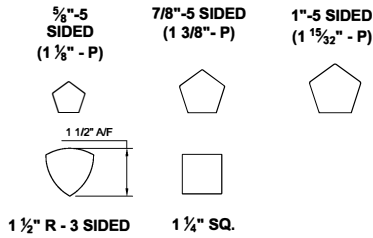

AVAILABLE OPERATING NUTS

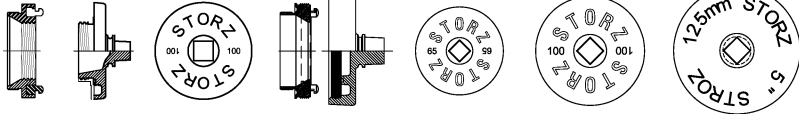

### STORZ OPTIONS

STORZ 65mm HOSE NOZZLE, STORZ 100mm PUMPER NOZZLE, STORZ 125mm PUMPER NOZZLE & STORZ 100mm 316 STAINLESS STEEL

## AVAILABLE HYDRANT END CONNECTIONS

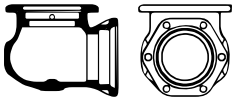

6" M.J. CAST IRON ELBOW

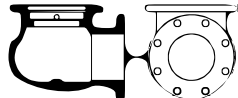

6" FLANGED CAST IRON ELBOW



6" CAST IRON  
ON-LINE CHAMBER

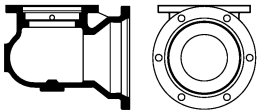

8" M.J. CAST IRON ELBOW

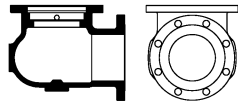

6" 150 LB FLANGED DUCTILE  
IRON RAISED FACE ELBOW



8" CAST IRON  
ON-LINE CHAMBER

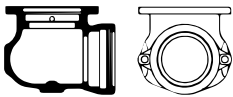

6" PUSH-ON CAST IRON ELBOW

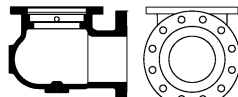

6" 250 LB FLANGED DUCTILE  
IRON RAISED FACE ELBOW

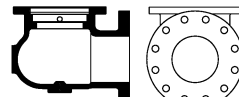

6" 250 LB FLANGED DUCTILE IRON  
FLAT FACE ELBOW

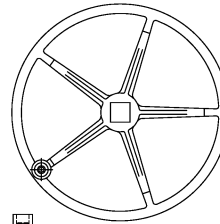

OPTIONAL  
HANDWHEEL & SPINNER

PERMANENT 3/8" SQUARE  
HEAD BRASS PIPE PLUG  
(2) FACTORY INSTALLED  
REMOVABLE / INSERTABLE  
1/4" NPT BRASS PLUG

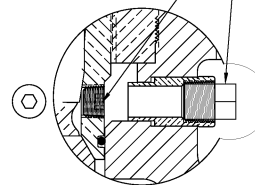

METHOD OF PLUGGING DRAIN HOLE  
IN MAIN VALVE SEAT / INLET

DETAIL "A"

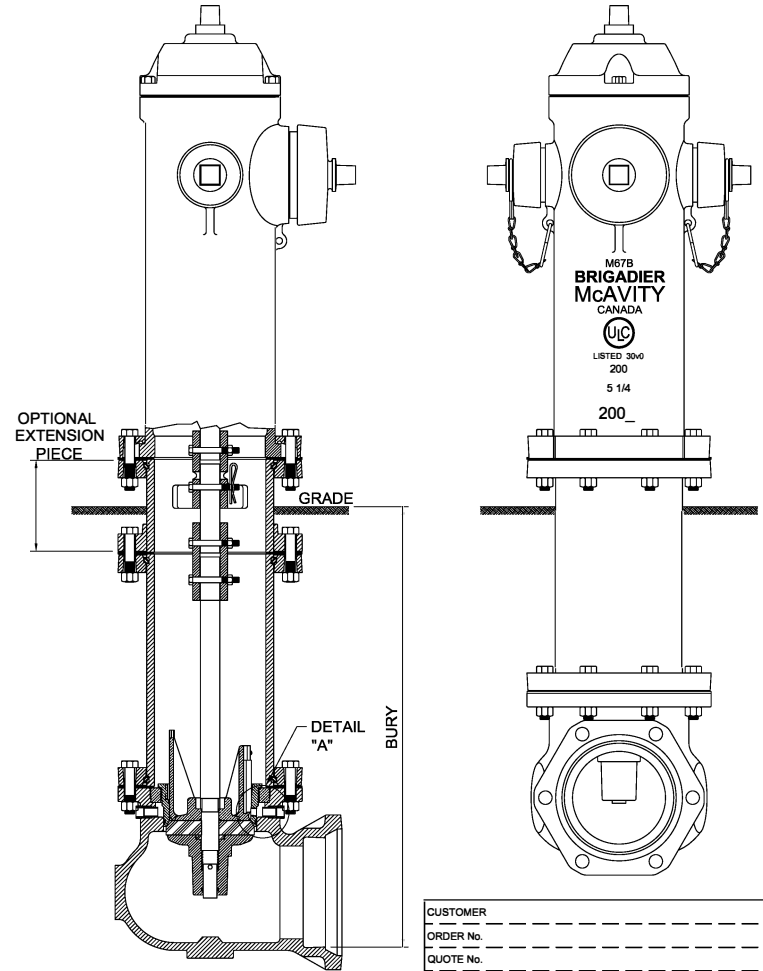

CUSTOMER	_____
ORDER No.	_____
QUOTE No.	_____
JOB	_____
M67B/M93B "BRIGADIER" COMPRESSION TYPE HYDRANT WITH BOLTED BODY CAP	
<b>CLOW CANADA</b>	
AUGUST 2014	DWG. No. McM-551504

DO NOT SCALE

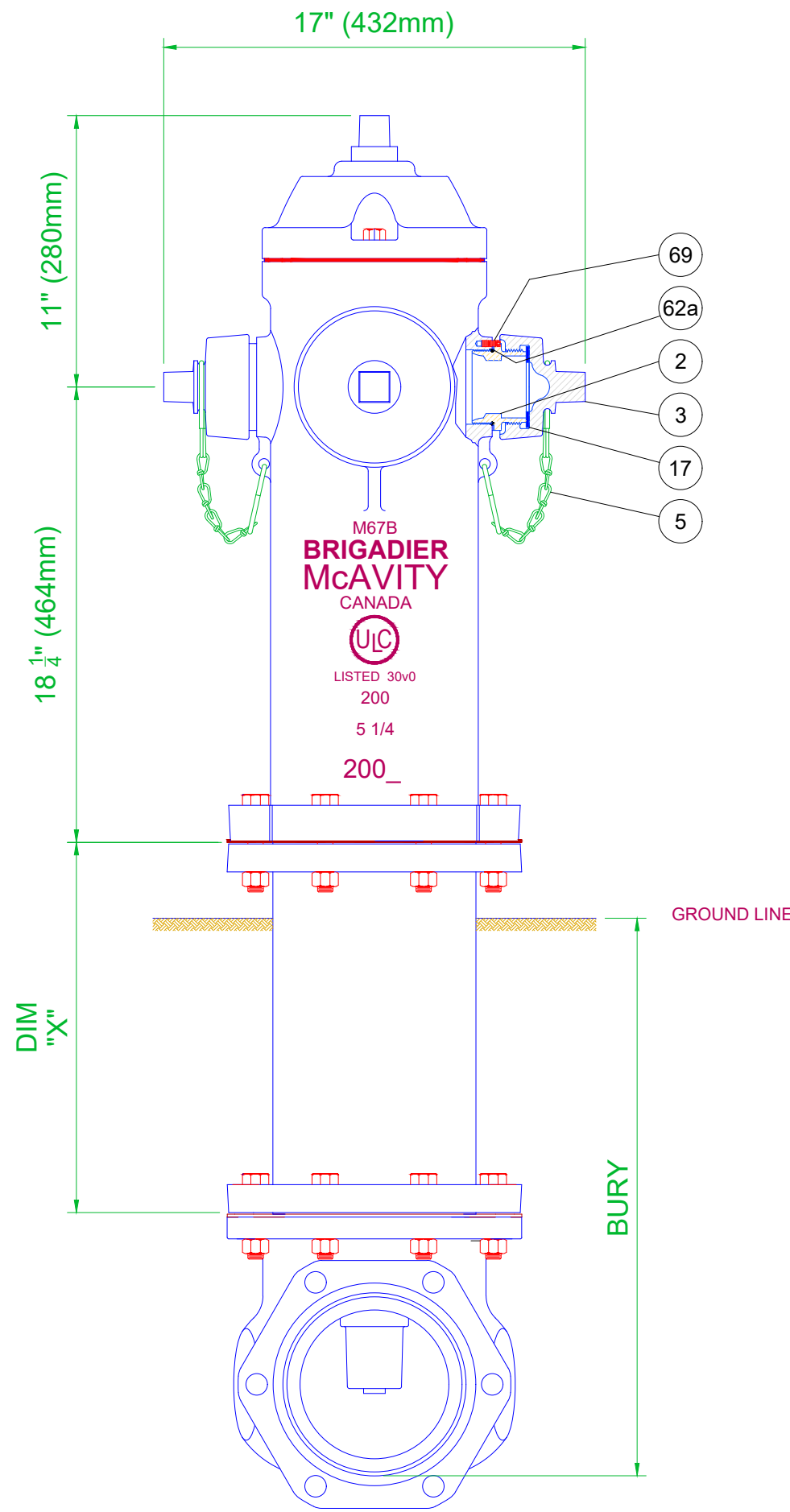
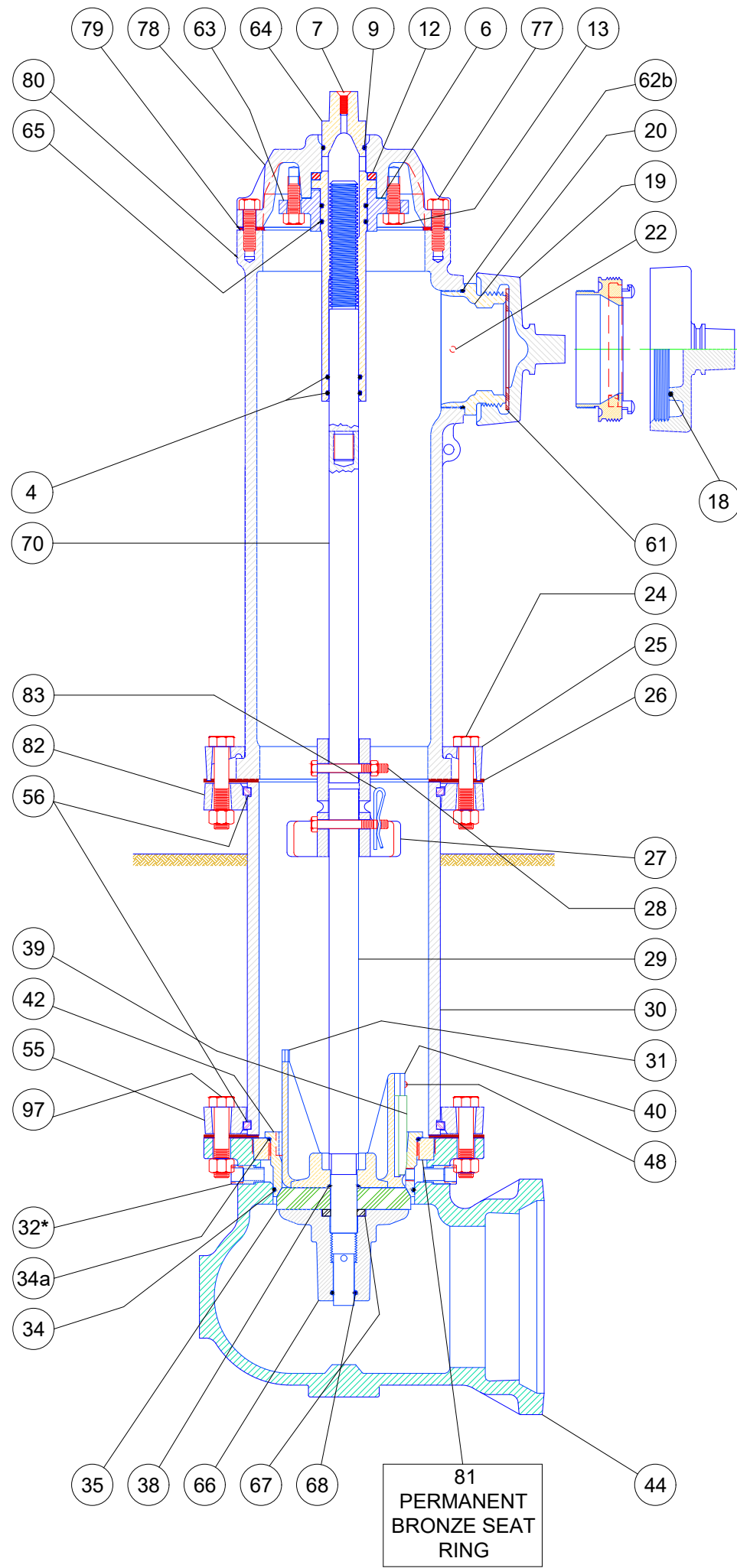

Note: DIM "X" IS 9" (229mm)  
LESS THAN BURY REQUIRED

REF No.	Description	REF No.	Description
2	Hose Nozzle	38	Main Valve "O" Ring
3	Hose Nozzle Cap	39	Drip Valve Facing
4	Housing Stem "O" Rings	40	Holding Clamp
5	Hose Cap Chain & Hook	42	Main Valve Seat
6	Housing Joint Gasket	44	Elbow
7	Oil Hole Screw	48	Holding Clamp Screw
9	Operating Nut "O" Ring	55	Pipe Flange (Bottom)
12	Operating Nut Bearing	56	Retaining Ring (Square)
13	Cap Screw (1/2" x 1 1/4")	61	Pumper Cap Gasket
17	Hose Cap Gasket	62a	Hose Nozzle "O" Ring
18	Storz 100 Pumper Cap "O" Ring	62b	Pumper Nozzle "O" Ring
19	Pumper Nozzle Cap	63	Operating Nut Retaining Gland
20	Pumper Nozzle	64	Hydralube Operating Nut
22	Pumper Nozzle Pin	65	Operating Nut "O" Rings (Retaining Gland)
24	Intersection Bolts & Nuts	66	Lower Valve Plate
25	Safety Flange (Segments)	67	Lockwasher (1 1/8")
26	Intersection Gasket	68	Lower Valve Plate "O" Ring
27	Safety Coupling	69	Hose Nozzle Set Screw (1/4" x 3/4")
28	Safety Coupling Bolt & Nut (3/8"x3")	70	Operating Stem Upper
29	Operating Stem Lower	77	Body Cap Allen Screws or Hex Bolts
30	Intermediate Section	78	Body Cap
31	Drip Valve	79	Body Cap Gasket
32	Drain Hole Lining	80	Body
34a	Seat "O" Ring (Top)	82	Pipe Flange (TOP)
34	Seat "O" Ring (Bottom)	83	Safety Coupling Clevis Bolt & Pin
35	Main Valve Disc	97	Pipe to Elbow Bolts & Nuts

CUSTOMER \_\_\_\_\_  
 ORDER No. \_\_\_\_\_  
 QUOTE No. \_\_\_\_\_  
 JOB \_\_\_\_\_

DRAWN Adam Smith	M67B HYDRANT WITH 6" MJ ELBOW
CHECKED	
EXAMINED	<b>CLOW CANADA</b>
NOTED	
APPROVED	SCALE: 1/2" SIZE: DATE: AUG 18, 2022
	DRAWING No. McM-067076

REF. NOS.

AUG 18 2022 A.S

DO NOT SCALE

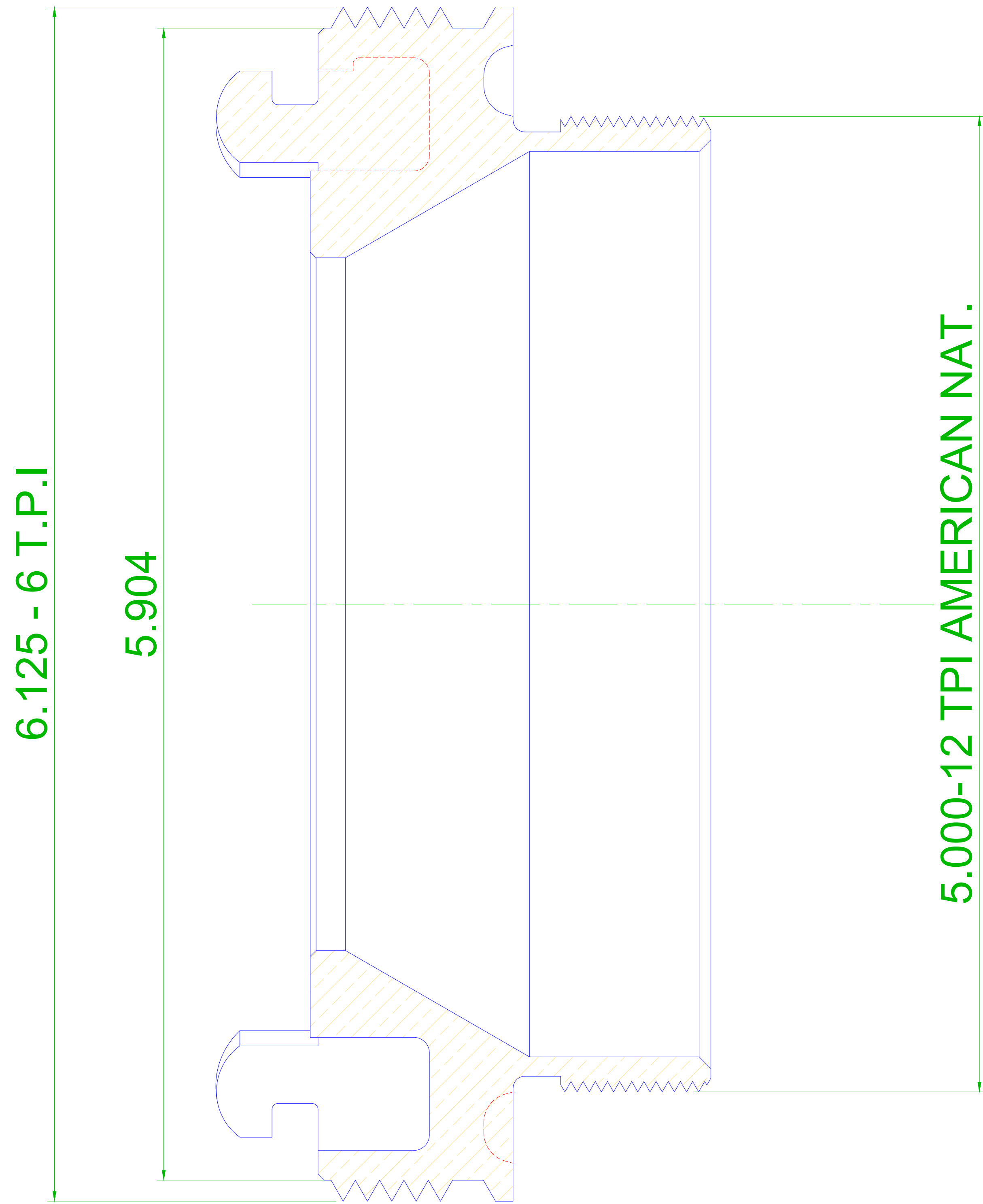

REF. NOS.

ZG STORZ 100mm  
PUMPER NOZZLE

**CLOW CANADA**

SCALE FULL SIZE DATE APR. 22/2009



REF. NOS. McA-545802 REV T

DO NOT SCALE

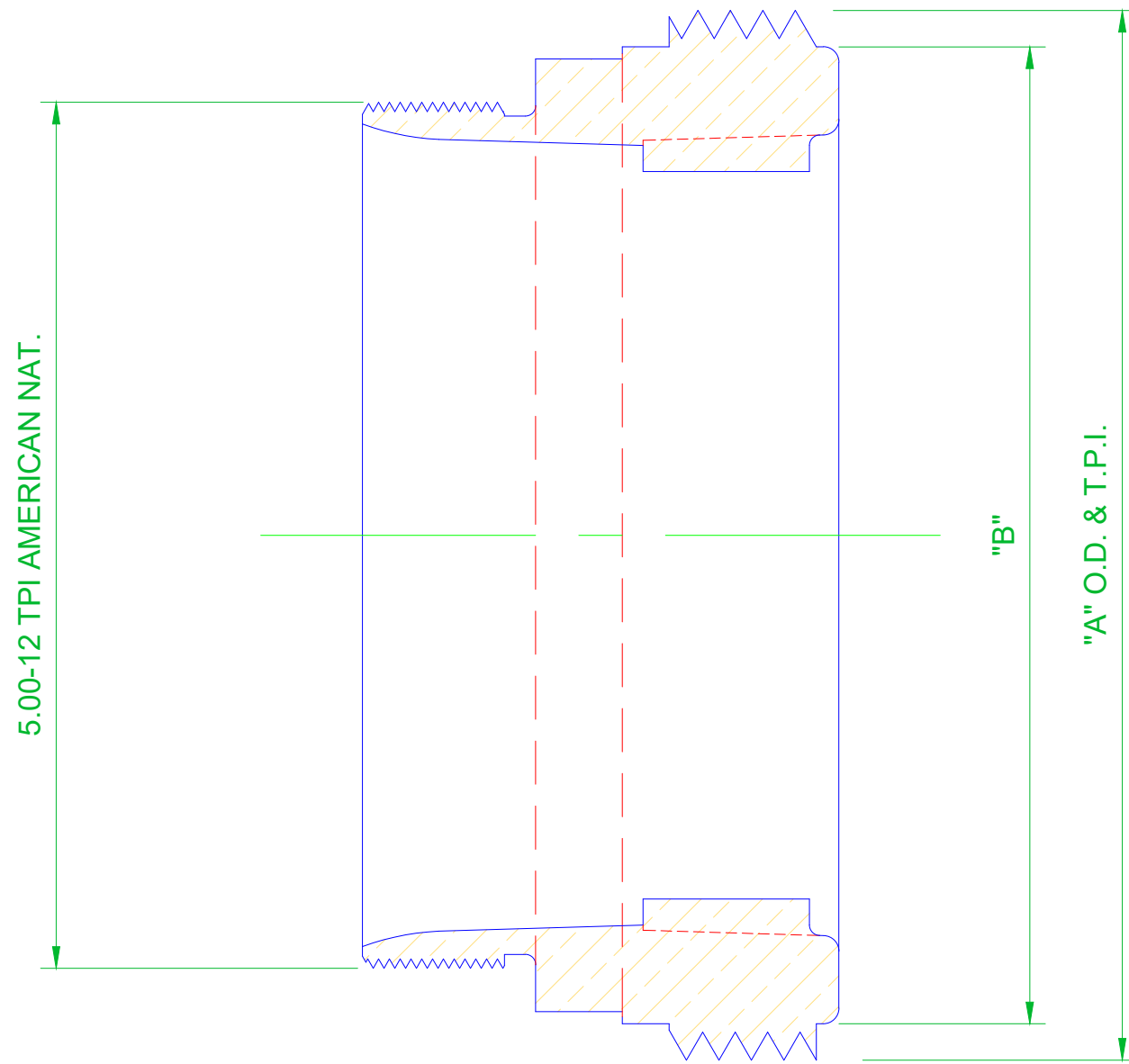

STAMPING LETTER	'A' O.D. & T.P.I.
VH	5.84 - 8
NF	5.43 - 6
PF	5.47 - 6
SF	5.84 - 6
XE	5.84 - 5
YE	5.90 - 5
ND	5.62 - 4
OD	5.71 - 4
PD - Edmonton	5.72 - 4
SD - National	5.75 - 4
WD - Seagrave	6.06 - 4
YD	6.25 - 4
VD	6.00 - 4
JF - WC US	4.84 - 6
EF - BC STD	4.59 - 6
OH - Saskatoon	4.93 - 8
FE - Sherbrooke	4.75 - 5

WEIGHT
MATERIAL
BRONZE ASTM B-584 ALLOY C84400 B-584 ALLOY C87850
FINISH

DRAWN	<h1>M67 PUMPER NOZZLE LARGE</h1> <h2>CLOW CANADA</h2>
CHECKED	
EXAMINED	
NOTED	
APPROVED	SCALE <b>FULL SIZE</b> DATE <b>APR. 28/2008</b>

DO NOT SCALE

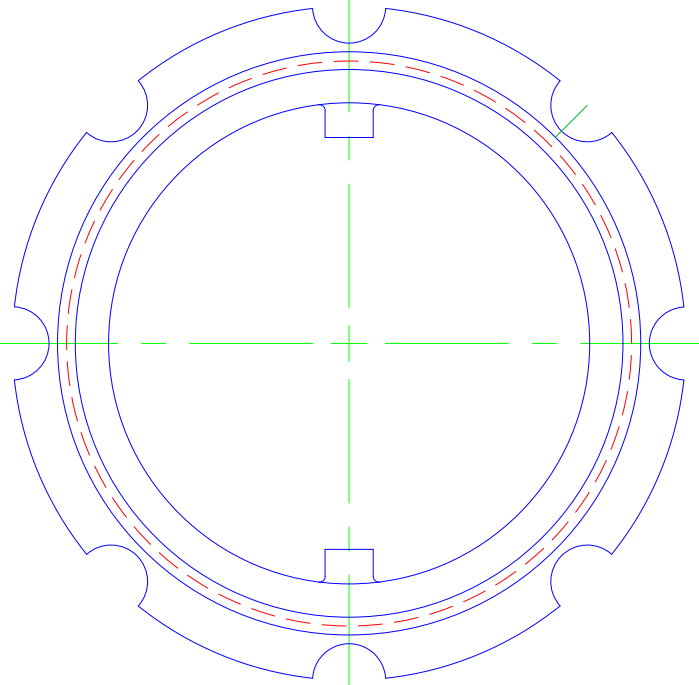
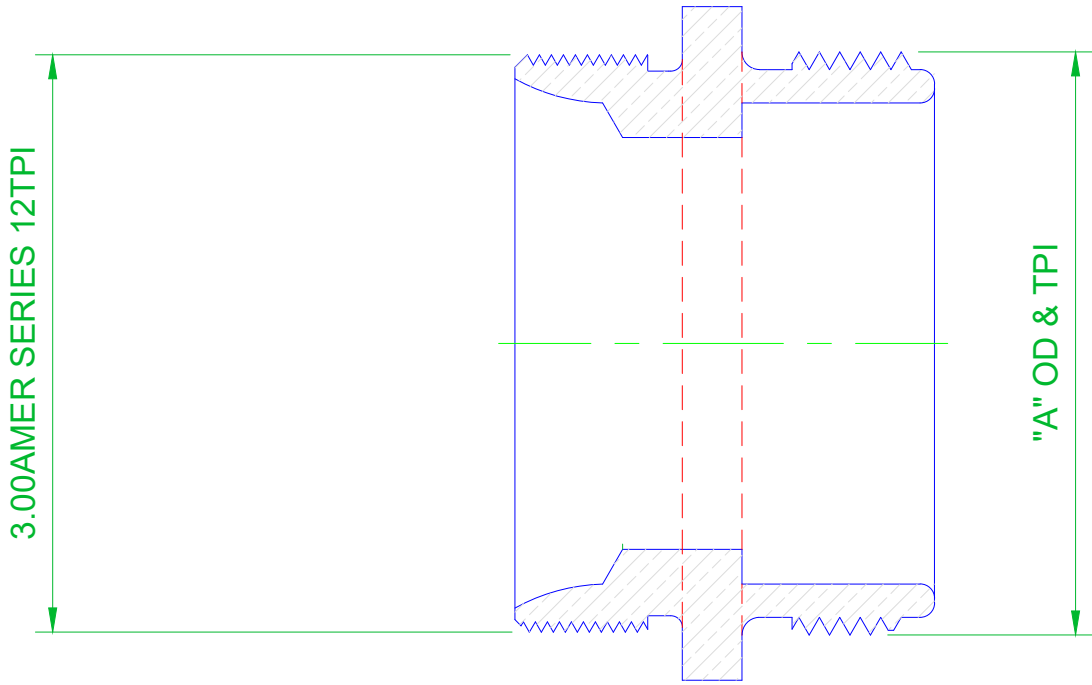

STAMPING LETTER	'A' O.D. & T.P.I.
A	2 31/32-8
B - AMA	2 31/32-8
C	2.987-8
D - BC STD	3"-8
E	3 1/32-8
F	3 1/16-8
G	3 3/32-8
X	2 1/2 BPT-11
Y	2 1/2 NPS,
Z	2 1/2 NPT
AA - QC STD	3 1/32-7
BB	3 1/32-7
CC	3 1/16-7
JJ	3 1/16-7 1/2
LL	3 3/16-6
NN - WC US	3 1/4-6
SS - CSA STD	3 1/8-5
TT	3 7/32-5
W	3 1/4-5
YY	3 1/4-5
ZZ	3 1/4-5 1/2
SB	3.20-5

MATERIAL  
 BRONZE ASTM  
 B-584 ALLOY C84400  
 B-584 ALLOY C87850

REF. NOS.

CHECKED	<b>M67B HOSE NOZZLE</b>
EXAMINED	
NOTED	
APPROVED	<b>CLOW CANADA</b>
	SCALE <b>FULL SIZE</b> DATE <b>JUNE 25/2003</b>