

PROJECT	750 - 1200 R/W VALVE MECH. JOINT ENDS BEVEL GEAR GENERAL DIMENSIONS
OWNER	
CONTRACTOR	
DISTRIBUTOR	
CONSULTANT	F6100BG
<b>CLOW CANADA</b>	
FUSION EPOXY - NSF 61 AND AWWA C550	

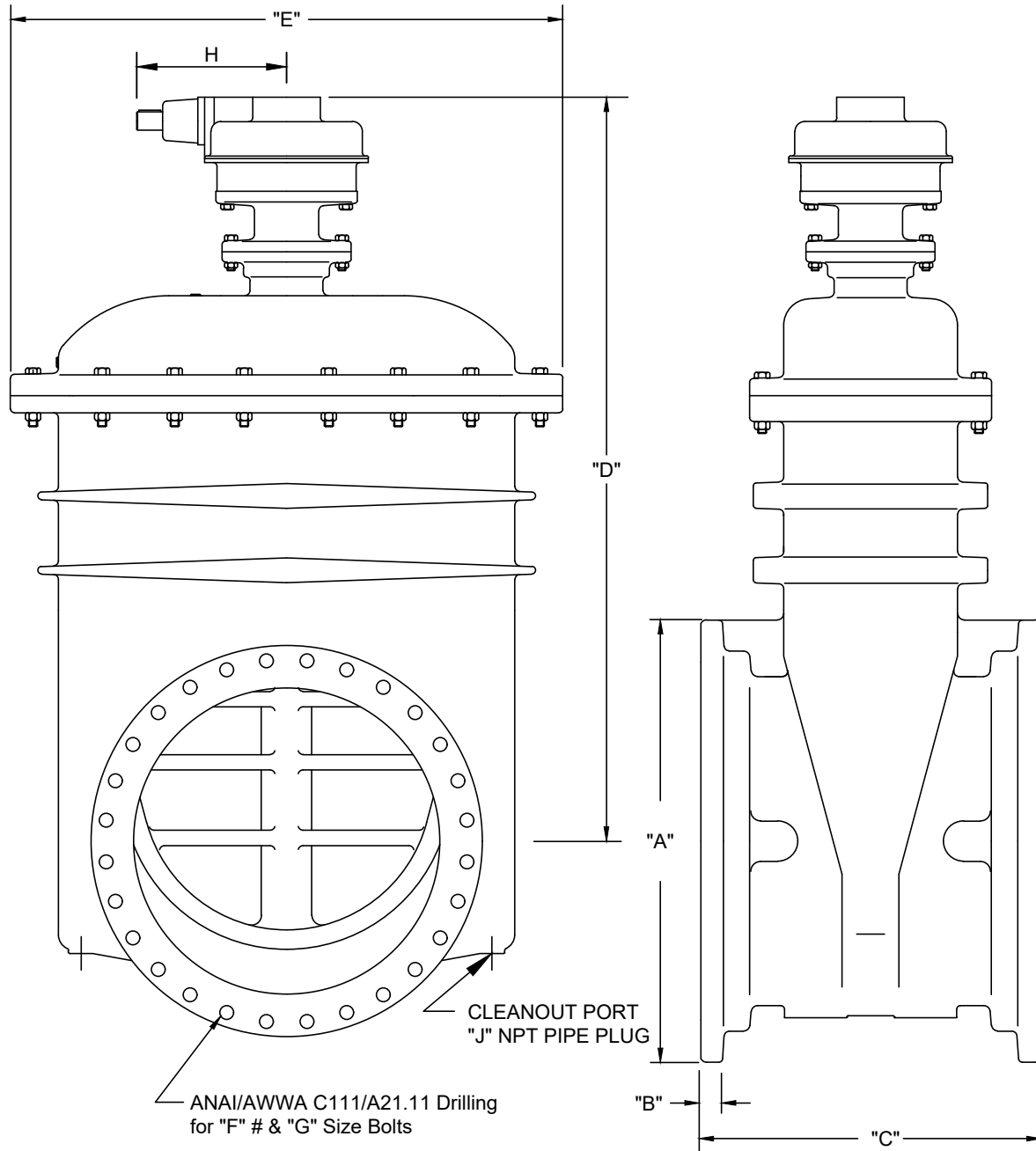

**METRIC DIMENSIONS**

Valve Size	A	B	C	D	E	F	G	H	J
750 mm	1003	45	1232	1816	1390	20	1"	378	51
900 mm	1181	51	984	2059	1495	24	1"	378	32
1050 mm	1372	51	990	2372	1981	28	1 1/4	432	38
1200 mm	1543	51	1067	2575	1981	32	1-1/4	432	38