



KENNEDY VALVE

# 2”-12” Resilient Wedge Gate Valve Model KS FW C509 General Dimensions



AWWA

Note: 2” OS&Y Flanged and Threaded versions are UL Listed

All OS&Y Gates incorporate a pre-grooved stem for supervisory switch

END CONNECTIONS	STEM TYPE	SIZE RANGE	FIGURE NO.	w/ POST PLATE	PAGE NO.
Flanged Ends	Non-Rising	2”-12”	8561ASS	8701ASS (3”-12”)	2, 3, 6
Mechanical Joint	Non-Rising	2”-12”*	8571SS	8701SS (3”-12”)	2, 3, 8
Flange x Mechanical Joint	Non-Rising	3”-12”	8572SS	8702SS (3”-12”)	2, 3, 9
Push-on for PVC (SDR)	Non-Rising	2”-8”	8597SS	8597PSS (3”-8”)	2, 3, 12
Flanged Ends	OS&Y	2”-12”	8068A	N/A	4, 5, 7
Mechanical Joint x Tap Ends	Non-Rising	4”-12”	8950SS	8950PSS	2, 3, 15
Push-on for D.I. & C900 PVC	Non-Rising	4”-12”	8901SS	8901PSS	2, 3, 10
M.J. Cutting-in	Non-Rising	4”-12”	8576SS	8576PSS	2, 3, 13
Push-on for D.I. x Fig.	Non-Rising	4”-12”	8902SS	8902PSS	2, 3, 11
Threaded	Non-Rising	2”-3”	8057SS	8057PSS (3” only)	2, 3, 14
Threaded	OS&Y	2”-3”	8067SS	N/A	4, 5, 16

\*excludes 2½”

\*\*SDR - Standard Dimension Ratio

SIZE RANGE	WATER WORKING PRESSURE PSI	SEAT TEST PSI	HYDROSTATIC SHELL TEST PSI
AWWA 2”-12”	250 Water Work	300	500
ULFM 2”-12”	200 Fire Protection	300	500

Available in either non-rising stem or outside screw & yoke.

### ACCESSORIES

- |                       |                               |
|-----------------------|-------------------------------|
| Indicator Posts       | Floorstands (Non-Rising Stem) |
| “T” Handles”          | Handwheels                    |
| Stem Guides           | Extension Stems               |
| 2” Sq. Operating Nuts | Chain Wheels                  |
| Floor Boxes           |                               |



**KENNEDY VALVE**

## 2"-12" Resilient Seated Gate Valve KS FW Non-Rising Material List



AWWA

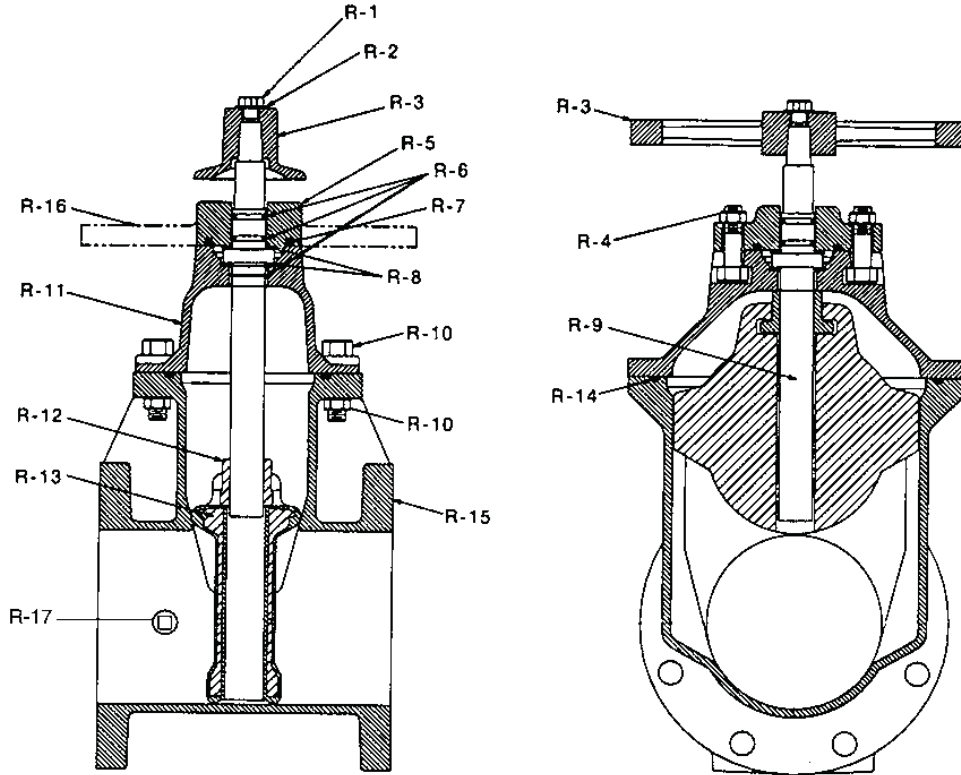

PIPE PLUG STANDARD ON FLANGE & GROOVE VALVES @ POSITION "A"

DET.	NAME OF PART	MATERIAL	ASTM SPEC.
R-1	Hex Head Bolt	Stainless Steel	ASTM F593C
R-2	Flat Washer	Zinc Plated Steel	ASTM A307
R-3	Operating Nut	Cast Iron	ASTM A126 Class B
	Handwheel	Cast Iron	ASTM A126 Class B
R-4	Hex Bolt & Nut	Stainless Steel	ASTM F593C/F594
R-5	Stuffing Box	2" thru 8"	Cast Iron ASTM A126 Class B
		10" and 12"	Ductile Iron ASTM A536 Grade 70-50-5
R-6	O-Ring (Stem)	EPDM	-----
R-7	O-Ring (Stuffing Box)	EPDM	-----
R-8	Thrust Washer	Delrin	-----
R-9	Stem	Bronze	ASTM B584 C86700
R-10	Hex Head Cover Bolts & Nuts	Stainless Steel	ASTM F593C/F594
R-11	Cover	Cast Iron	ASTM A126 Class B
R-12	Stem Nut	Bronze (NDZ)	ASTM B763 C99500
R-13	Wedge (EPDM Encapsulated)	Ductile Iron	ASTM A536 Grade 70-50-5
R-14	O-Ring (Cover)	EPDM	-----
R-15	Body (All Types)	Cast Iron	ASTM A126 Class B
R-16	Plate	Cast Iron	ASTM A126 Class B
R-17	Pipe Plug: 1/2"; 2 1/2"-4"--3/4"; 6'-12"	Galvanized Steel	-----



KENNEDY VALVE

## 2"-12" Resilient Seated Gate Valve KS FW Non-Rising Assembly Explosion



AWWA

DET.	QTY.	DESCRIPTION	MATERIALS
R-1	1	Hold Down Hex Bolt	Stainless Steel
R-2	1	Hold Down Bolt Washer	Zinc Plated Steel
R-3	1	Sq. Operating Nut OR Handwheel (Not Shown)	Cast Iron
R-4	2	Bolt & Nut (Stuffing Box)	Stainless Steel
R-5	1	Stuffing Box (10" & 12" D.I.)	Cast Iron
R-6	3	O-Ring (Stem) 1 Below Collar	EPDM
R-7	1	O-Ring (Stuffing Box)	EPDM
R-8	1	Thrust Washer (Sizes 2"-2 1/2")	
	2	Thrust Washer (Sizes 3" thru 12")	Delrin
R-9	1	Stem	Bronze
R-10	4	Cover Bolts & Nuts (Sizes 2" thru 6")	Stainless Steel
	8	Cover Bolts & Nuts (Sizes 8" thru 12")	Stainless Steel
R-11	1	Cover	Cast Iron
R-12	1	Stem Nut	Bronze
R-13	1	Wedge Disc	D.I. - EPDM Coated
R-14	1	O-Ring (Cover)	EPDM
R-15	1	Body	Cast Iron

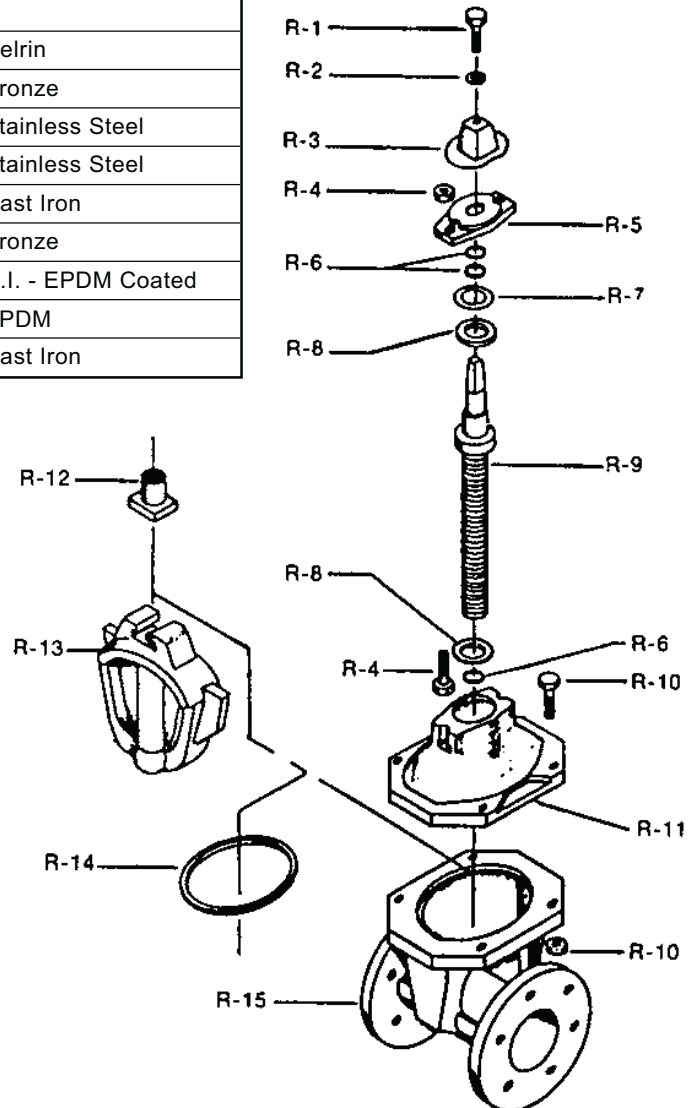



**KENNEDY VALVE**

## 2"-12" Resilient Seated Gate Valve KS FW OS&Y Materials List



AWWA

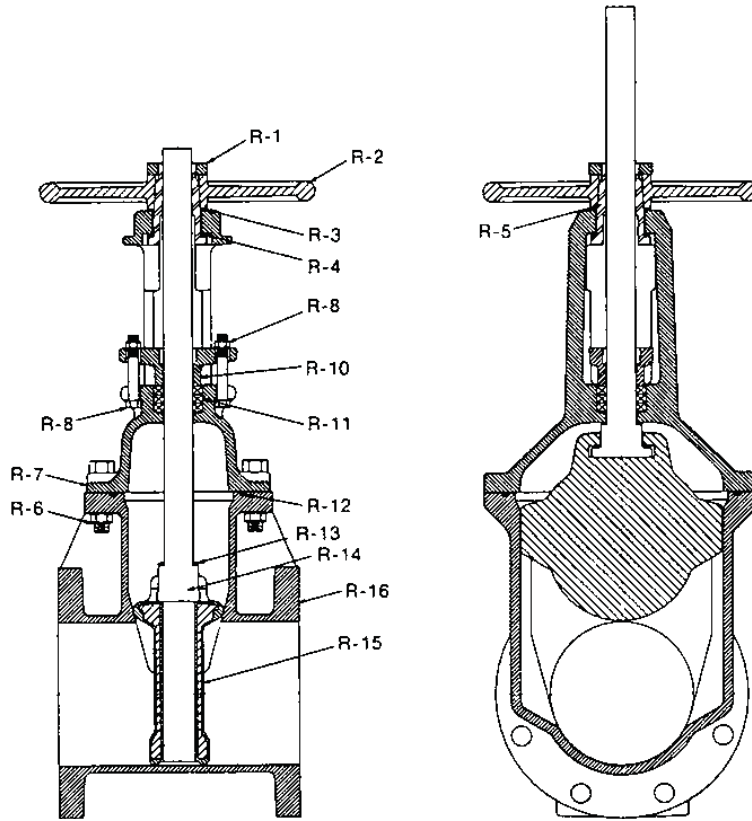

PIPE PLUG STANDARD ON FLANGE & GROOVE VALVES @ POSITION "A"

DET.	NAME OF PART	MATERIAL	ASTM SPEC.
R-1	Handwheel Nut	Bronze (AWWA Grade A)	ASTM B584 C84400
R-2	Handwheel	Cast Iron	ASTM A126 Class B
R-3	Upper Thrust Washer	Brass	ASTM B36 C26000
R-4	Lower Thrust Washer	Nylatron	-----
R-5	Yoke Nut	Bronze	ASTM B584 C86700
R-6	Hex. Head Cover Bolts & Nuts	Zinc Plated Steel	Grade 2 SAE J429
R-7	Cover	Cast Iron	ASTM A126 Class B
R-8	Packing Bolts	Zinc Plated Steel	Grade 2 SAE J429
R-8	Packing Bolt Nuts	Brass	ASTM F467
R-10	Packing Gland	Ductile Iron	ASTM A536 Grade 70-50-5
R-11	Packing	Sq. Braided Non-Asbestos	-----
R-12	O-Ring (Cover)	EPDM	-----
R-13	O-Ring (Stem)	EPDM	-----
R-14	Stem -- Pre-grooved	Stainless Steel	ASTM A276 Type 304
R-15	Wedge (EPDM Encapsulated)	Ductile Iron	ASTM A536 Grade 70-50-5
R-16	Body (All Types)	Cast Iron	ASTM 126 Class B
R-17	Pipe Plug: 1/2"; 2 1/2"-4"--3/4"; 6'-12"	Galvanized Steel	-----



KENNEDY VALVE

# 2"-12" Resilient Seated Gate Valve KS FW OS&Y Assembly Explosion



AWWA

DET.	QTY.	DESCRIPTION	MATERIALS
R-1	1	Handwheel Hold Down Nut	Bronze
R-2	1	Handwheel	Cast Iron
R-3	1	Upper Thrust Washer (Sizes 3" thru 12")	Bronze
R-4	1	Lower Thrust Washer	Bronze
R-5	1	Yoke Nut	Bronze
R-6	4	Cover Bolts & Nuts (Sizes 2-1/2" thru 6")	Zinc Plated Steel
R-6	8	Cover Bolts & Nuts (Sizes 8" thru 12")	Zinc Plated Steel
R-7	1	Cover	Cast Iron
R-8	2	Packing Bolts	Zinc Plated Steel
R-8	2	Packing Bolt Nuts	Brass
R-10	1	Packing Gland	Ductile Iron
R-11		Packing	Sq. Braided Polymer
R-12	1	O-Ring (Cover)	EPDM
R-13	1	O-Ring (Stem)	EPDM
R-14	1	Stem -- Pre-grooved	Stainless
R-15	1	Wedge Disc	D.I. - EPDM Coated
R-16	1	Body	Cast Iron
R-17	1	Pipe Plug	Galvanized Steel

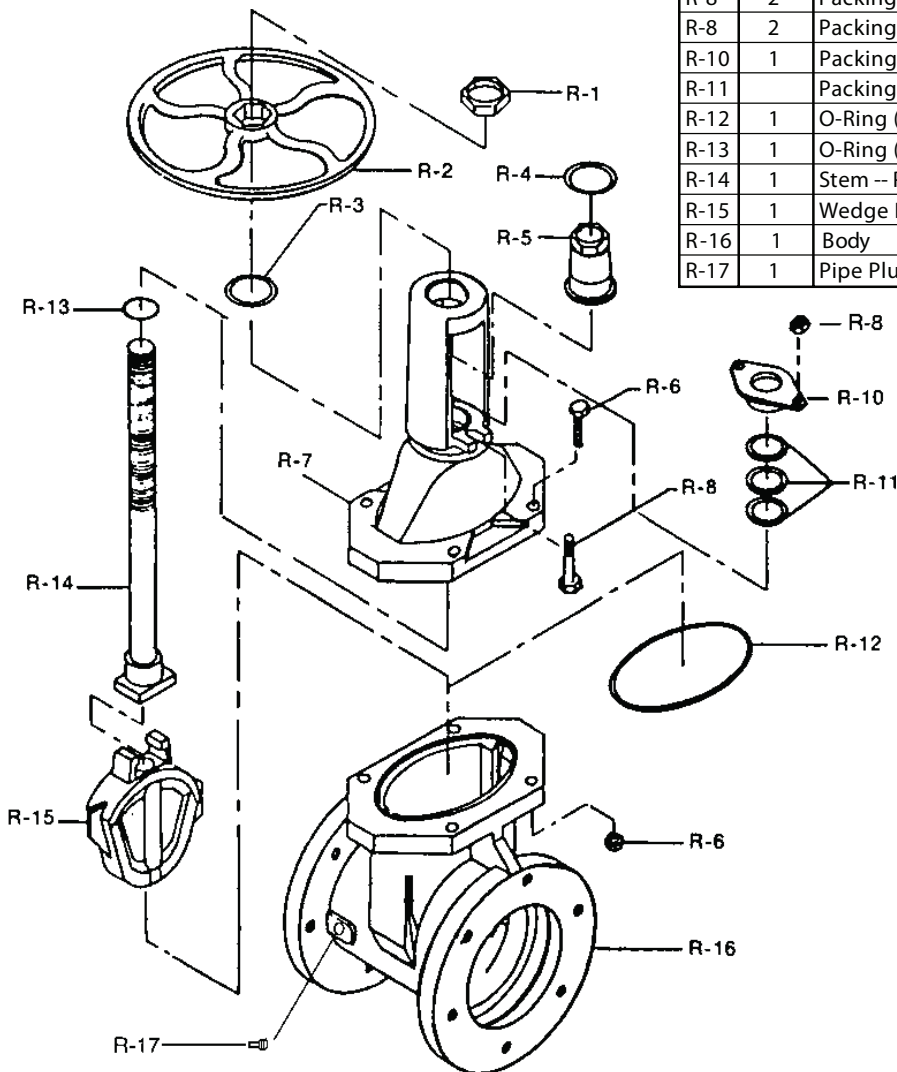



KENNEDY VALVE

## 2"-12" Resilient Seated Gate Valve KS FW Non-Rising Flange Ends General Dimensions



AWWA

Fig. 8561ASS (with handwheel)

Fig. 8561ANSS (with nut)

Fig. 8701ASS 3"-12" (with post plate)

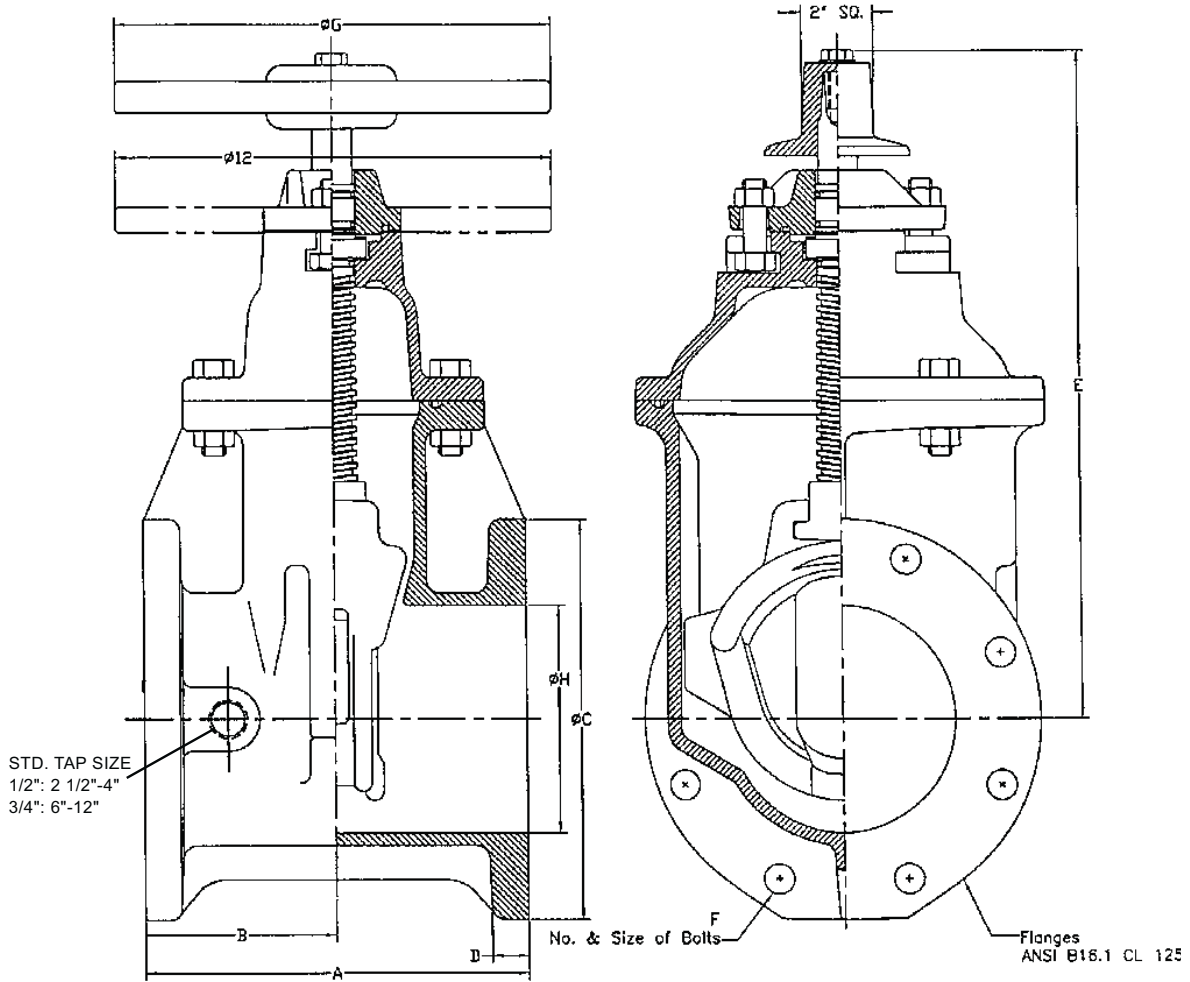

ALL FLANGE VALVES TAPPED & PLUGGED @ POSITION "A"

VALVE SIZE	* A	B	C	D	E	F	G	H	WEIGHT*
2	7	3 1/2	6	11/16	10 7/8	4 5/8	7 1/4	2	41
2 1/2	7 1/2	3 3/4	7	11/16	11 3/8	4 5/8	7 1/4	2 1/2	49
3	8	4	7 1/2	3/4	12 3/8	4 5/8	10	3	62
4	9	4 1/2	9	15/16	14 3/4	8 5/8	10	4 1/4	99
6	10 1/2	5 1/4	11	1	19	8 3/4	12	6 1/4	142
8	11 1/2	5 3/4	13 1/2	1 1/8	22 1/2	8 3/4	14	8 1/4	239
10	13	6 1/2	16	1 3/16	26 1/2	12 7/8	18	10 1/4	408
12	14	7	19	1 1/4	30	12 7/8	18	12 1/4	554

NOTE: ADD 16 LBS. FOR INDICATOR POST PLATE (3"-12" ONLY)



KENNEDY VALVE

2"-12" Resilient Seated Gate Valve  
 KS FW OS&Y  
 Flange Ends  
 General Dimensions



Fig. 8068A

AWWA

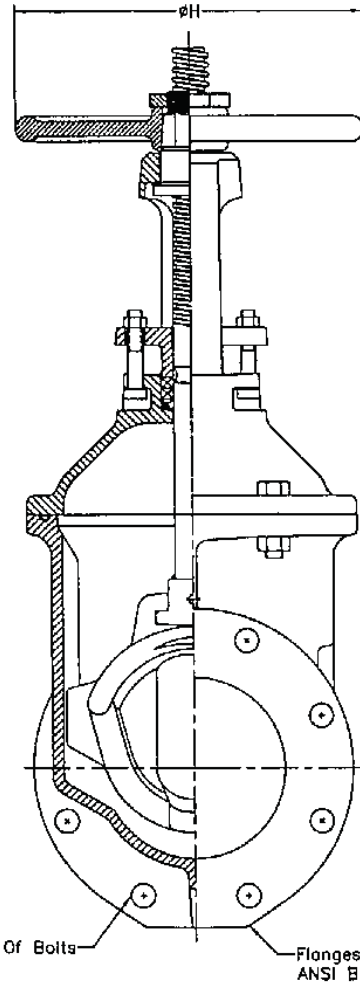
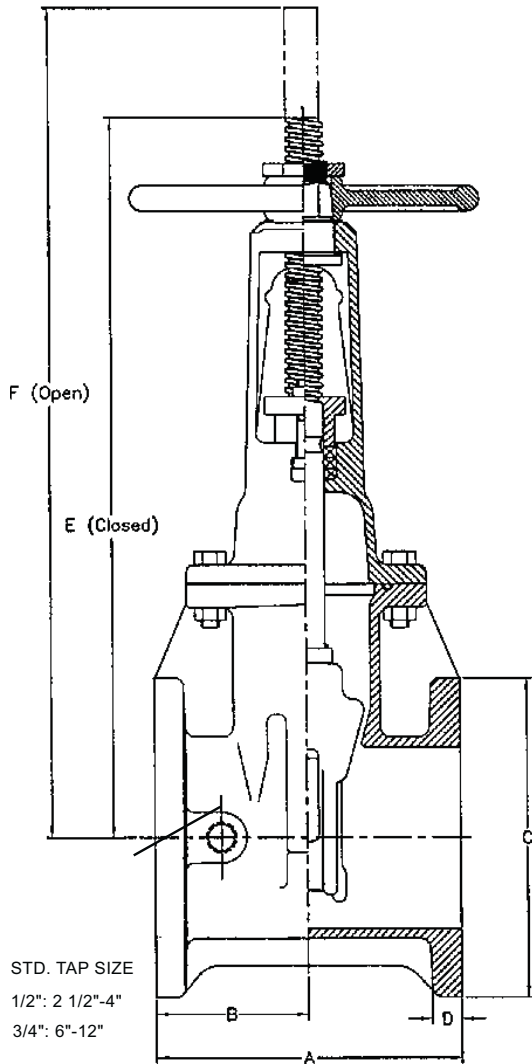

VALVE SIZE	* A	B	C	D	E	F	G	H	WEIGHT
2	7	3 1/2	6	5/8	12	10	4 5/8	7 1/4	N/A
2 1/2	7 1/2	3 3/4	7	11/16	13 7/8	16 3/8	4 5/8	7 1/4	51
3	8	4	7 1/2	3/4	15 5/8	18 7/8	4 5/8	10	64
4	9	4 1/2	9	15/16	18 1/4	22 3/4	8 5/8	10	105
6	10 1/2	5 1/4	11	1	23 3/4	30 1/8	8 3/4	12	152
8	11 1/2	5 3/4	13 1/2	1 1/8	29 1/4	37 3/4	8 3/4	14	253
10	13	6 1/2	16	1 3/16	35 3/8	45 3/4	12 7/8	18	427
12	14	7	19	1 1/4	40 5/8	53 1/8	12 7/8	18	581



KENNEDY VALVE

**2"-12" Resilient Seated Gate Valve**  
**KS FW**  
**Mechanical Joint Ends**  
**General Dimensions**



Fig. 8571SS

Fig. 8071SS 3"-12" (with post plate)

AWWA

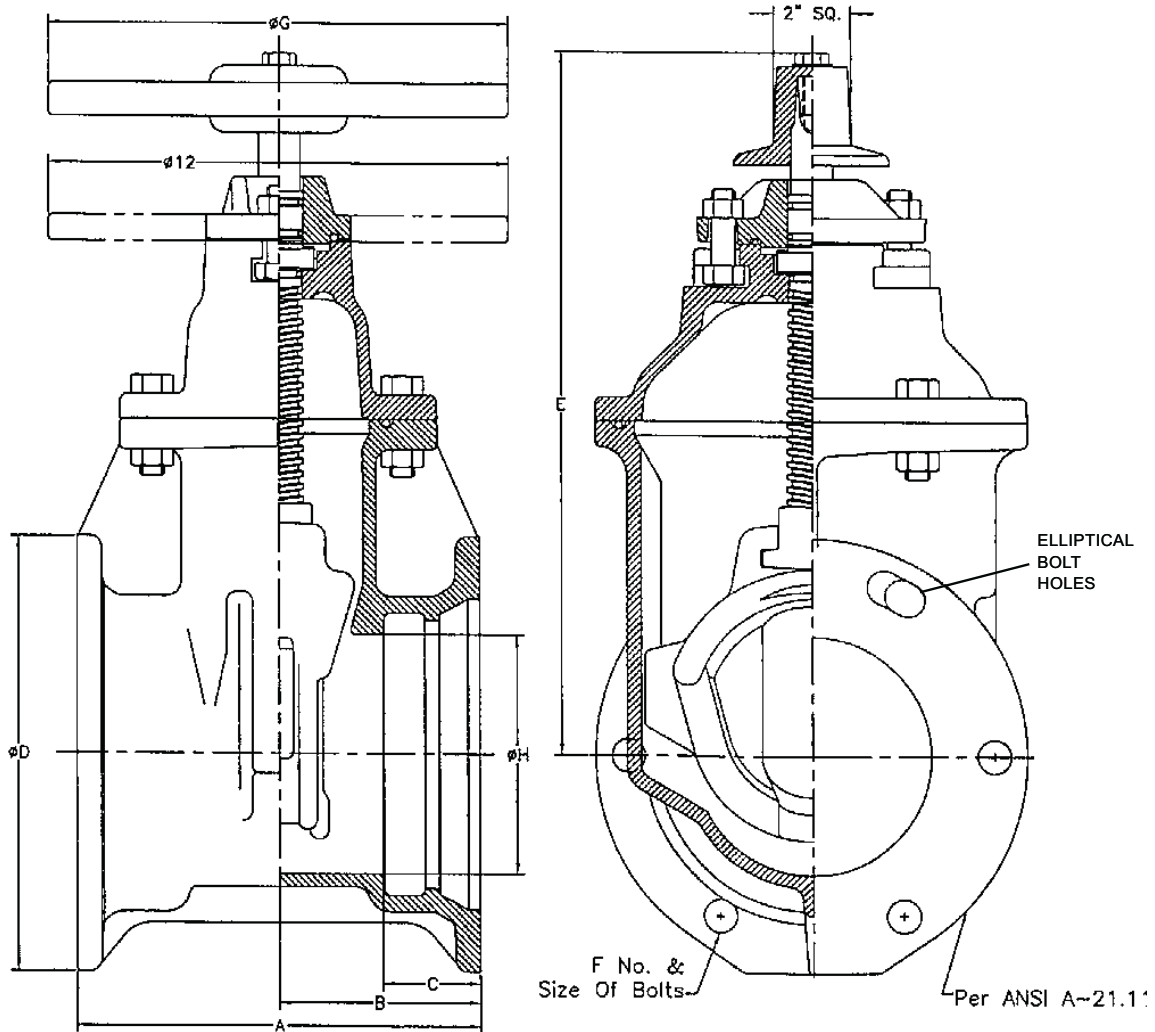

ELLIPTICAL BOLT HOLE DESIGN ELIMINATES THE NEED FOR ANTI-ROTATIONAL BOLTS

VALVE SIZE	A	B	C	D	E	F	G	H	WEIGHT*
2	8 1/4	4 1/8	2 1/2	4 1/2	10 7/8	4 5/8	7 1/4	2	36
2 1/2	—	—	—	—	—	—	—	—	—
3	8 1/2	4 1/4	2 1/2	7 3/4	12 3/8	4 5/8	10	3	59
4	9 1/2	4 3/4	2 1/2	9 1/8	14 3/4	4 3/4	10	4 1/4	86
6	10 1/2	5 1/2	2 1/2	11 3/8	19	6 3/4	12	6 1/4	134
8	13 1/8	6 9/16	2 1/2	13 3/4	22 1/2	6 3/4	14	8 1/4	206
10	15 1/2	7 3/4	2 1/2	15 3/4	26 1/2	8 3/4	18	10 1/4	351
12	16	8	2 5/8	18	30	8 3/4	18	12 1/4	473

\*ADD 16 LBS. FOR INDICATOR POST PLATE (3"-12" only)





KENNEDY VALVE

# 3"-12" Resilient Seated Gate Valve KS FW Non-Rising Mechanical Joint Ends General Dimensions



Fig. 8572SS  
Fig. 8702SS (with post plate)

AWWA

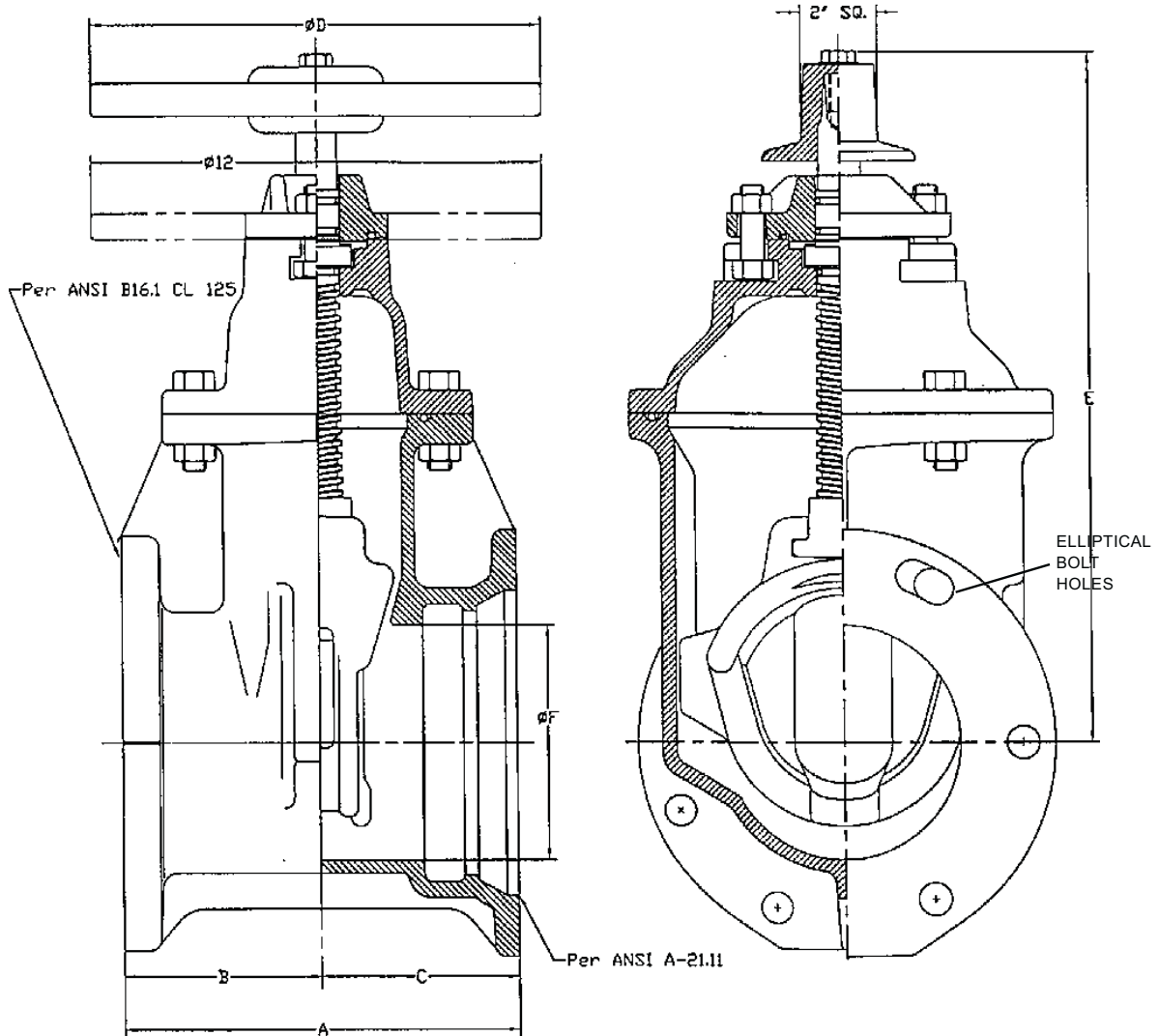

ELLIPTICAL BOLT HOLE DESIGN ELIMINATES THE NEED FOR ANTI-ROTATIONAL BOLTS

VALVE SIZE	A	B	C	D	E	F	WEIGHT*
3	8 1/4	4	4 1/4	10	12 3/8	3	60
4	9 1/4	4 1/2	4 3/4	10	14 3/4	4 1/4	79
6	10 1/2	5 1/4	5 1/4	12	19	6 1/4	134
8	12 5/16	5 3/4	6 9/16	14	22 1/2	8 1/4	213
10	14 1/4	6 1/2	7 3/4	18	26 1/2	10 1/4	365
12	15	7	8	18	30	12 1/4	497

\*ADD 16 LBS. FOR INDICATOR POST PLATE



KENNEDY VALVE

# 4"-12" Resilient Seated Gate Valve KS FW Non-Rising Tyton Ends General Dimensions



Fig. 8901SS  
Fig. 8901PSS (with post plate)

AWWA

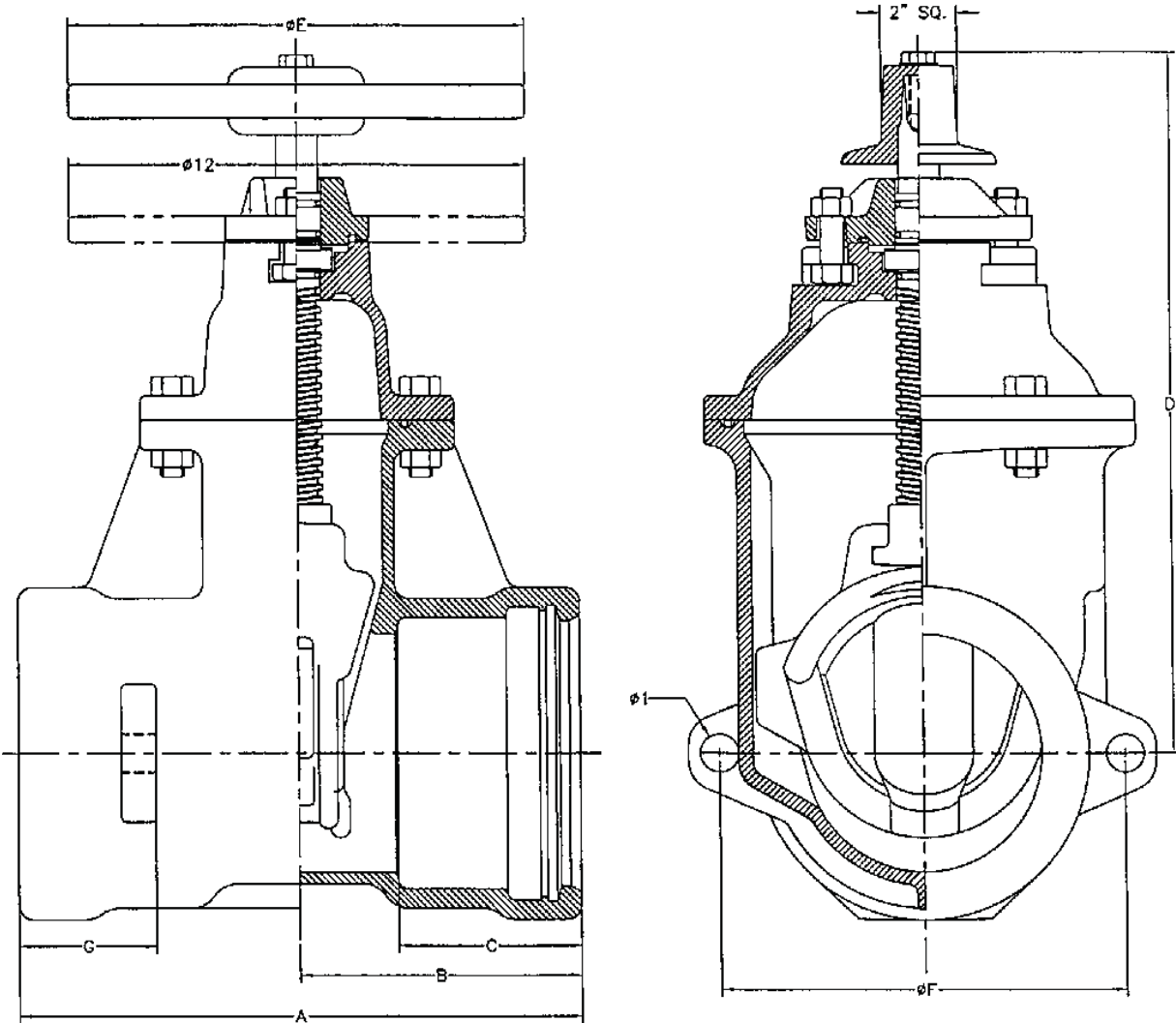

VALVE SIZE	A	B	C	D	E	F	G	WEIGHT*
4	13 1/4	6 5/8	4.34	14 3/4	10	8 3/16	3 3/4	82
6	14 3/4	7 3/8	4.75	19	12	10 7/8	3 3/4	139
8	17 1/8	8 9/16	5.70	22 1/2	14	12 7/8	4 1/2	216
10	19 3/8	9 11/16	6.19	26 1/2	18	15 15/16	5 1/8	359
12	20 7/8	10 7/16	6.19	30	18	17 7/16	5 3/8	501

\*ADD 16 LBS. FOR INDICATOR POST PLATE



KENNEDY VALVE

# 4"-12" Resilient Seated Gate Valve KS FW Non-Rising Flange x Tyton Ends General Dimensions



Fig. 8902SS  
Fig. 8902PSS (with post plate)

AWWA

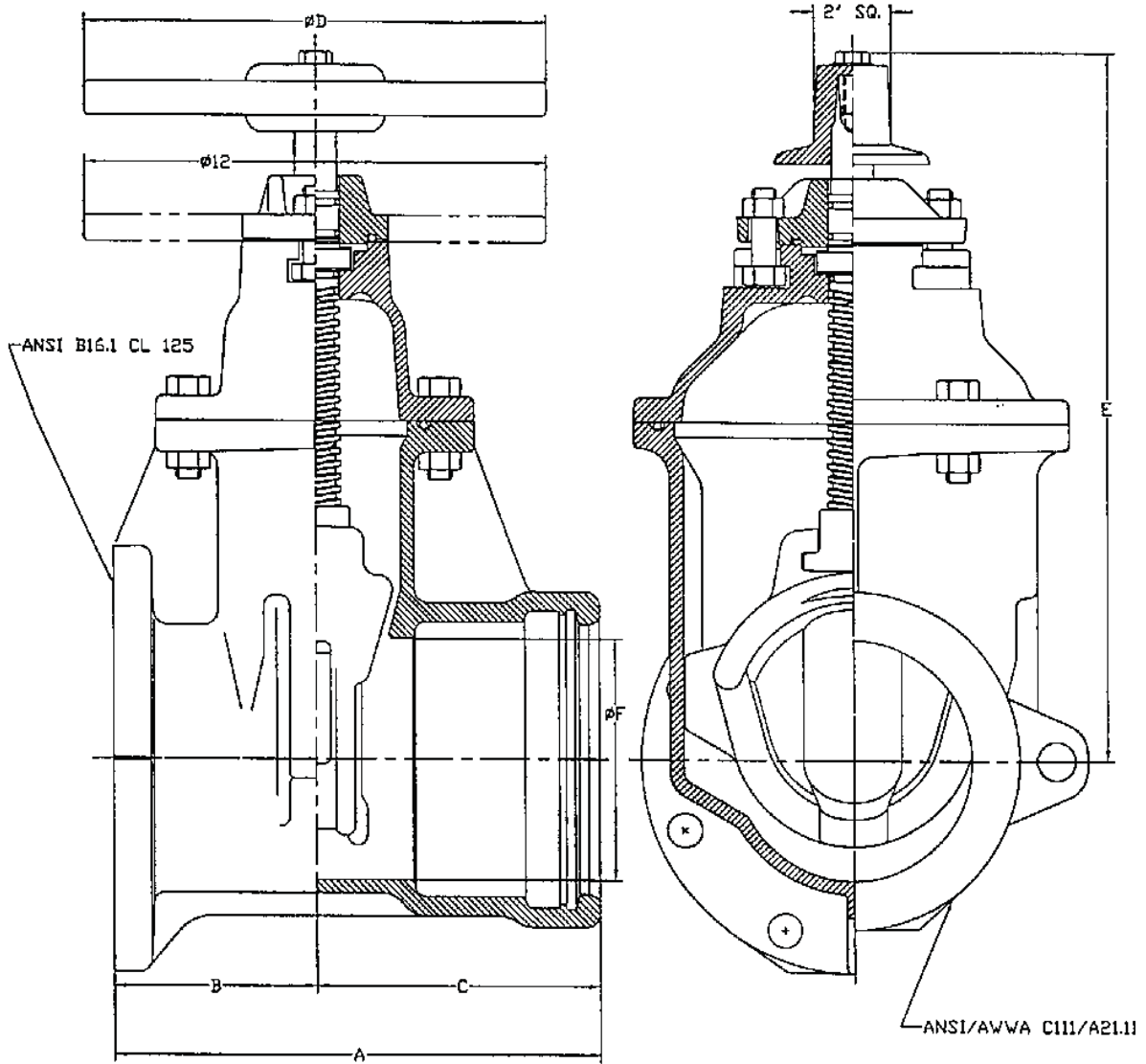

VALVE SIZE	A	B	C	D	E	F	WEIGHT*
4	11 1/8	4 1/2	6 5/8	10	14 3/4	4 1/4	85
6	12 5/8	5 1/4	7 3/8	12	19	6 1/4	139
8	14 5/16	5 3/4	8 9/16	14	22 1/2	8 1/4	219
10	16 3/16	6 1/2	9 11/16	18	26 1/2	10 1/4	372
12	17 7/16	7	10 7/16	18	30	12 1/4	515

\*ADD 16 LBS. FOR INDICATOR POST PLATE



KENNEDY VALVE

# 2"-12" Resilient Seated Gate Valve KS FW Non-Rising PVC Ends General Dimensions



Fig. 8597SS  
Fig. 8597PSS 3"-8" (with post plate)

AWWA

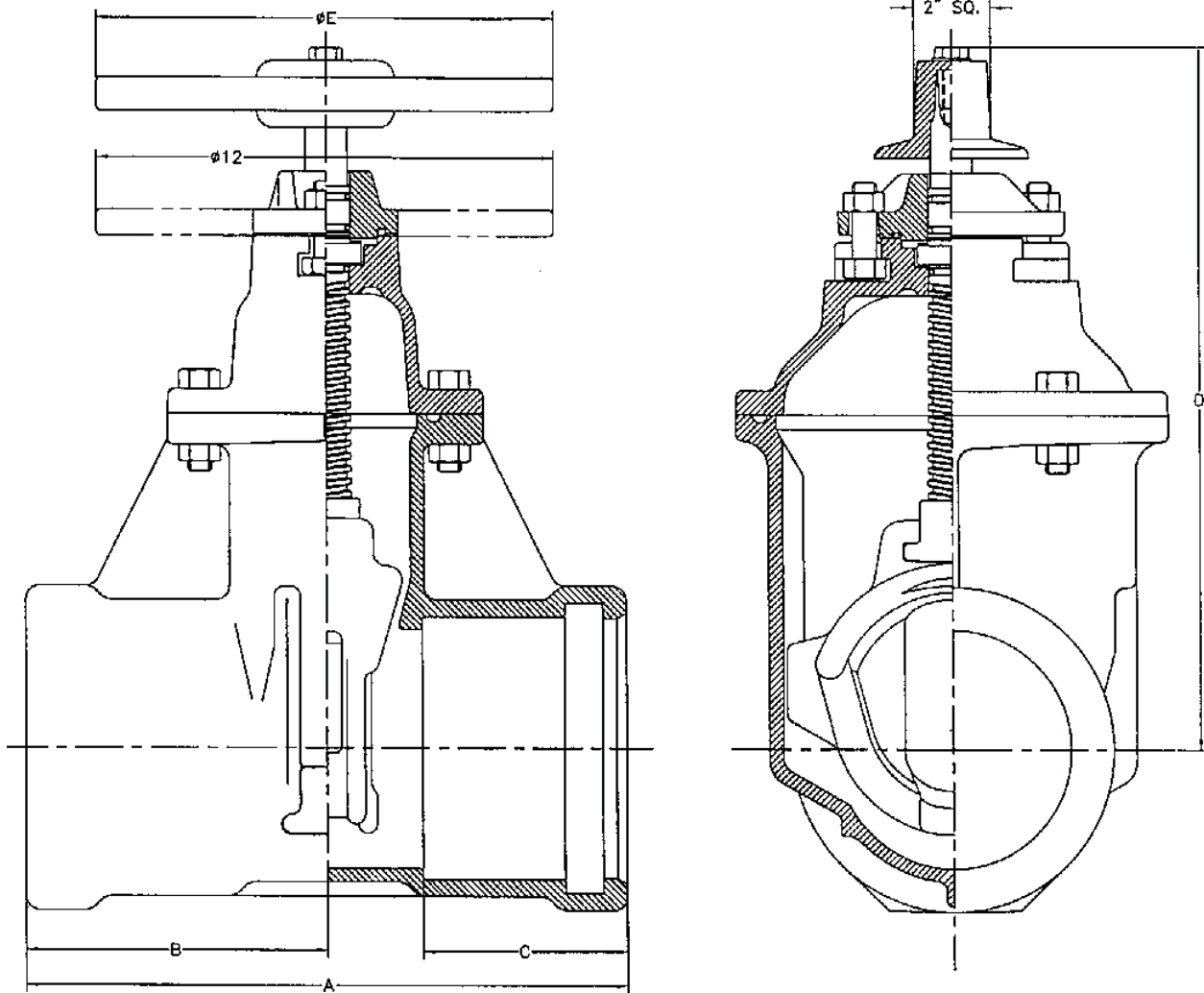

VALVE SIZE	A	B	C	D	E	WEIGHT*
2	10	5	3 1/2	10 7/8	7 1/4	35
2 1/2	10 3/4	5 3/8	3 3/4	11 3/8	7 1/4	44
3	11 5/8	5 13/16	4 1/6	12 3/8	10	53
4	13 1/2	6 3/4	4 1/2	14 3/4	10	84
6	15 3/4	7 7/8	5 3/8	19	12	137
8	16 1/4	8 1/8	5 3/8	22 1/2	14	223

\*ADD 16 LBS. FOR INDICATOR POST PLATE (3" - 8" only)



KENNEDY VALVE

**2"-12" Resilient Seated Gate Valve  
KS FW Non-Rising  
Mechanical Cut Joint Ends  
General Dimensions**



Fig. 8576SS  
Fig. 8576PSS (with post plate)

AWWA

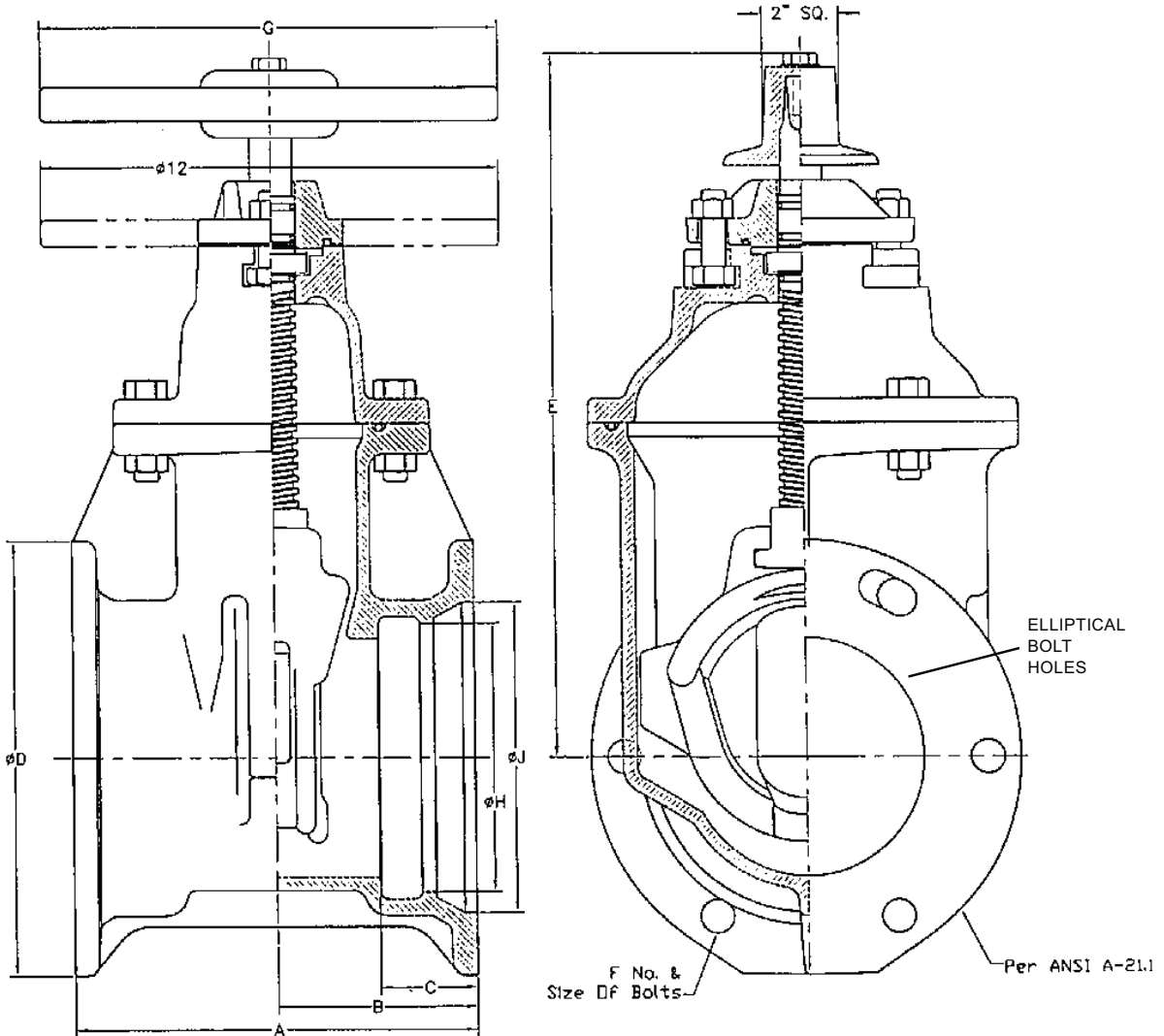

ELLIPTICAL BOLT HOLE DESIGN ELIMINATES THE NEED FOR ANTI-ROTATIONAL BOLTS

VALVE SIZE	A	B	C	D	E	F	G	H	J	WEIGHT*
4	9 1/2	4 3/4	2 1/2	9 1/8	14 3/4	4 3/4	10	5 .10	6.20	86
6	10 1/2	5 1/4	2 1/2	11 3/8	19	6 3/4	12	7 .20	8.30	134
8	13 1/8	6 9/16	2 1/2	13 3/4	22 1/2	6 3/4	14	9.40	10.50	206
10	15 1/2	7 3/4	2 1/2	15 3/4	26 1/2	8 3/4	18	11.50	12.62	351
12	16	8	2 5/8	18	30	8 3/4	18	13.60	14.72	473

\*ADD 16 LBS. FOR INDICATOR POST PLATE



KENNEDY VALVE

# 2"-3" Resilient Seated Gate Valve KS FW Non-Rising Threaded Ends General Dimensions



Fig. 8057SS (2" nut)  
Fig. 8057WSS (with handwheel)

AWWA

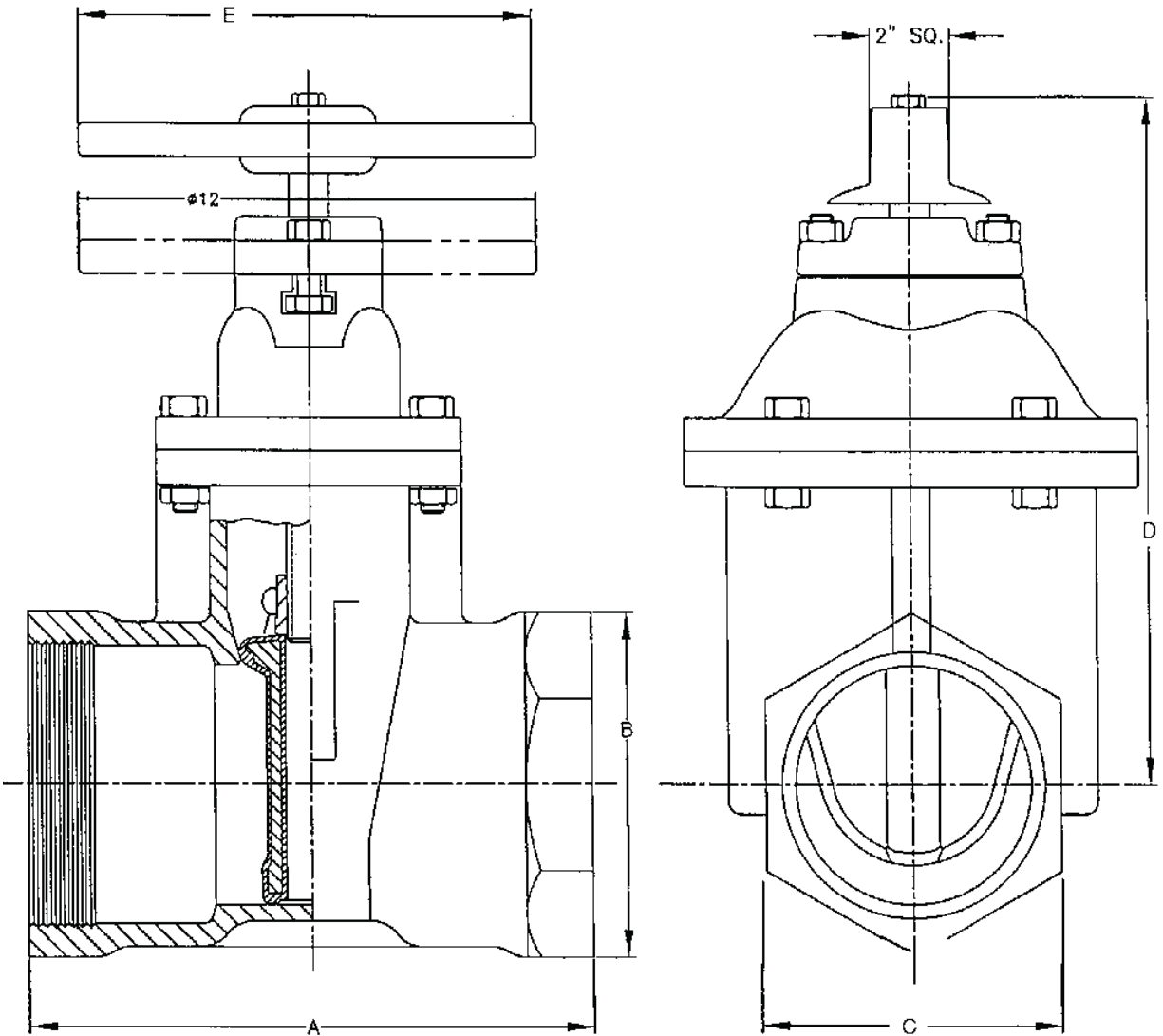

VALVE SIZE	A	B	C	D	E	WEIGHT*
2	5 1/4	4 1/8	3 9/16	10 7/8	7 1/4	20
2 1/2	7	5 3/16	4 1/2	11 3/8	7 1/4	40
3	7 1/8	5 5/8	4 7/8	12 3/8	10	47

\*ADD 16 LBS. FOR INDICATOR POST PLATE (3" ONLY)



KENNEDY VALVE

**3"-12" Resilient Seated Gate Valve**  
**KS FW Non-Rising**  
**Tap x Mechanical Joint Ends**  
**General Dimensions**



Fig. 8950SS  
 Fig. 8950PSS (with post plate)

AWWA

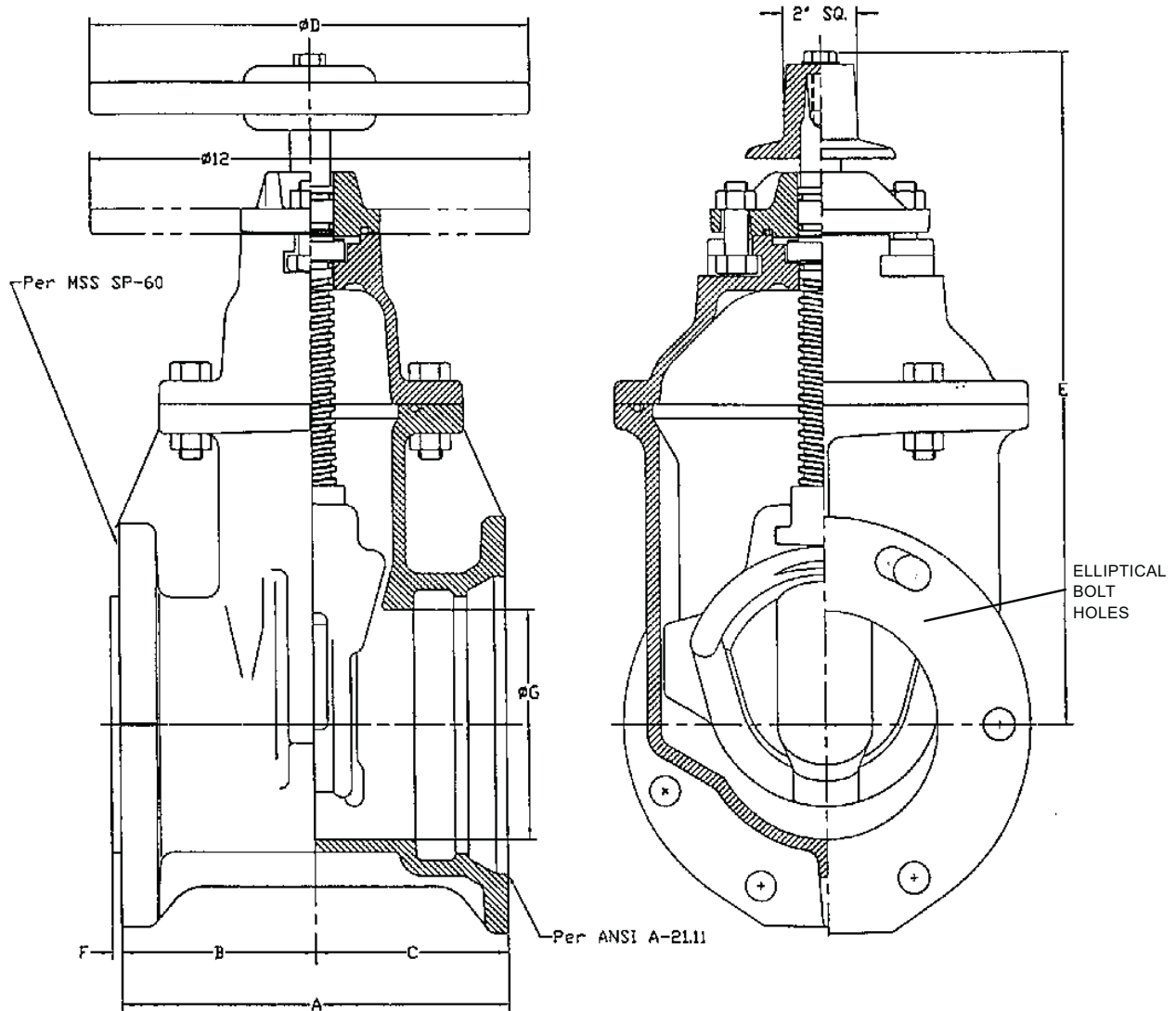

ELLIPTICAL BOLT HOLE DESIGN ELIMINATES THE NEED FOR ANTI-ROTATIONAL BOLTS

VALVE SIZE	A	B	C	D	E	F	G	WEIGHT*
4	9 1/4	4 1/2	4 3/4	10	14 3/4	3/16	4 1/4	92
6	10 1/2	5 1/4	5 1/4	12	19	1/4	6 1/4	144
8	13 1/4	5 3/4	7 1/2	14	22 1/2	1/4	8 1/4	224
10	14 1/4	6 1/2	7 3/4	18	26 1/2	1/4	10 1/4	392
12	15	7	8	18	30	1/4	12 1/4	527

\*ADD 16 LBS. FOR INDICATOR POST PLATE



KENNEDY VALVE

# 2"-3" Resilient Seated Gate Valve KS FW OS&Y Threaded Ends General Dimensions



Fig. 8067

AWWA

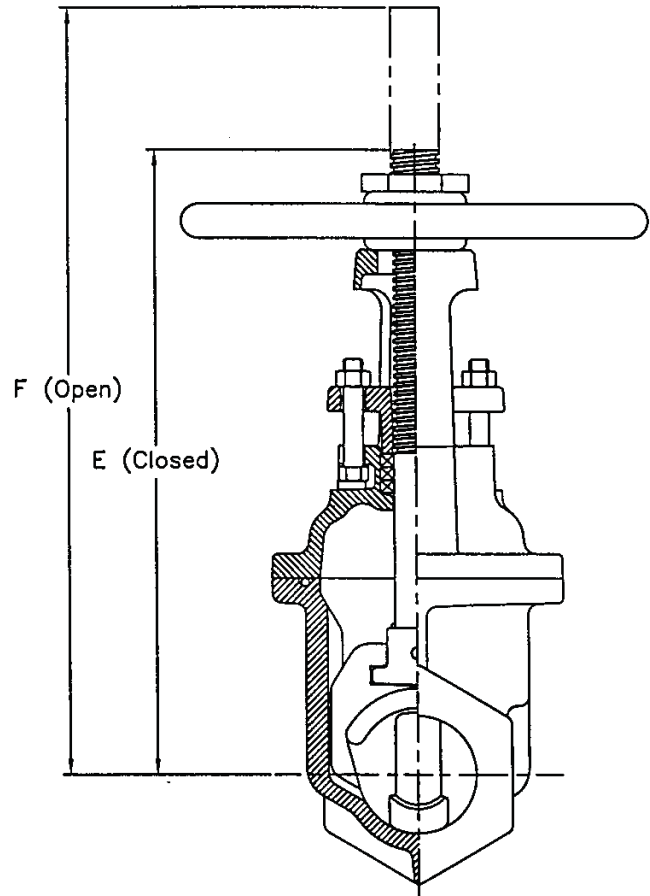
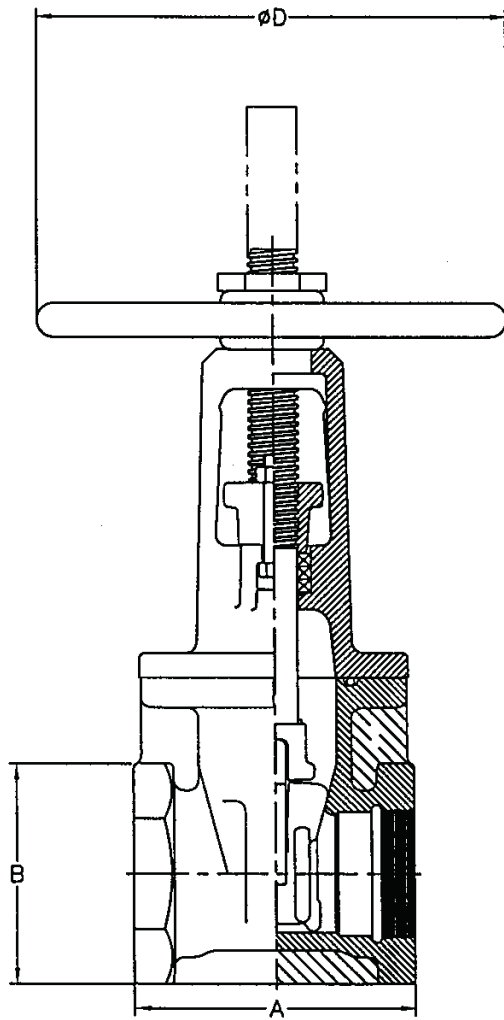

VALVE SIZE	A	B	D	E	F	WEIGHT*
2	5 1/4	4 1/8	7 1/4	10	12	N/A
2 1/2	7	5 3/16	7 1/4	13 7/8	16 3/8	40
3	7 1/2	5 3/16	10	15 5/8	18 7/8	50