

	PATT OR DIE No.	FINISH	UNLESS OTHERWISE SPECIFIED DECIMAL DIM'S IN 2 PLACES + or - .02 DIM'S IN 3 PLACES + or - .01 FRACTION DIM'S UNDER 6" + or - DIM'S OVER 6" + or -
LETTER CHANGE	MATERIAL	WEIGHT	
REF. Nos.			

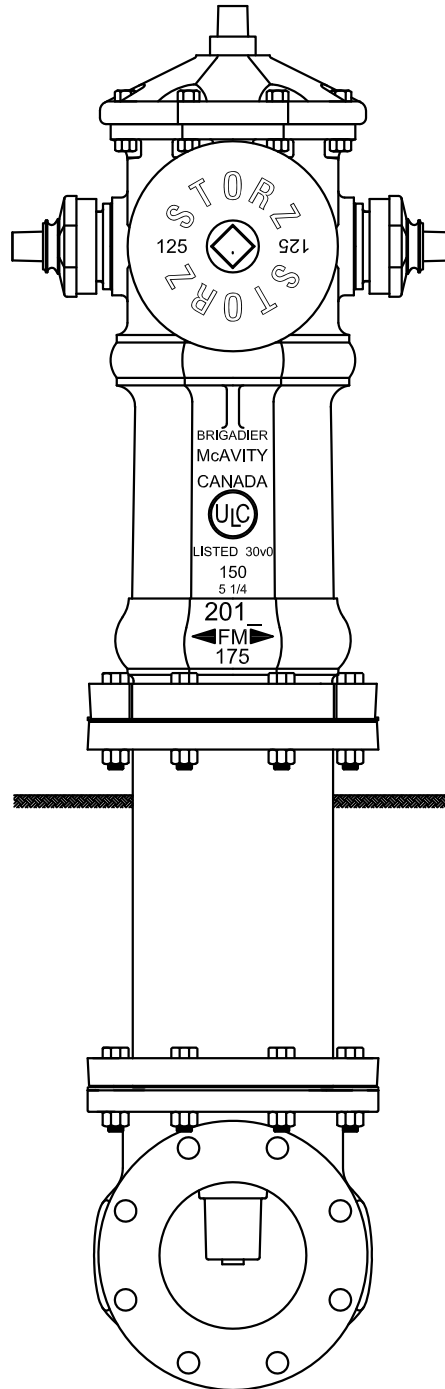

DRAWN <i>L.G. McKAY</i>	CHECKED	EXAMINED	NOTED	APPROVED
----------------------------	---------	----------	-------	----------

M67B HERITAGE 2 HOSE 5" (125mm)
STORZ PUMPER WITH 6" FLANGED
ELBOW

CLOW CANADA

M67B - 020

SCALE NOT TO SCALE DATE SEPT. / 2010